



Technical Publication

Optima XR646 HD Pre-Installation

Direction 5643972-1EN
Revision 11
US English

LEGAL NOTES

TRADEMARKS

All other products and their name brands are trademarks of their respective holders.

COPYRIGHTS

All Material, Copyright © 2018-2024 by GE HealthCare. All rights reserved. The material presented and contained herein may not be reproduced in any form or manner, without the written permission of GE HealthCare.

Contact Information

Optima XR646 HD

Optima XR646 HD Systems can be sold by the below names and be manufactured by the below manufactures.

Model Name	Optima XR646 HD	
Manufacturer (*)	GE Hualun Medical Systems Co., Ltd.	
Manufacturer address	No. 1, Yong Chang North Road, Beijing Economic Technological Development Zone, 100176 Beijing P.R. China	
Manufacturing site	GE Hualun Medical Systems Co., Ltd.	GE MEDICAL SYSTEMS, LLC
Manufacturing site address	No. 1, Yong Chang North Road, Beijing Economic Technological Development Zone, 100176 Beijing P.R. China	3000 North Grandview Blvd WAUKESHA, WI 53188 UNITED STATES

Language Policy

DOC0371395 - Global Language Procedure

PARALAJMËR- IM (SQ-AL)	<p>Ky manual është i disponueshëm në disa gjuhë.</p> <ul style="list-style-type: none"> Nëse një ofruer shërbimi klientësh kërkon një gjuhë të ndryshme nga ato që mundësohen në Portalin e dokumentacionit të klientit, është përgjegjësia e klientit që të ofrojë shërbime përkthimi. Mos u përpiqni të kryeni shërbime në pajisje, pa lexuar dhe kuptuar paraprakisht manualin e shërbimit. Mosrespektimi i këtij paralajmërimi mund të çojë në lëndim të ofruerit të shërbimit, operatorit ose pacientit si pasojë e goditjes elektrike, mekanike ose një rreziku tjetër.
تحذير (AR-SA)	<p>هذا الدليل متوفر بعدة لغات</p> <ul style="list-style-type: none"> إذا كان مقدم الخدمة التابع للعميل يطلب لغة غير تلك المتوفرة في بوابة توثيق العميل، فإنه يقع على عاتق العميل مسؤولية تقديم خدمات الترجمة لا تحاول صيانة الجهاز ما لم تتم استشارة دليل الخدمة هذا وفهمه قد يؤدي عدم مراعاة هذا التحذير إلى إصابة مقدم الخدمة أو المشغل أو المريض من جراء الصدمات الكهربائية أو المخاطر الميكانيكية أو غيرها من المخاطر

ПРЕДУПРЕЖ ДЕНИЕ (BG)	<p>Това ръководство е налично на няколко езика.</p> <ul style="list-style-type: none"> Ако доставчикът на услуги на даден клиент изисква език, който е различен от осигурените в портала с документация за клиенти, отговорност на клиента е да предостави преводачески услуги. Не се опитвайте да обслужвате оборудването, освен ако не сте се консултирали с това сервизно ръководство и сте го разбрали. Несъблюдаването на това предупреждение може да доведе до нараняване на предоставящия услугите, оператора или пациента вследствие на токов удар, механична или други опасности.
警告 (ZH-CN)	<p>本手册有多种语言版本。</p> <ul style="list-style-type: none"> 如果客户的服务提供商要求使用 Customer Documentation Portal (客户文档门户) 未提供的其他语言, 则客户有责任提供相应的翻译服务。 请勿尝试检修设备, 除非已明确参考并理解本检修手册。 不遵循此警告可能会导致检修服务提供者、操作员或患者受到触电、机械或其他危害的损伤。
警告 (ZH-HK)	<p>本手冊備有多個語言版本。</p> <ul style="list-style-type: none"> 若客戶的服務提供者所需語言版本不在 Customer Documentation Portal (客戶文件入口網站) 所列語言之中, 客戶需自行負責提供翻譯服務。 除非已查閱並理解本檢修手冊, 否則, 請勿嘗試檢修設備。 不遵循此警告可能會導致服務提供者、操作員或患者因為觸電、機械或其他危險而受傷。
警告 (ZH-TW)	<p>本手冊備有多個語言版本。</p> <ul style="list-style-type: none"> 若客戶的服務提供者所需語言版本不在 Customer Documentation Portal (客戶文件入口網站) 所列語言之中, 客戶需自行負責提供翻譯服務。 除非已查閱並理解本檢修手冊, 否則, 請勿嘗試檢修設備。 不遵循此警告可能會導致服務提供者、操作員或患者因為觸電、機械或其他危險而受傷。
UPOZORENJE (HR)	<p>Ovaj je priručnik dostupan na nekoliko jezika.</p> <ul style="list-style-type: none"> Ako serviser klijenta zahtijeva jezik koji nije jedan od jezika dostupnih na portalu s korisničkom dokumentacijom (Customer Documentation Portal), odgovornost je klijenta pružiti uslugu prevođenja. Nemojte pokušavati servisirati opremu ako niste proučili i razumjeli ovaj servisni priručnik. Nepoštovanje ovog upozorenja može izazvati ozljede servisera, rukovatelja ili pacijenta kao posljedicu strujnog udara, mehaničkih ili drugih opasnosti.
VÝSTRAHA (CS)	<p>Tato příručka je k dispozici v několika jazycích.</p> <ul style="list-style-type: none"> Pokud zákazníkům poskytovatel služeb vyžaduje jiný jazyk než jazyky, které jsou k dispozici na portálu s uživatelskou dokumentací, je odpovědností zákazníka poskytnout překladatelské služby. Nepokoušejte se provádět servis zařízení, aniž byste prostudovali tuto servisní příručku a porozuměli jí. Nedodržení tohoto varování může vést ke zranění poskytovatele služeb, obsluhy nebo pacienta, způsobenému úrazem elektrickým proudem či mechanickým nebo jiným nebezpečím.
ADVARSEL (DA)	<p>Denne vejledning fås på flere sprog.</p> <ul style="list-style-type: none"> Hvis en kundes tjenesteudbyder kræver et andet sprog end dem, der er til rådighed i Kundedokumentationsportalen, er det kundens ansvar at levere oversættelsestjenester. Undgå at forsøge at udføre service på udstyret, medmindre du har læst og forstået denne servicevejledning. Hvis du undlader at overholde denne advarsel, kan det føre til skader på servicemedarbejderen, operatøren eller patienten på grund af elektrisk stød, mekaniske eller andre farer.

WAARSCHUWING (NL)	<p>Deze handleiding is in verschillende talen beschikbaar.</p> <ul style="list-style-type: none"> Als de serviceprovider van een klant een andere taal vereist dan de talen die beschikbaar worden gesteld in het Customer Documentation Portal (Klantdocumentatieportaal), is het de verantwoordelijkheid van de klant om vertaalservices te leveren. Probeer geen service op de apparatuur uit te voeren zonder de servicehandleiding te hebben gelezen en begrepen. Het negeren van deze waarschuwing kan leiden tot letsel bij de serviceprovider, de operator of de patiënt door elektrische schokken, mechanische of andere gevaren.
WARNING (EN)	<p>This manual is available in several languages.</p> <ul style="list-style-type: none"> If a customer's service provider requires a language other than those provided in the Customer Documentation Portal, it is the customer's responsibility to provide translation services. Do not attempt to service the equipment unless this service manual has been consulted and is understood. Failure to heed this warning may result in injury to the service provider, operator or patient from electric shock, mechanical or other hazards.
HOIATUS (ET)	<p>Käesolev juhend on saadaval mitmes keeles.</p> <ul style="list-style-type: none"> Kui kliendi teenusepakkuja vajab juhendit mõnes muus keeles, mida pole kliendidokumentatsiooni portaalis, on kliendi kohustuseks tõlketeenuste osutamine. Ärge hakake seda seadet hooldama enne, kui olete käesolevat hooldusjuhendit lugenud ja selle sisu mõistnud. Selle hoiatuse eiramine võib põhjustada hooldusteenuse pakkujale, operaatorile või patsiendile elektrilöögist, mehhaanilistest või muudest ohtudest tulenevaid vigastusi.
VAROITUS (FI)	<p>Tämä opas on saatavilla useilla kielillä.</p> <ul style="list-style-type: none"> Jos asiakkaan palveluntarjoaja edellyttää muita kuin asiakkaan asiakirjaportaalissa saatavilla olevia kieliä, käännöspalveluiden tarjoaminen on asiakkaan vastuulla. Lue huolto-opas huolellisesti ennen laitteen huoltotoimenpiteiden suorittamista. Tämän varoituksen huomiotta jättäminen voi johtaa huollon suorittajan, laitteen käyttäjän tai potilaan loukkaantumiseen sähköiskun, mekaanisen vaaran tai muun vaaran vuoksi.
ATTENTION (FR)	<p>Ce manuel est disponible en plusieurs langues.</p> <ul style="list-style-type: none"> Si le prestataire de services d'un client nécessite que le manuel soit rédigé dans une autre langue que celles fournies sur le Portail de Documentation Client, il incombe au client de le faire traduire. Ne pas essayer d'assurer la maintenance de l'équipement sans avoir au préalable consulté et compris les informations contenues dans ce manuel. Le non-respect de cet avertissement peut entraîner chez le technicien, l'opérateur ou le patient des blessures dues à des dangers électriques, mécaniques ou autres.
WARNUNG (DE)	<p>Dieses Handbuch ist in mehreren Sprachen erhältlich.</p> <ul style="list-style-type: none"> Wenn ein Dienstleister des Kunden dieses in einer anderen Sprache als der im Kundendokumentationsportal verfügbaren benötigt, liegt es in der Verantwortung des Kunden, Übersetzungsdienstleistungen zu erbringen. Wartungsarbeiten am Gerät dürfen nur durchgeführt werden, nachdem dieses Handbuch gelesen und verstanden wurde. Andernfalls besteht Verletzungsgefahr für den Dienstleister, Bediener oder Patienten durch Stromschlag, mechanische Gefahren oder andere Gefahren.

ΠΡΟΕΙΔΟΠΟΙΗΣΗ (EL)	<p>Αυτό το εγχειρίδιο διατίθεται σε διάφορες γλώσσες.</p> <ul style="list-style-type: none"> Εάν ο πάροχος υπηρεσιών συντήρησης ενός πελάτη χρειάζεται διαφορετική γλώσσα από αυτές που διατίθενται στο Customer Documentation Portal (Πύλη τεκμηριώσεων πελάτη), ο πελάτης είναι υπεύθυνος για την παροχή υπηρεσιών μετάφρασης. Μην επιχειρήσετε να εκτελέσετε συντήρηση του εξοπλισμού, εάν δεν έχετε διαβάσει και κατανοήσει το παρόν εγχειρίδιο συντήρησης. Εάν δεν τηρήσετε αυτήν την προειδοποίηση, μπορεί να προκληθεί τραυματισμός του παρόχου υπηρεσιών συντήρησης, του χειριστή ή του ασθενούς λόγω ηλεκτροπληξίας, μηχανικής βλάβης ή άλλου κινδύνου.
אזהרה (HE)	<p>מדריך זה זמין במספר שפות</p> <ul style="list-style-type: none"> אם-Customer Documentation Portal (פורטל תיעוד) פקד שירות של לקוח זקוק לשפה שאינה מסופקת ב (ללקוחות), באחריות הלקוח לספק את שירותי התרגום, (ללקוחות) אסור לנסות להעניק שירות לציוד לפני עיון במדריך שירות זה והבנת התוכן שלו פעולה שלא בהתאם לאזהרה זו עלולה לגרום לפגיעה של ספק השירות, המפעיל או המטופל כתוצאה מהתחמלות, סיכונים מכניים או סיכונים אחרים
FIGYELMEZTETÉS (HU)	<p>Ez a kézikönyv több nyelven is rendelkezésre áll.</p> <ul style="list-style-type: none"> Ha az ügyfél szervizszolgáltatója azoktól eltérő nyelvű kézikönyvet szeretne, mint amelyeket az Ügyféldokumentációs portálon biztosítunk, akkor az ügyfél feladata, hogy gondoskodjon a megfelelő fordításról. Ne próbálkozzon a berendezés szervizelésével anélkül, hogy a jelen szervizkézikönyvet elolvasta és megértette volna. Ennek a figyelmeztetésnek a figyelmen kívül hagyása áramütés, mechanikai vagy egyéb veszélyek következtében a szervizszolgáltató, a kezelő vagy a páciens sérülését okozhatja.
AÐVÖRUN (IS)	<p>Þessi handbók er fáanleg á mörgum tungumálum.</p> <ul style="list-style-type: none"> Ef þjónustuaðili viðskiptavinar þarfnast annars tungumáls en þessara tungumála er það á ábyrgð viðskiptavinarins að veita þýðingarþjónustu. EKKI reyna að þjónusta búnaðinn fyrr en búið er að lesa og skilja þessa þjónustuhandbók. Sé ekki farið eftir þessari viðvörðun getur það valdið meiðslum á þjónustuaðila, notanda eða sjúklingi af völdum raflosts, vélrænna áverka eða annarar hættu.
PERINGATAN (IN)	<p>Manual ini tersedia dalam beberapa bahasa.</p> <ul style="list-style-type: none"> Jika penyedia layanan pelanggan membutuhkan bahasa selain dari yang disediakan dalam Portal Dokumentasi Pelanggan, merupakan tanggung jawab pelanggan untuk menyediakan layanan penerjemahan. Jangan berupaya untuk melakukan servis pada peralatan sebelum menyimak manual servis dan memahami isinya. Jika peringatan ini tidak ditaati, ini dapat menyebabkan cedera penyedia layanan, operator, atau pasien, akibat sengatan listrik, bahaya mekanis, atau bahaya lainnya.
AVVERTENZA (IT)	<p>Il presente manuale è disponibile in varie lingue.</p> <ul style="list-style-type: none"> Qualora un fornitore di servizi del cliente richieda una lingua diversa da quelle fornite nel Portale con la documentazione per il cliente, sarà responsabilità del cliente fornire il servizio di traduzione corrispondente. Non tentare di riparare l'apparecchiatura se non si è prima consultato e compreso il presente manuale di servizio. Il mancato rispetto di questa avvertenza può provocare lesioni per il fornitore dei servizi, per l'operatore o per il paziente, a causa di scosse elettriche, meccaniche o altri pericoli.

警告 (JA)	<p>本マニュアルは多言語で提供されています。</p> <ul style="list-style-type: none"> お客様のサービスプロバイダが、お客様ドキュメントポータルページで使用されていない言語を必要とする場合は、お客様の責任で翻訳サービスを提供してください。 機器の保守を行う場合は、必ず本サービスマニュアルを読み理解した上で行ってください。 この警告に従わない場合は、サービスプロバイダー、オペレータ、または患者が、感電、機械的異常、またはその他の有害要因によって負傷する恐れがあります。
경고 (KO)	<p>이 설명서는 여러 언어로 제공됩니다.</p> <ul style="list-style-type: none"> 고객의 서비스 제공자가 고객 문서 포털에 제공된 언어가 아닌 다른 언어를 요구하는 경우 번역 서비스를 제공하는 것은 고객의 책임입니다. 이 서비스 설명서를 참고했고 이해하지 않는 한은 해당 장비를 수리하려고 시도하지 마십시오. 이 경고를 지키지 않으면 감전, 기계상의 위험 또는 다른 위험으로부터 서비스 제공자, 사용자 또는 환자가 다칠 수 있습니다.
BRĪDINĀJUMS (LV)	<p>Šī rokasgrāmata ir pieejama vairākās valodās.</p> <ul style="list-style-type: none"> Ja klientu apkalpošanas speciālistam ir nepieciešama cita valoda, kas nav piedāvāta klientu dokumentācijas portālā, klienta pienākums ir nodrošināt tulkošanas pakalpojumus. Nemēģiniet veikt aprīkojuma apkopi, kamēr nav izlasīta un izprasta apkopes rokasgrāmata. Ja šis brīdinājums netiek ņemts vērā, pakalpojumu sniedzējs, operators vai pacients var tikt savainots elektriskās strāvas trieciena, mehāniskas vai citas bīstamības rezultātā.
ĮSPĖJIMAS (LT)	<p>Šis vadovas yra išverstas į keletą kalbų.</p> <ul style="list-style-type: none"> Jei kliento paslaugų teikėjui reikalingas vertimas į kitą kalbą, kurios nėra kliento dokumentacijos portale, už vertimo paslaugų suteikimą atsako klientas. Neatlikite įrangos techninės priežiūros, kol neperžiūrėjote ir neišsiaiškinote šio techninės priežiūros vadovo. Nepaisant šio įspėjimo dėl elektros smūgio, mechaninio arba kitokio pavojaus gali būti sužalotas paslaugų teikėjas, operatorius arba pacientas.
TWISSIJA (MT)	<p>Dan il-manwal huwa disponibbli f'diversi lingwi.</p> <ul style="list-style-type: none"> Jekk fornitur tas-servizz ta' klient ikun jeħtieġ lingwa għajr dawk ipprovduti fil-Portal tad-Dokumentazzjoni tal-Klijent, hija r-responsabbiltà tal-klijent li jipprovidi servizzi ta' traduzzjoni. Tippruvax tagħmel service fuq it-tagħmir sakemm ma jkunx għe kkonsultat u mifhum dan il-manwal għas-service. Jekk wieħed jonqos milli josserva din it-twissija, dan jista' jwassal f'korrimment lill-fornitur tas-servizz, lill-operatur jew lill-pazjent minn xokk elettriku, mekkaniku, jew perikli oħra.
ADVARSEL (NO)	<p>Denne håndboken er tilgjengelig på flere språk.</p> <ul style="list-style-type: none"> Hvis en kundes tjenesteleverandør krever et annet språk enn de som finnes i dokumentasjonsportalen for kunder, er det kundens ansvar å levere en oversettelsestjeneste. Ikke prøv å utfør service på utstyret med mindre man har konsultert og forstått servicehåndboken. Om denne advarselen ikke følges kan det føre til skade på tjenesteleverandør, operatør eller pasient fra elektrisk støt, mekanisk eller annen fare.
OSTRZEŻENIE (PL)	<p>Niniejszy podręcznik jest dostępny w kilku językach.</p> <ul style="list-style-type: none"> Jeżeli serwisant klienta wymaga języka, który nie został udostępniony w portalu dokumentacji klienta, obowiązkiem klienta jest zapewnienie usług tłumaczeniowych. Nie podejmować prób serwisowania urządzenia bez uprzedniego zapoznania się z niniejszym podręcznikiem serwisowym i zrozumienia jego treści. Nieprzestrzeganie tego ostrzeżenia może spowodować obrażenia u serwisanta, operatora lub pacjenta, spowodowane porażeniem prądem, zagrożeniami mechanicznymi lub innymi.

<p>ATENÇÃO (PT-BR)</p>	<p>Este manual está disponível em vários idiomas.</p> <ul style="list-style-type: none"> • Se o prestador de serviços de um cliente necessitar de um idioma diferente dos fornecidos no Portal da Documentação do Cliente, o fornecimento dos serviços de tradução é de responsabilidade do cliente. • Não tente realizar manutenção do equipamento a menos que o manual de serviço tenha sido consultado e seja entendido. • O não cumprimento deste aviso resultará em lesões ao provedor de serviço, operador ou paciente de choque elétrico, mecânico ou outros riscos.
<p>ATENÇÃO (PT-PT)</p>	<p>Este manual está disponível em vários idiomas.</p> <ul style="list-style-type: none"> • Se o fornecedor de serviços de um cliente necessitar de um idioma diferente dos fornecidos no Portal de Documentação do Cliente, é da responsabilidade do cliente assegurar os serviços de tradução. • Não experimente reparar o equipamento sem primeiro consultar, e compreender, o presente manual de assistência. • O incumprimento deste aviso pode resultar em ferimentos para o técnico de reparação, o operador ou o paciente decorrentes de perigos de eletrocussão, mecânicos ou outros.
<p>ATENȚIE (RO)</p>	<p>Acest manual este disponibil în mai multe limbi.</p> <ul style="list-style-type: none"> • Dacă furnizorul de servicii al unui client necesită o limbă diferită de cele furnizate în Customer Documentation Portal (Portalul cu documentație pentru clienți), este responsabilitatea clientului să furnizeze servicii de traducere. • Nu încercați să efectuați întreținerea echipamentului decât dacă ați consultat și ați înțeles acest manual de service. • Nerespectarea acestei avertizări poate duce la rănirea furnizorului de servicii, a operatorului sau a pacientului din cauza șocurilor electrice, mecanice sau a altor pericole.
<p>ПРЕДУПРЕЖДЕНИЕ (RU)</p>	<p>Это руководство доступно на нескольких языках.</p> <ul style="list-style-type: none"> • Если поставщику услуг заказчика требуется языковая версия, отличная от предложенных на портале документации для заказчиков, перевод руководства на необходимый язык осуществляется стороной заказчика. • Не начинайте эксплуатацию оборудования без предварительного надлежащего ознакомления с этим руководством. • Если вы проигнорируете это предупреждение, поставщик услуг, оператор или пациент могут получить механические травмы, травмы вследствие поражения электрическим током или другие увечья.
<p>UPOZORENJE (SR)</p>	<p>Ovaj priručnik je dostupan na nekoliko jezika.</p> <ul style="list-style-type: none"> • Ako korisnikov serviser zahteva neki drugi jezik osim onih koji su dostupni na portalu sa korisničkom dokumentacijom (Customer Documentation Portal), klijent mora da obezbedi prevod. • Nemojte pokušavati da servisirate opremu ako niste proučili i razumeli ovaj priručnik za servisiranje. • Nepoštovanje ovog upozorenja može da izazove povrede servisera, operatera ili pacijenta kao posledicu strujnog udara, mehaničkih ili drugih opasnosti.
<p>UPOZORNENIE (SK)</p>	<p>Táto príručka je k dispozícii v niekoľkých jazykoch.</p> <ul style="list-style-type: none"> • Ak poskytovateľ služieb daného zákazníka požaduje jazyk odlišný od jazykov dostupných na portáli s dokumentáciou pre zákazníkov, za prekladateľské služby zodpovedá zákazník. • Nepokúšajte sa vykonávať servis na zariadení, pokiaľ ste si neprečítali a nepochopili pokyny v servisnej príručke. • Nedodržanie tohto varovania môže byť príčinou úrazu poskytovateľa servisu, obsluhy alebo pacienta v dôsledku zásahu elektrickým prúdom alebo v dôsledku mechanických alebo iných nebezpečenstiev.

OPOZORILO (SL)	<p>Ta priročnik je na voljo v več jezikih.</p> <ul style="list-style-type: none"> • Če ponudnik storitev stranke potrebuje priročnik v jeziku, ki ni na voljo na portalu z dokumentacijo stranke, mora stranka zagotoviti prevod. • Opreme ne poskušajte servisirati, če niste prebrali in razumeli tega servisnega priročnika. • V primeru neupoštevanja tega opozorila lahko pride do telesnih poškodb ponudnika storitev, upravljavca ali pacienta zaradi električnega udara, mehanskih ali drugih nevarnosti.
ADVERTENCIA (ES)	<p>Este manual se encuentra disponible en varios idiomas.</p> <ul style="list-style-type: none"> • Si el proveedor de servicios de un cliente requiere un idioma distinto de los proporcionados en el Customer Documentation Portal (Portal de documentación para clientes), es responsabilidad del cliente proporcionar los servicios de traducción. • No intente realizar el mantenimiento del sistema a menos que haya consultado y comprendido este manual de servicio. • El incumplimiento de esta advertencia puede causar lesiones al suministrador de servicios, el operador o el paciente debido a descarga eléctrica, mecánica u otros riesgos.
VARNING (SV)	<p>Denna manual är tillgänglig på flera språk.</p> <ul style="list-style-type: none"> • Om en kunds tjänsteleverantör behöver ett annat språk än de som tillgängliggjorts på portalen för kunddokumentation är det kundens ansvar att erbjuda översättningstjänster. • Försök inte att reparera utrustningen utan att först rådfråga och förstå denna servicehandbok. • Om denna varning inte beaktas kan det leda till skada för tjänsteleverantör, operatör eller patient genom elektrisk stöt, mekaniska eller andra faror.
DİKKAT (TR)	<p>Bu kılavuz birden fazla dilde sunulmaktadır.</p> <ul style="list-style-type: none"> • Bir müşterinin servis sağlayıcısı Müşteri Belgeleri Portalı'nda sağlananlardan farklı bir dil talep ederse çeviri hizmeti sağlamak müşterinin sorumluluğundadır. • Bu servis kılavuzuna başvurmadan ve içeriğini anlamadan ekipman üzerinde servis işlemi yapmayı denemeyin. • Bu uyarıya uyulmaması; elektrik çarpması, mekanik tehlikeler veya başka tehlikelerden ötürü servis sağlayıcı, operatör veya hastanın yaralanmasıyla sonuçlanabilir.
ПОПЕРЕДЖЕННЯ (UK)	<p>Цей посібник доступний кількома мовами.</p> <ul style="list-style-type: none"> • Якщо постачальник послуг замовника використовує мову, яку не вказано на порталі з документацією для замовників, послуги з перекладу має забезпечити замовник. • Не починайте роботу з обладнанням без попереднього належного ознайомлення з посібником із використання. • Якщо ви проігноруйте це попередження, постачальник послуг, оператор або пацієнт можуть зазнати механічних травм, ураження електричним струмом або інших тілесних ушкоджень.
CẢNH BÁO (VI)	<p>Tài liệu hướng dẫn này có sẵn ở một số ngôn ngữ.</p> <ul style="list-style-type: none"> • Nếu nhà cung cấp dịch vụ của khách hàng yêu cầu ngôn ngữ khác với ngôn ngữ được cung cấp trong Cổng Thông Tin Tài Liệu Khách Hàng, khách hàng có trách nhiệm cung cấp dịch vụ dịch thuật. • Không cố bảo dưỡng thiết bị trừ khi đã tham khảo và hiểu rõ hướng dẫn sử dụng này. • Việc không chú ý đến cảnh báo này có thể dẫn đến thương tích cho nhà cung cấp dịch vụ, người vận hành hoặc bệnh nhân do điện giật, nguy hiểm cơ học hoặc các mối nguy hiểm khác.

Revision History

Rev	Date	Reason For Change
1	May 22, 2018	First release

Rev	Date	Reason For Change
2	Sep 29, 2018	<p>Update:</p> <ul style="list-style-type: none"> add Note for anchors installation statement in Chapter 2 Section 1.2.2.1 update Wall Stand Dimensions (0 and 90 degrees) figure in Chapter 2 Section 2.6 update typing Dongle to AP of room layout in Chapter 2 Section 3.3 add Global G3 Std in Table Only of Table 2-7 Optima XR646 HD System Configuration in Chapter 2 Section3.3
3	Mar 18, 2019	<p>Update</p> <ol style="list-style-type: none"> 1. Chapter 1 <ul style="list-style-type: none"> Add Section 1.3 Site Readiness Checklist Add Section 3.3.2 Manual WS is delivered on a fixture <p>Updated:</p> <ul style="list-style-type: none"> Section 3.1 Door size requirement Section 3.4 Shipping and Transit Dimensions and Weights Deleted Section4.0 (due to repeat content with HVAC) 2. Chapter 2 Updated: <ul style="list-style-type: none"> Section 1.1 System Components Section 1.2.1 Acoustic Output Illustration 2-7 and Illustration 2-8 Section 1.2.3 Ceiling Requirement Section 2.1 Dimensions Table 2-7 Optima XR646 HD System Configuration Section 3.0 Room Layout 3. Section 4.0 Seismic <ul style="list-style-type: none"> 4.3 Center of Gravity Information (Based on DOC2281273 Rev2) 4. Add Chapter 2 Section 1.2.2.3 PC floor mounting requirement for Seismic Region 5. Add Chapter 2 Section 1.2.3.1 12m Rail mounting requirement. 6. Section 2.2 Flash Pad HD Detector overview 7. Add Section 2.6.2 Manual WS 8. Add Chapter 2 Section 2.7 Stretcher Tables 9. Chapter 5 - Electrical <ul style="list-style-type: none"> Updated Illustration 5-5a: Global G3 Table Cable Entrance Updated Illustration 5-5b: Global G3 Std Table Cable Entrance 10. Chapter 7 Updated : <ul style="list-style-type: none"> 2.3 Global G3 Table Standard Length MIS Cable 5777374 2.4 Global G3 Table Long Length MIS Cables 5777375 2.5 Standard WS Length Version 5777377 2.6 Ext WS Length Version 5777376 2.8 TIB 11. Update System MIS Chart to rev3 12. Update Section 4.0 System Architecture

Rev	Date	Reason For Change
4	Apr 3, 2020	Update: 1. Chapter 2 Section 3.3 added row to Table 2-7 Optima XR646 HD System Configuration 2. Chapter 6 Added Section 3.0 InSite Configuration 3. Chapter 7 Section 3.0 Updated the MIS Chart Removed references to 8770000-24
5	Aug 17, 2020	Update: Add VCP Cabinet related information and table manufactured in Monterrey.

Rev	Date	Reason For Change
6	Nov. 23, 2020	<ol style="list-style-type: none"> 1. High definition VCP cabinet picture replaced original one in Figure 1-3 in 3.3.4 section of Chapter 1 2. Update Table 2-13 Table and Standard/Extended Wall Stand at Head with 3M Bridge in 3.3 Configurations and option of Chapter 2 3. Add new 1.2.2.1 Floor Levelness Specifications into 1.2 Floor Requirements section of Chapter 2 4. Update Table 2-3 Recommended, Minimum and Maximum Room Heights in 1.2.3.1 Section of Chapter 2 5. Change Figure 2-8 Specifications for a Typical 4064mm (13'- 4") Stationary Rail Mounting Interface (Both Rails Ceiling Mounted) with 2M Bridge in 1.2.3.1 Section of Chapter 2 6. Change Figure 2-9 Specifications for a Typical 4064mm (13'- 4") Stationary Rail Mounting Interface (Both Rails Ceiling Mounted) with 3M Bridge in 1.2.3.1 Section of Chapter 2 7. Change Figure 2-10 Suggested UNISTRUT Structure for OTS Suspension with 2 m Bridgel in 1.2.3.1 Section of Chapter 2 8. Change Figure 2-11 Suggested UNISTRUT Structure for OTS Suspension with 3 m Bridgel in 1.2.3.1 Section of Chapter 2 9. Change Figure 2-12 Stationary Rail Mounting Locations and Clearances with 2M Bridge and cable chain in 1.2.3.1 Section of Chapter 2 10. Change Figure 2-13 Stationary Rail Mounting Locations and Clearances with 3M Bridge and cable chain in 1.2.3.1 Section of Chapter 2 11. Add Figure 2-14 and 2-15 in 1.2.3.1 Section of Chapter 2 12. Change and add picture in 1.2.3.2 Cable Chain Support Location of Chapter 2 13. Change Figure 2-35 OTS Suspension Focal Spot Travel Range - 2M Bridge in 2.6 Section of Chapter 2 14. Change Figure 2-36 OTS Suspension Focal Spot Travel Range - 2M Bridge in 2.6 Section of Chapter 2 15. Add "notice" under 3.0 Room Layout of Chapter 2 16. Update number in Table 2-9 Standard/Extended Arm Wall Stand only, at Foot with 2M/3M Bridge in 3.3 Section of Chapter 2 17. Update number in Table 2-10 Standard/Extended Arm Wall Stand only at Head with 2M/3M Bridge in 3.3 Section of Chapter 2 18. Update number in Table 2-11 Manual WS only on head/ foot side with 2m or 3m bridge in 3.3 Section of Chapter 2 19. Change Figure 2-56 Table and Standard/Extended Wall Stand at Foot with 3M Bridge in 3.3 Section of Chapter 2 20. Update numbers, add item 6 & 7 content and delete item 10 content in Table 2-12 Table and Standard/Extended Wall Stand at Foot with 3M Bridge in 3.3 Section of Chapter 2 21. Change Figure 2-57 Table and Manual Wall Stand at Foot with 3M Bridge in 3.3 Section of Chapter 2 22. Update Table 2-16 item 2 Limit Dimension in 3.3 Section of Chapter 2 23. Update Figure 2-76 and add Figure 2-77 in 4.3.12 OTS With Bridge Section of Chapter 2 24. Update item 2,6,7,8,10 Limit Dimension in Table 2-14 in 3.3 section of Chapter 2 25. Update Figure 2-59 Table and Manual Wall Stand at Head with 3M Bridge in 3.3 Section of Chapter 2 26. Update Table 2-16 Summary Result in 3.3.3 section of Chapter 22

Rev	Date	Reason For Change
		<p>27. Update item 2, 6,7 Limit Dimension in Table 2-13 Table and Manual Wall Stand at Foot with 3M Bridge in 3.3 Section of Chapter 2</p> <p>28. Update Table 2-15 item 2, 6,7 Limit Dimension in 3.3 Section of Chapter 2</p>
7	Aug 12, 2022	<ol style="list-style-type: none"> 1. Chapter 2: <ul style="list-style-type: none"> 2.1.2.3.1: update Table 2-3; update the title of Figure 2-5; add a picture and its description in Figure 2-8, 2-9 2.1.2.3.2: update the figure 2.1.2.5: add new contents; delete a paragraph 2.2.1: add VCP cable information in table 2-6 2.2.11: update PC and VCP Cabinet information in table 2-8 2.3.3: update Table 2-14, 2-15, 2-16, 2-17; delete the section Advanced application needs 2.4.3.5: update HP workstation information 2. Chapter 5: <ul style="list-style-type: none"> 5.5.1: update the title 3. Chapter 6: <ul style="list-style-type: none"> 6.2.5: modify the AP IP 6.3: update contents 4. Chapter 7: <ul style="list-style-type: none"> 7.2: update Cable Information 7.3: update MIS Map
8	Nov 25, 2022	<ol style="list-style-type: none"> 1. Chapter 2: <ul style="list-style-type: none"> Section 2.1.1 System Components: update the content and the image Section 2.1.1.1 Optional Components: update the content and the image Section 2.1.2.2 Floor Requirements When Using Provided Typical Floor Anchors: add "Figure 2-4 Optimized anchor bolts" Section 2.4 Seismic: update the content
9	Mar 1, 2023	<ol style="list-style-type: none"> 1. Section 2.2.1 Dimensions: <ul style="list-style-type: none"> • Update 5143542, 5127305 to 5500972, 5500971 2. Section 2.3.1 Required Service Access Clearance <ul style="list-style-type: none"> • Add note for "The right side space for service can be moved to the left side also."
10	Apr 11, 2024	<ol style="list-style-type: none"> 1. Section 2.2.1 Dimensions: <ul style="list-style-type: none"> • Update the height of "Image Pasting Barrier with Footstool (option)" from 2070mm to 2097mm • Add another UPS (7000700-RL1T) dimension in "UPS (option)" 2. Section 2.2.10 UPS: <ul style="list-style-type: none"> • Add another UPS (7000700-RL1T) dimension image 3. Section 2.2.11 Weights, Floor/Ceiling Loading and Recommended Mounting Methods: <ul style="list-style-type: none"> • Add another UPS (7000700-RL1T) weight
11	Nov 15, 2024	<p>Chapter 2:</p> <ul style="list-style-type: none"> • On section 2.4.3.5 HP workstation: Added fig2-74.

Contents

1 General Requirements.....	23
1.1 Objectives and Overview Summary	23
1.1.1 Objective and Scope of This Manual	23
1.1.2 Summary	23
1.1.3 Site Readiness Checklist	23
1.2 Common Product Requirements.....	24
1.2.1 Dimensions and Layout	24
1.3 Delivery Requirements.....	25
1.3.1 Door Size Requirements	25
1.3.2 Minimum Elevator Depth Requirements.....	25
1.3.3 Shipping Fixtures and Carts.....	26
1.3.4 Shipping Dimensions and Weights.....	31
1.3.5 Preparing the Delivery Route	33
2 Equipment	34
2.1 System Components	34
2.1.1 System Components.....	34
2.1.1.1 Optional Components	35
2.1.2 Room Requirements	37
2.1.2.1 Acoustic Output	37
2.1.2.2 Floor Requirements	37
2.1.2.3 Ceiling Requirements	40
2.1.2.4 Wall Requirements.....	54
2.1.2.5 Room Light Requirements.....	58
2.1.2.6 Exam Room Size.....	59
2.2 System Component Dimensions and Weights.....	61
2.2.1 Dimensions.....	61
2.2.2 FlashPad HD Detector	63
2.2.3 Table	65
2.2.4 System Cabinet	68
2.2.5 VCP cabinet	69
2.2.6 Over-Head Tube Support (OTS).....	70
2.2.7 Wall Stands.....	72
2.2.7.1 Standard WS and Extended WS.....	72
2.2.7.2 Manual WS.....	76
2.2.8 Stretcher Tables	78
2.2.9 Image Pasting Barrier.....	79
2.2.10 UPS	80
2.2.11 Weights, Floor/Ceiling Loading and Recommended Mounting Methods.....	81
2.2.12 Longitudinal Rails	82
2.3 Room Layout	83
2.3.1 Required Service Access Clearance	83
2.3.2 Clinical Access	85
2.3.3 Configurations and option.....	85

- 2.3.3.1 Room Layout Analysis for Table & WS.....96
- 2.3.3.2 Summary Result.....96
- 2.3.3.3 Min size room template with Table & WS at Foot(3m bridge)97
- 2.3.3.4 Room Size Summary102
- 2.4 Seismic.....103
 - 2.4.1 Overview.....103
 - 2.4.2 Calculations.....103
 - 2.4.3 Center of gravity information104
 - 2.4.3.1 Global G3 table (GCTBL-C3/GCTBL-C33)104
 - 2.4.3.2 Global Standard Table (GCTBL-C5)105
 - 2.4.3.3 Detector bin 5765692.....107
 - 2.4.3.4 Tether Interface Box 5765910/5876669.....108
 - 2.4.3.5 HP workstation108
 - 2.4.3.6 AP assembly110
 - 2.4.3.7 Grid box111
 - 2.4.3.8 G3 wall stand GCWS-C3112
 - 2.4.3.9 G3 extended wall stand GCEWS-C3.....113
 - 2.4.3.10 Manual Wall stand GCMWS-C5114
 - 2.4.3.11 Cabinet GCC-C3.....115
 - 2.4.3.12 OTS with bridge.....116
- 3 Special construction 120**
 - 3.1 Radiation Protection120
- 4 HVAC..... 121**
 - 4.1 Environmental Requirements.....121
 - 4.1.1 Relative Humidity and Temperature121
 - 4.1.2 Altitude and Atmospheric Pressure122
 - 4.1.3 Non-operating Environment122
 - 4.1.3.1 Temperature.....122
 - 4.1.3.2 Humidity.....122
 - 4.1.3.3 Atmospheric Pressure.....122
 - 4.1.3.4 Altitude.....122
 - 4.1.4 Heat Output.....123
 - 4.1.5 EMC Requirement123
- 5 Electrical..... 124**
 - 5.1 System Facility Power and Grounds124
 - 5.1.1 Introduction124
 - 5.1.2 Power Quality124
 - 5.1.3 Electrical Grounds.....125
 - 5.1.3.1 System and Facility Grounds.....125
 - 5.1.3.2 Recommended Ground Wire Sizes.....125
 - 5.2 Electrical Requirements.....125
 - 5.2.1 Generator Electrical Requirements125
 - 5.2.2 System Wire Sizes & kVA Load Characteristics.....126
 - 5.2.2.1 JEDI Generator 3-Phase 50 kW System - Minimum Wire Size127
 - 5.2.2.2 kVA Load Characteristics 50KW127
 - 5.2.2.3 JEDI Generator 3-Phase 65 kW and System - Minimum Wire Size128

5.2.2.4	kVA Load Characteristics 65KW	128
5.2.2.5	JEDI Generator 3-Phase 80 kW and System - Minimum Wire Size	128
5.2.2.6	kVA Load Characteristics 80KW	129
5.2.3	Recommended Wall Circuit-Breaker Ratings.....	129
5.2.4	Wiring Electrical Power and Disconnects.....	129
5.2.4.1	Room Power Supply	130
5.2.4.2	Multiple Emergency OFF Switches.....	131
5.3	Routing Cables	132
5.3.1	General	132
5.3.1.1	Electrical Ducts (Recommended).....	132
5.3.1.2	Conduit.....	132
5.3.2	Power Distribution	132
5.4	Light Specification.....	132
5.5	Dimensioned Figures and Drawings.....	133
5.5.1	Wall Box (if applicable)	133
5.5.2	System Equipment Cable Entrance.....	134
5.5.3	Power and cables requirements for TIB.....	136
5.5.4	Power and cables requirements for Chargers BIN.....	137
6	Communications/Networking	138
6.1	Hospital Network.....	138
6.1.1	Broadband Network Connection	138
6.1.2	Phone Line(s) - Voice.....	138
6.1.3	Remote Services Broadband Pre-Installation Requirements for Europe	139
6.2	Networkflow Audit	139
6.2.1	What is the Networkflow Audit.....	140
6.2.2	Facility Information.....	140
6.2.3	Workflow Analysis.....	140
6.2.4	The Physical Network	141
6.2.5	System Parameters	141
6.2.6	Devices & Services Audit.....	144
6.2.7	Data Flow Analysis	145
6.2.8	What Will Happen Next?.....	146
6.3	Remote Connection Configuration.....	146
7	Cable Information	148
7.1	Cable Introduction	148
7.2	Cable Information	148
7.2.1	OTS.....	148
7.2.2	System MIS Cable-OTS.....	149
7.2.3	Table Standard Length MIS Cable 5777374.....	149
7.2.4	Table Long Length MIS Cables 5777375	149
7.2.5	Standard WS Length Version 5777377	150
7.2.6	Ext WS Length Version 5777376.....	150
7.2.7	TIB.....	151
7.2.8	Wireless AP	151

7.2.9 Control Room MIS Cable (without Wall Box)	152
7.2.10 Control Room MIS Cable (with Wall Box, only applied for IB).....	152
7.2.11 Computer.....	153
7.3 System Master Interconnect Schematic (MIS Map)	154
7.4 System Architecture	156

Preface

Standardized conventions for representing information is a uniform way of communicating information to a reader in a consistent manner. Conventions are used so that the reader can easily recognize the actions or decisions that must be made. There are a number of character and paragraph styles used in this publication to accomplish this task. Please become familiar with them before proceeding forward.

It is important that you read and understand hazard statements, and not just ignore them.

Safety & Hazard Information

Proper product safety labeling allows a person to safely use or service a product. The format and style for safety communications reflected in this publication represents the harmonization of IEC/ISO 3864 and ANSI Z535 standards.

Within this publication, different paragraph and character styles are used to indicate potential hazards. Paragraph prefixes, such as hazard, caution, danger and warning, are used to identify important safety information. Text (Hazard) styles are applied to the paragraph contents that are applicable to each specific safety statement.

Hazard Messages

Any action that will, or could potentially cause personal injury will be preceded by the safety alert symbol and an appropriate signal word. The safety alert symbol is the triangle with an exclamation mark within it. It is always used next to the signal word to indicate the severity of the hazard. Together, they are used to indicate a hazard exists.

Signal words describe the severity of possible human injuries that may be encountered. The alert symbol and signal word are placed immediately before any paragraph they affect. Safety information includes:

1. Signal Word - The seriousness level of the hazard.
2. Symbol or Pictorial - The consequence of interaction with the hazard.
3. Word Message:
 - 3.1. The nature of the hazard (i.e. the type of hazard).
 - 3.2. How to avoid the hazard.

The safety alert symbol is not used when an action can only cause equipment damage.

Text Format of Signal Words

DANGER: the most severe label, indicates a hazard with a high level of risk which, if not avoided, will result in death or serious injury.















WARNING: indicates a hazard with a medium level of risk which, if not avoided could result in death or serious injury.

CAUTION: indicates a hazard with a low level of risk which, if not avoided, could result in minor or moderate injury.

NOTICE: indicates information considered important, but not hazard-related (no risk of injury, only a risk to the equipment).

Symbols and Pictorials Used

The following Symbols and Pictorials may be used in this publication. These graphical icons (symbols) may be used to make you aware of specific types of hazards that could possibly cause harm.

NOTICE	CAUTION	WARNING	DANGER	
 keep_up	 magnetic	 biohazard	 compressgas	 ppe-hearing
 fragile	 impact	 corrosive	 heavyobject	 ppe-2people
 static_elec	 heat	 general	 laser	 ppe-respiratory
 keep_dry	 pinch	 radiation	 poisongas	 ppe-loto
 general	 explosive	 electrical	 flammable	 ppe-eye
 torque	 crush/mechanical	 tipping	 Read Manual	 ppe-gloves
 ce	 instuction	 poisonmatl	 entanglement	 instuction

Equipment Classifications

The following equipment classifications are applicable to the product:

- Equipment classification with respect to protection from electric shock: Class I
- Degree of protection from electric shock: Type B
- Degree of protection against ingress of liquids: Not classified
- Equipment not suitable for use in the presence of a flammable anesthetic mixture with air or with nitrous oxide
- Mode of operation: Continuous operation with intermittent loading

Publication Conventions



NOTE

Please view the latest version when using this manual.

General Paragraph and Character Styles

Prefixes are used to highlight important non-safety related information. Paragraph prefixes (such as Purpose, Example, Comment or Note) are used to identify important but non-safety related information. Text styles are also applied to text within each paragraph modified by the specific prefix.

EXAMPLES OF PREFIXES USED FOR GENERAL INFORMATION:

Purpose:

Introduces and provides meaning as to the information contained within the chapter, section or subsection (such as used at the beginning this chapter, for example).

NOTE

Conveys information that should be considered important to the reader.

Example:

Used to make the reader aware that the paragraph(s) that follow are examples of information possibly stated previously.

Comment:

Represents “additional” information that may or may not be relevant to your situation.

Page Layout



Publication Part Number and Revision Number

Paragraphs processed by **Alphanumeric** characters (e.g. numbers) contain information that must be followed in a **specific order**.

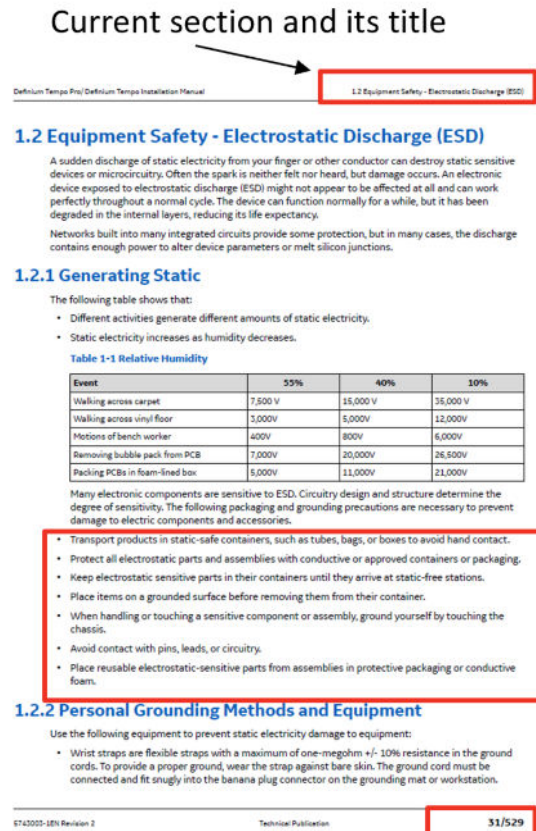

Current Page/Total Pages

Paragraphs processed by a **symbol** (e.g. bullets) contain information that has no **specific order**.

Headers and footers in this publication are designed to allow you to quickly identify your location. The document part number and revision number appear in every header on every page. Odd numbered page footers indicate the current chapter, its title and current page number. Even numbered page footers show the current section and its title, as well as the current page number.

Computer Screen Output/Input Text Character Styles

Within this publication, mono-spaced character styles (fonts) are used to indicate computer text that is either screen input or output. Mono-spaced fonts, such as courier, are used to indicate text direction. When you type at your keyboard, you are generating computer input. Occasionally you will see the math operator “greater-than” and “less-than” symbols used to indicate the start and finish of variable output. When reading text generated by the computer, you are reading it as computer generated output. In addition to direction, characters are italicized (e.g. *italics*) to indicate information specific to your system or site.

Format Name	Example of Use	Description	Notes on Use
Input - Fixed	ping darc	EXACT text to be entered via keyboard.	Spaces are significant.
Input - Variable	<ig#>	<i>User input (via keyboard) that varies according to the specific configuration of a given system.</i>	<ul style="list-style-type: none"> Typically, variable will be defined in the same or adjoining paragraph. Brackets (< and >) are NOT to be entered. They are simply a further indicator that the input is variable.
Screen Output - Fixed	ctuser@darc	This paragraph's font represents computer generated screen "fixed" output. Its output is fixed from the sense that it does not vary from application to application. It's the most commonly used style used to indicate filenames, paths and text that do not change from system to system. The character style used is a fixed width such as courier.	This example shows a command line prompt.
	usr/g/bin	Name of computer file directory.	
Screen Output - Variable	<hospital_name>	<i>This paragraph's font represents computer screen output that is "variable". It's used to represent output that varies from application to application or system to system.</i>	<ul style="list-style-type: none"> Variable may be defined in the same or adjoining paragraph. Brackets (< and >) are NOT to be displayed. They are simply a further indicator that the output is variable.
Keyboard	<Enter>	Physical key on computer keyboard.	
	<Ctrl+C>	Multiple keys on the computer keyboard.	The "+" indicates that both keys must be pressed at the same time.

Buttons, Switches and Keyboard Inputs (Hard & Soft Keys)

Different character styles are used to indicate actions requiring the reader to press either a hard or soft button, switch or key. Physical hardware, such as buttons and switches, are called hard keys because they are hard wired or mechanical in nature. A keyboard or on/off switch would be a hard key. Software or computer generated buttons are called soft keys because they are software generated. Software driven menu buttons are an example of such keys. Soft and hard keys are represented differently in this publication.

Example: Hard Keys

A power switch **ON/OFF** or a keyboard key like **ENTER** is indicated by applying a character style that uses both over and under-lined bold text. This is a hard key.

Example: Soft Keys

Whereas the computer **MENU** button that you would click with your mouse or touch with your hand uses over and under-lined regular text. This is a soft key.

1 General Requirements

1.1 Objectives and Overview Summary

1.1.1 Objective and Scope of This Manual

This document is intended as a guide and informational resource for planning and properly preparing a location for the installation of this system.

1.1.2 Summary

The purchaser is responsible for completion of “Pre-Installation.” This includes the procurement and installation of all required materials and services to get the room ready for installation of the product. This responsibility includes providing:

- A clean and safe work environment for installation of the product (finished floor, ceiling, walls, and proper room lighting).
- A location suitable for the installation of the product.
- Suitable support structures in the floor, walls, or ceiling necessary for the mounting of the product and/or its components.
- Installation of conduit, ducts and/or raceways necessary to route cables safely.
- Electrical power and grounds of specified quality and reliability.
- Electrical power of the required voltage, including an Emergency-Off safety switch in the room. Power and ground cables to the PDU.
- Properly installed and sized junction boxes, including covers and fittings at locations required and called out in architectural drawings.
- Use GE HealthCare recommended wires and cables as defined in this document.

1.1.3 Site Readiness Checklist

For the site readiness refer to DOC1809666 Global site readiness checklist, (This document is from the GE HealthCare Siting team) for example as below.

Global Site Readiness Checklist (DI)	
Customer Name:	PMI Name:
GON Number:	Field Service Name:
Equipment:	Country / City or City/ State:
Site Visit Date for SRC:	SRC Status:
Site Ready Checks at Installation	Requirement met
General Site Planning	

Room dimensions, including ceiling height, for all Exam, Equipment/Technical and Control rooms meets GE HealthCare specifications.	
Ceiling support structure, if on the GE HealthCare drawing, is at correct location and height according to the drawing specifications. Levelness and spacing has been measured. Over-head support Structure has been confirmed with contractor to meet GE HealthCare criteria.	
Rooms that will contain equipment, including staging areas if applicable, are construction debris free. Precautions must be taken to prevent debris from entering rooms containing equipment.	
Finished ceiling is installed. If applicable ceiling tiles installed per PMI discretion.	
Delivery route from truck to installation space has been reviewed, all communications have occurred, arrangements made for special handling (if needed). Floors along delivery route will support weight of the equipment, reinforcements arranged if needed.	
System power and grounding (PDB/MDP) is available as per GE HealthCare specifications, installed at point of final connection and ready to use. Lock Out Tag Out is available.	
System power and grounded audit has been scheduled to be completed during installation of equipment. (If Required) GE HealthCare PM to confirmed if needed.	
Adequate room illumination installed and working.	
Cable ways (floor, wall, ceiling, etc.) ready for GE HealthCare cables and are of correct length and diameter. Cable-ways routed per GE HealthCare Final drawings and access openings installed as determined by GE HealthCare PM. Surface floor duct installed at time of system installation.	
HVAC systems Installed, and the site meets minimum environmental operational system requirements.	
Network outlets installed and computer network available and working.	
Hospital IT/connectivity contacts have been engaged and information has been added to Project management tool. (If Required)	
Floor levelness/flatness is measured and within tolerance, and there are no visible defects per GE HealthCare specifications. Floor Strength and thickness have been discussed with customer/contractor and they have confirmed GE HealthCare requirements are met.	
Customer supplied counter tops where GE HealthCare equipment will be installed are in place.	
Specific for CT and X-ray	
Doors and windows complete or scheduled to be installed. If applicable, radiation protection (shielding) finished and radio protection regulatory approval for installation obtained.	
PMI Signature:	
Customer Signature:	
FS Signature: optional	

1.2 Common Product Requirements

1.2.1 Dimensions and Layout

Carefully check room layouts for adequate radiographic coverage, necessary clearances and provision for related equipment. Good judgement is required to avoid compromising important features. There must be ample maneuvering space allowed for the hospital cart and for personnel around the table.

1.3 Delivery Requirements

1.3.1 Door Size Requirements

Minimum door sizes also apply to hallway and elevator.

Door Height: The minimum door height accommodated is 190cm (75in) when the Wall Stand is tilted on the dolly.

Door Width:

- The minimum door width to accommodate the Table is: 95cm (37.5in).
- The minimum door width is calculated based on a straight-in approach requiring a 2.5 m (8.20 ft) wide corridor. Minimum widths will change based on narrower corridors.
- The minimum door width to accommodate the OTS about is 1.1 m (44 in) wide.

1.3.2 Minimum Elevator Depth Requirements

The minimum elevator depth to accommodate is 2.45m (96.46in) when the Wall Stand is tilted on the dolly.

1.3.3 Shipping Fixtures and Carts

The extended and standard wall stand is delivered on a fixture.

Figure 1-1 EXT and STD WS Site In-Transit Dimensions

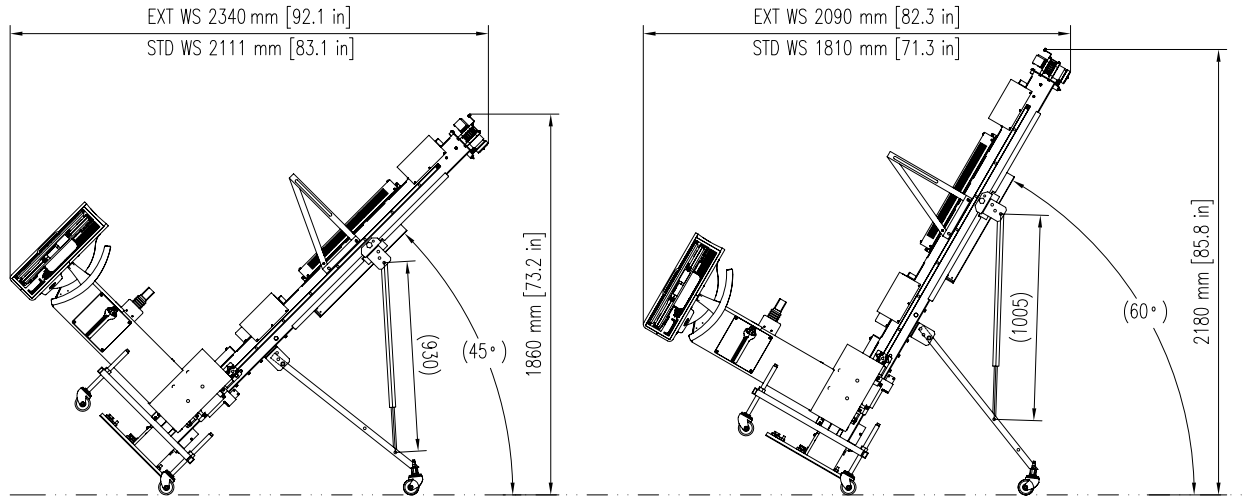

Side View

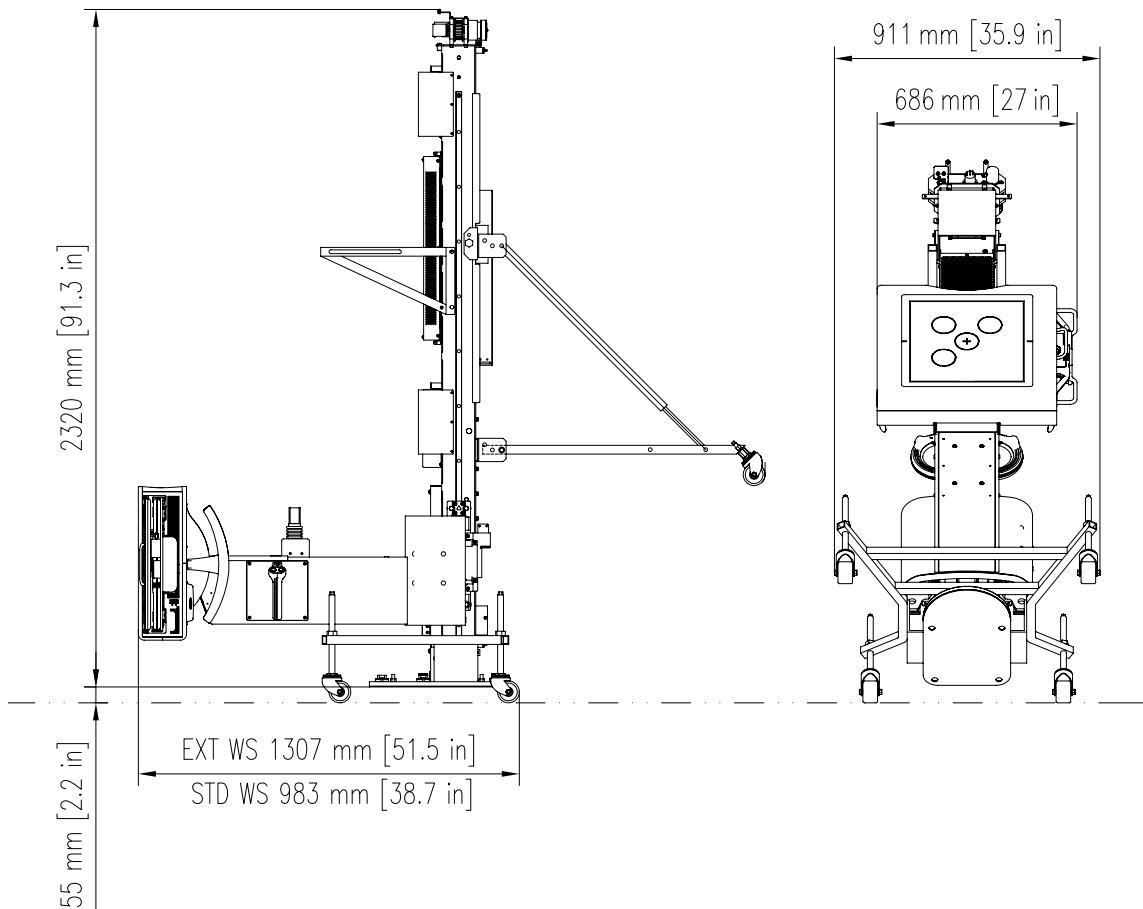

Manual WS is delivered on a fixture.

Figure 1-2 Manual Wallstand Transit Dimensions

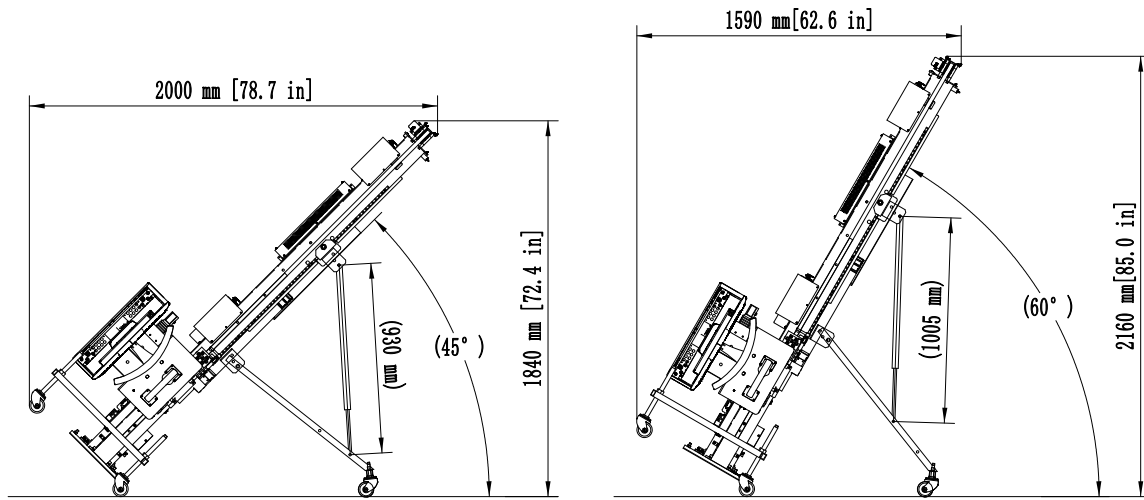

Cabinet

NOTICE

The cabinet can pass up a maximum slope of 10 degrees and pass over a maximum barrier on the floor of 25 mm (0.98 in).

Figure 1-3 Cabinet with its wheels in transit

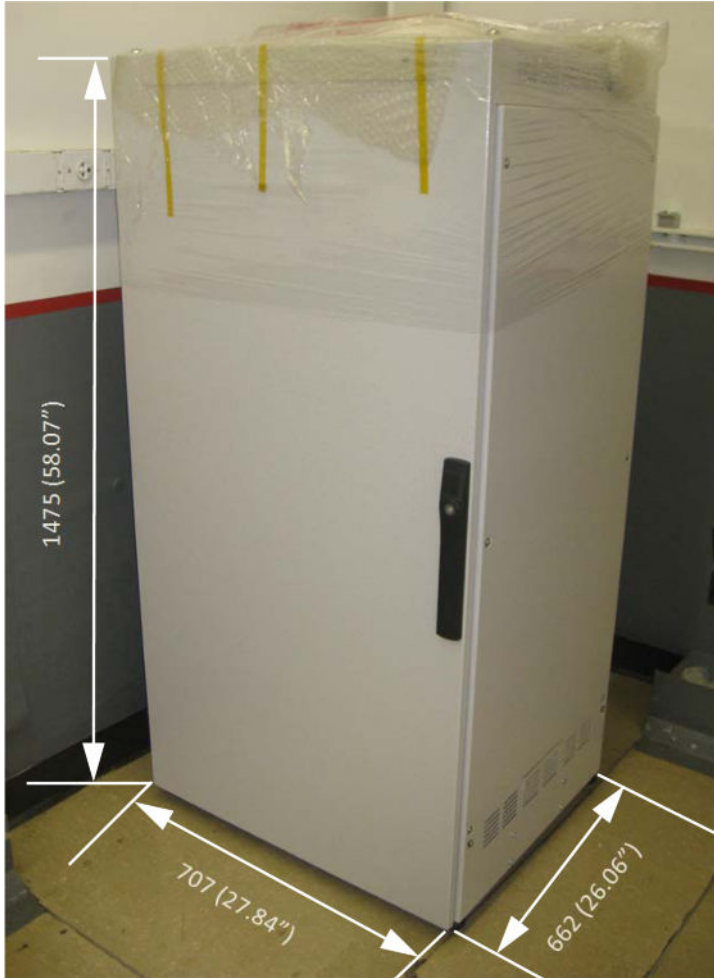

VCP Cabinet

Figure 1-4 VCP Cabinet with its wheels in transit



Table

Figure 1-5 Global G3 Table Package

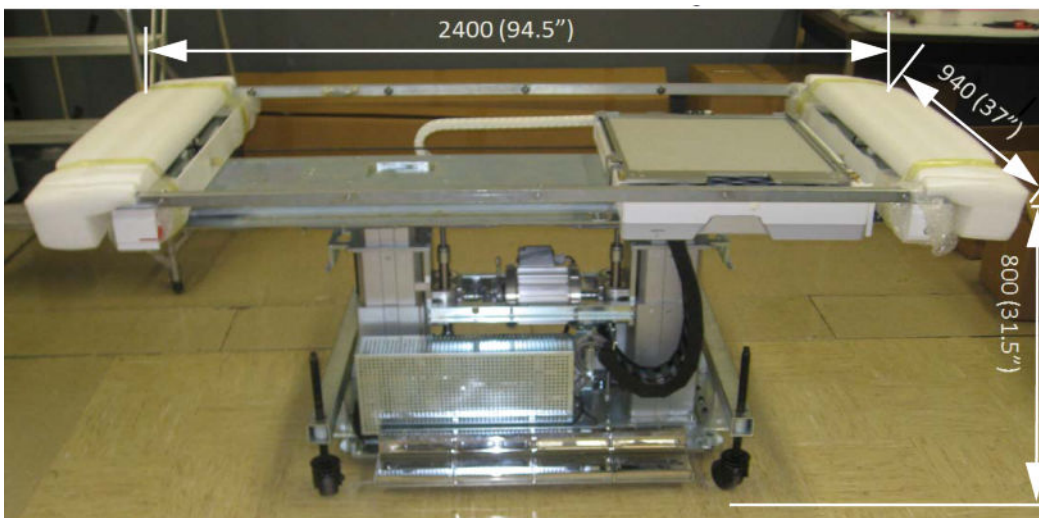
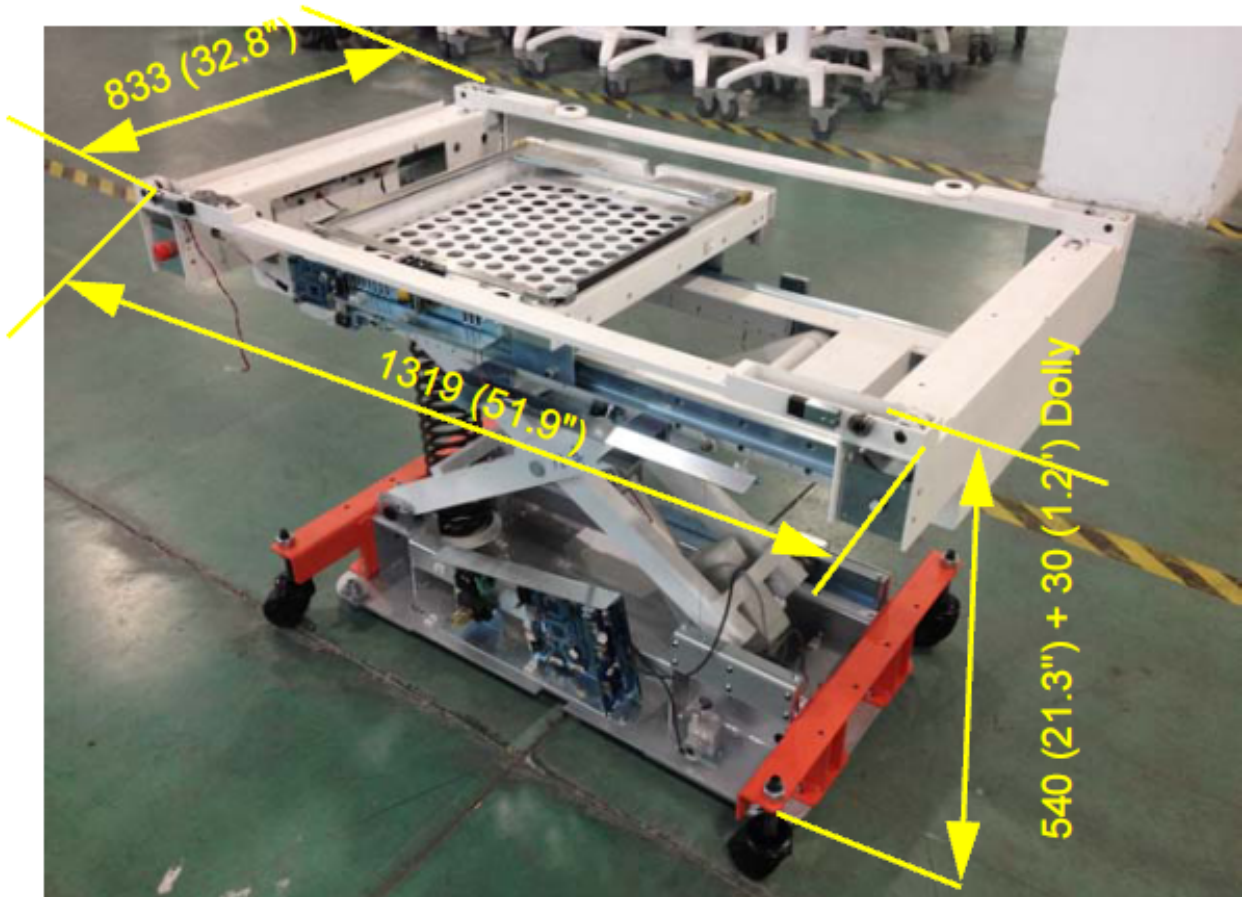

Figure 1-6 Global G3 Std Table Package



Lean Carts

Some system components are packed into two "Lean Carts".

Figure 1-7 Exam Room Lean Cart



Figure 1-8 Control and Options Lean Cart



NOTICE

The dimension of System Accessory Packing Box made in GEHL is 1400*1350*1050

1.3.4 Shipping Dimensions and Weights

Table 1-1 SHIPPING DATA

Component	Shipping Data				
	Shipping Dimensions (Approx)			SHIPPING WEIGHT (approx)	SHIPPING METHOD
	Length	Width	Height		
Stationary Rail (4m) (set of 2 rails)	4400mm (14.4ft)	62.5mm (2.46in)	84.3mm (3.32in)	48kg (106lbs)	box
2 Meter Bridge	3170mm (10.4ft)	800mm (31.5in)	475mm (18.7in)	204kg (449.8lbs)	box/crate/skid
3 Meter Bridge and cable	3350mm (11ft)	650mm (25.6in)	550mm (21.7in)	245kg (540lbs)	box/crate/skid
Cable Drape Rail and Support	813mm (32in)	584mm (23in)	229mm (9.02in)	82.5kg (182lbs)	box/skid
System Cabinet	910 mm (35.8 in)	780 mm (30.7 in)	1650 mm (65in)	353 kg (778 lbs)	box
System Cabinet in Transit	856mm (33.3 in)	662 mm (26 in)	1475 mm (58 in)	320 kg (705 lbs)	skid
VCP Cabinet	1100mm (43.31inch)	840mm (33.07inch)	1130mm (44.49inch)	247kg (544.5lbs)	Box
VCP Cabinet in Transit	900mm (35.43inch)	600mm (23.62inch)	932mm (36.69inch)	198kg (436.5lbs)	skid

Table 1-1 SHIPPING DATA (Table continued)

Component	Shipping Data				
	Shipping Dimensions (Approx)			SHIPPING WEIGHT (approx)	SHIPPING METHOD
	Length	Width	Height		
Standard Wall Stand	2560mm (100.8in)	1110mm (43.7in)	1350mm (53in)	449kg (990lbs)	crate / skid
Standard Wall Stand in Transit	2111mm (83.1in)	911mm (35.9in)	1860mm (73.2in)	260kg (573lbs)	dolly
Extended Wall Stand	2560mm (100.8in)	1110mm (43.7in)	1670mm (66in)	459kg (1012lbs)	crate / skid
Extended Wall Stand in Transit	2340mm (92.1in)	911mm (35.9in)	1860mm (73.2in)	280kg (617lbs)	dolly
Manual Wall Stand	2560mm (100.8in)	1110mm (43.7in)	1900mm (75in)	449kg (858lbs)	crate / skid
Manual Wall Stand in Transit	2000mm (78.7in)	911mm (35.9in)	1840mm (72.4in)	260kg (573lbs)	dolly
Detector 17x17 in Package	711mm (29in)	661mm (26in)	280mm (11in)	18kg (39.6lbs)	crate
Detector 14x17 in Package	711mm (29in)	661mm (26in)	280mm (11in)	16kg (35.3lbs)	crate
Detector 10x12 in Package	623mm (24.5in)	483mm (19in)	280mm (11in)	9.6kg (21lbs)	crate
Global G3 Table Assembly in Package	2600mm (102in)	1240mm (48.82in)	870mm (34.25in)	486kg (1071.5lbs)	box / skid
Global G3 Table in Transit	2350mm (93in)	940mm (37in)	800mm (31.5in)	380kg (838lbs)	dolly
Table Assembly in Package (Standard Table)	1540mm (61in)	940mm (37in)	1110mm (44in)	275kg (606lbs)	box / skid
Table in Transit (Standard Table)	1319mm (52in)	833mm (33in)	570mm (22.4in)	267.5kg (589.7lbs)	dolly/skid
Tabletop assembly in package (Standard Table)	2470mm (97in)	980mm (47.24in)	240mm (12.60in)	78kg (172lbs)	box
Tabletop in transit (Standard Table)	2330mm (92in)	838mm (32.99in)	43mm (1.69in)	40kg (88lbs)	
Radiographic Stretcher (Option)	2188mm (86in)	917mm (36in)	750mm (30in)	164kg (362lbs)	skid
Carbon Fiber Stretcher (Option)	2200mm (87in)	650mm (26in)	700mm (28in)	70kg (154lbs)	skid
GST-2 Stretcher (Option)	2004mm (79 in)	640mm (25 in)	696mm (27 in)	50kg (110lbs)	skid
Exam Room Lean Cart	2134mm (84.02in)	762mm (30in)	1524mm (60in)	varies	wheeled cart
Control and Options Lean Cart	1308mm (51.5in)	762mm (30in)	1397mm (55in)	varies	wheeled cart
Detector Bin	540mm (21.26in)	360mm (14.18in)	120mm (4.73in)	15kg (33lbs)	box

Table 1-1 SHIPPING DATA (Table continued)

Component	Shipping Data				
	Shipping Dimensions (Approx)			SHIPPING WEIGHT (approx)	SHIPPING METHOD
	Length	Width	Height		
Overhead Tube Suspension (OTS) in Package	1190mm (39.4in)	1040mm (41.4in)	1640mm (67in)	380kg (838lbs)	crate
Overhead Tube Suspension (OTS) in transit	900mm (35.4in)	940mm (37in)	1020mm (40in)	217kg (478lbs)	crate
Patient Barrier	1000mm (39.4in)	600mm (23.6in)	1800mm (70.9in)	80kg (176.4lbs)	box
410mm Footstool for Patient Barrier	1040mm (41in)	850mm (33.5in)	550mm (21.7in)	17kg (37.5lbs)	box

1.3.5 Preparing the Delivery Route

1. Sketch the area of the hospital or clinic which will receive the equipment. Include all areas on the delivery route from outside of building to destination.

NOTICE

The reference numbers in circles refer to the Route Survey data shown in the following figure. The Route Survey is a form on which site data is listed.

Figure 1-9 Sample Route

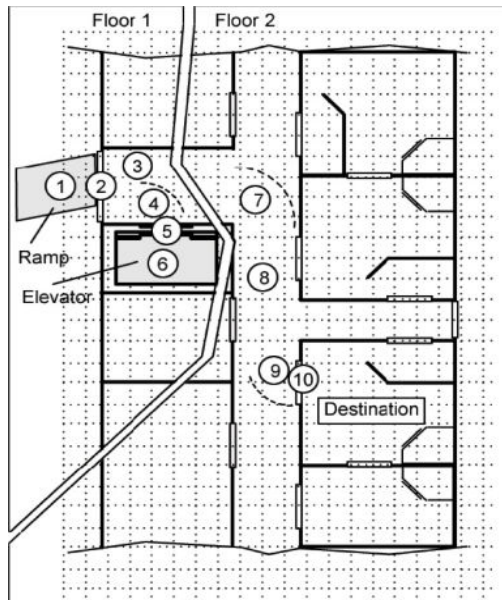

2. Record all loading capacities, corridor widths, door openings, turning radii, flooring materials, elevator sizes, obstructions and so on for reference.
3. Verify that the equipment can be transported via the route determined.

2 Equipment

2.1 System Components

2.1.1 System Components

This system may consist of the following main components:

1. Operator Console. (monitor, keyboard, mouse, MPC, RCIM2, bar code reader and hand switch)
2. System Cabinet
3. Elevating Table (GlobalG3Table or GlobalG3StdTable)
4. Bridge
5. Overhead Tube Support (OTS)
6. X-Ray Tube
7. Collimator
8. UIF
9. Wall Stand (Standard WS or Extended WS or Manual WS)
10. Flash Pad HD Detector
11. AP Assembly (without AP in Non wireless system)
12. Grid Holder
13. VCP cabinet

**NOTE**

The PC cannot be put on the ground directly.

Figure 2-1 System Component Identification

2.1.1.1 Optional Components

The system can include the following free-standing components, which can be purchased as options:

1. Radiographic Stretcher
2. GST Stretcher/ S1700JM Carbon Fiber Stretcher (US Region Only)
3. Elevation stretcher *
4. Image Pasting Patient Barrier
5. UPS
6. Detector BIN
7. Detector Handle
8. Detector WBC
9. TIB (Option for G3B or later)

- 10. Detector Battery
- 11. Detector Battery Charger
- 12. Camera
- 13. Higher Capacity Battery charger with cable



NOTE

- Camera (Item 12) is optional for Gen5.
- Higher Capacity Battery charger (item12) cover two type batteries (10X12 & 14X17). Power supply integrated in Charger. Power switch could be on or off when needed. The dust cover protects the charger connector. Dimension is 328*145*150. Charging time is within 2.5h to 3h.

Figure 2-2 Optional System Component Identification



2.1.2 Room Requirements

2.1.2.1 Acoustic Output

Table 2-1 System Acoustic Output

COMPONENT	SOUND OUTPUT (dBA)	
	IN-USE (measured 1m from any point in system)	STAND-BY (measured 1m from any point in system)
System	<60	<55

2.1.2.2 Floor Requirements

The preferred method of installing the wall stand is to use the provided typical floor anchors (Non-Seismic ONLY).

2.1.2.2.1 Floor Levelness Specifications

Critical Specifications

Accurate patient positioning during scanning depends on proper alignment of the gantry and the table. The floor levelness specification in the following table ensure that the table and gantry height adjusters have enough range to allow proper leveling of the system.

Table 2-2 Critical specification for floor levelness

Specification	Metric(minimum)	English(minimum)
Levelness	6mm maximum variance over 3048mm	1/4 in. maximum variance over 10 ft

2.1.2.2.2 Floor Requirements When Using Provided Typical Floor Anchors

CAUTION



Concrete area for wall stand installation should be 1 m² (1550 in²).

Anchors must be a minimum of 90 mm (3.54 in) from any concrete edge including ducts and cracks. In addition, the general condition of the concrete in the immediate mounting area should be inspected to ensure that anchors will be set in good quality concrete.

NOTICE

Recommended concrete strength is B40 or equivalent.

The floor bearing the system is recommended to be concrete and the thickness to be determined by a Structural Engineer to properly support the equipment loads. The supplied anchors require a minimum embedment of 90 mm (3.54 in) into the concrete. If the floor thickness is less than 95 mm (3.74 in), it is recommended that the unit be secured using a through-bolt method with a reinforcement plate on the back side.

Figure 2-3 Typical Floor Anchors

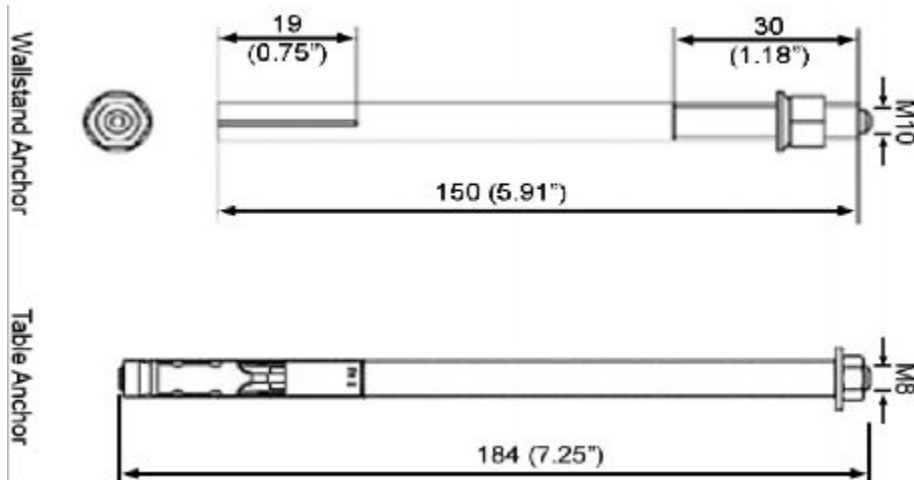
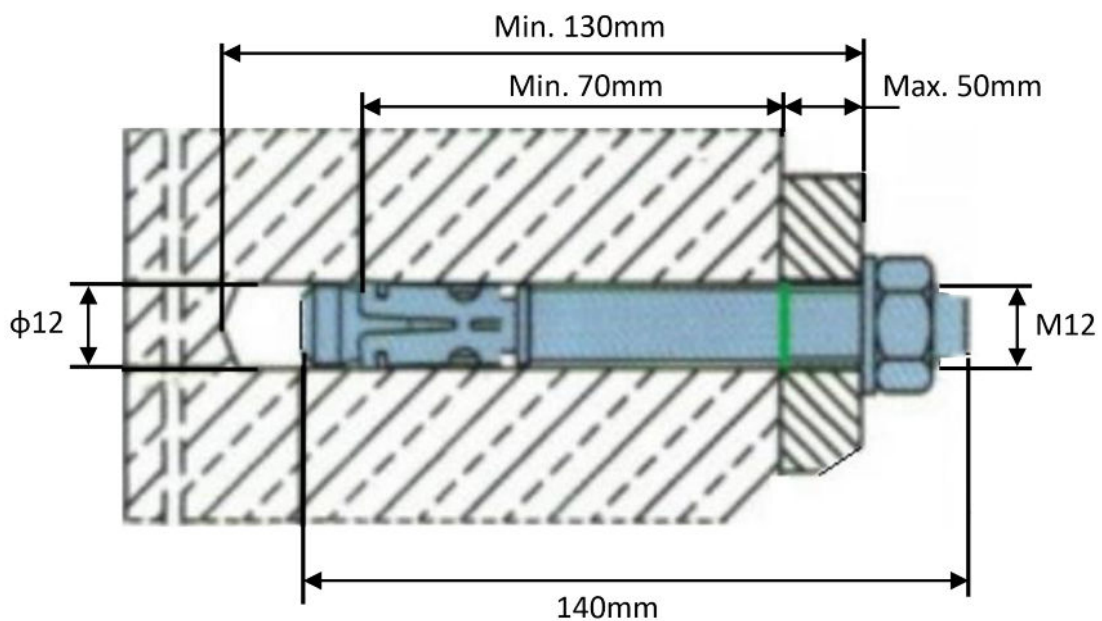

Figure 2-4 Optimized anchor bolts

Stainless Steel A2-70 with Hex Nut (GB/T 6170 M12) and large plain washer (GB/T 96.1 12)

Apply to Wallstand (Ext/Std) and GlobalG3Table.



2.1.2.2.3 Pan-Type Floor Construction Requirement

For pan-type floor construction, steel channels must be designed by a local structural engineer to span floor joists.

Figure 2-5 Thru-Bolt Floor Mounting (Pan-Type Floor Construction)

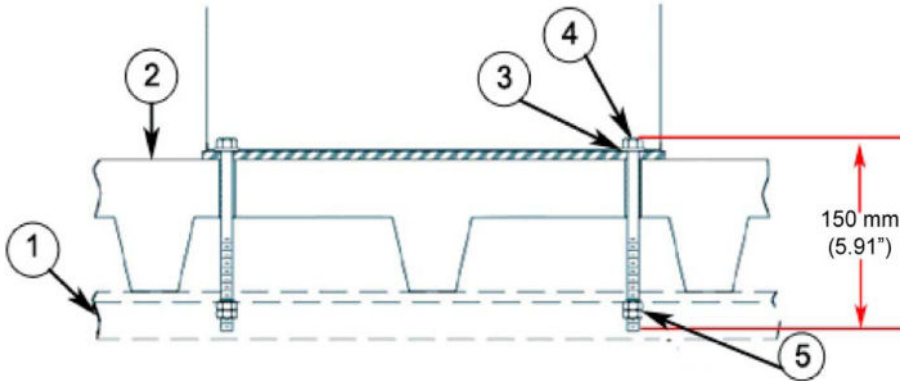

Item	Description
1	For Pan-Type Floor Construction Joists Must Be Spanned With Steel Channels (Customer Furnished)
2	Floor
3	Flat Washer
4	Thru Bolt for 16 mm (Hole Of Appropriate Length.)
5	2-Hex Nuts

2.1.2.2.4 PC Floor Mounting Requirement for Seismic Region

1. Drill four holes on the floor per below base plate dimension, depth \geq 30mm.
2. Mount the base pate with four anchors, tighten the anchor nuts (torque reference, 5Nm), and do marks.
3. Put the computer on the base plate and fix it with the belts, refer to below picture.
4. Connect the GND cable with base plate and computer ground stud.

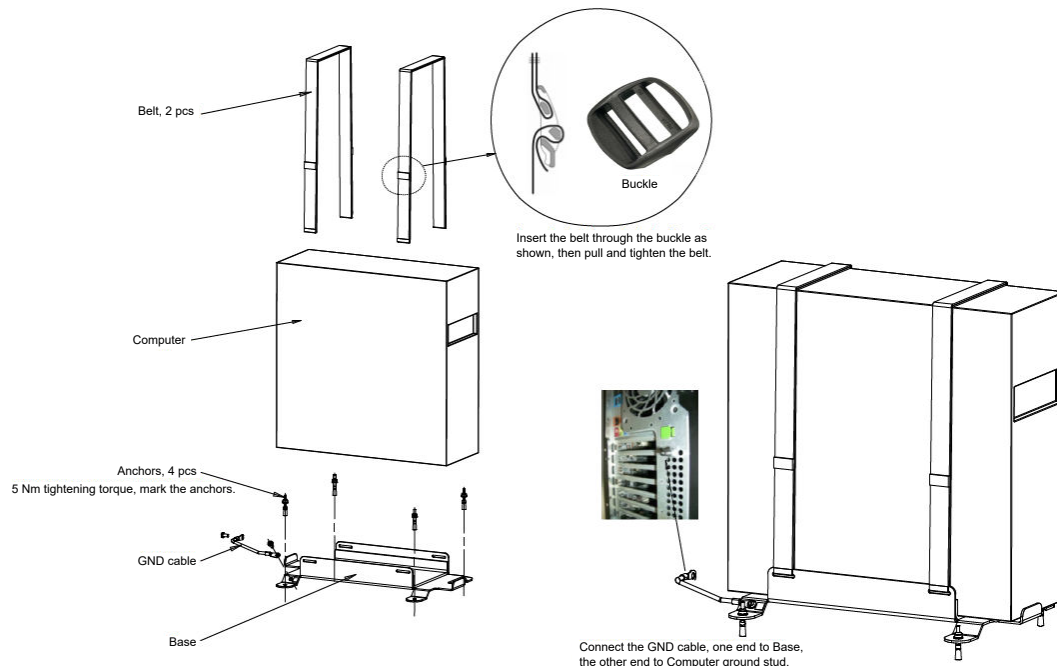

2.1.2.3 Ceiling Requirements

- To allow installation of the stationary rail cross-members, clearance is required between the ends of the stationary rails and the walls.
- It is recommended that sprinkler heads not be placed between the stationary rails. All sprinkler heads should be mounted so they do not extend downward more than 1/4" (6.35 mm) from the ceiling while in the 'resting' position.
- In addition, there should not be anything mounted in the ceiling (i.e. lights, A/C returns, etc) between the stationary rails. This is because the OTS longitudinal drive belt assembly is located on the movable bridge, approximately centered between the two stationary rails, and may come into contact with those ceiling-mounted items during normal use.

2.1.2.3.1 Rail and Bridge and Room Heights

Complete details of room dimensions must be known when planning an installation. Work with the architect or building engineer and obtain approval from the customer before proceeding with the layout plan.

Methods of support that will permit attachment to structural steel or through bolts in concrete construction should be favored. Do not use anchors in direct tension. Each rail has mounting holes on 660.4mm (26 in) centers with the first hole located 55 mm (2 in) from the rail mount end. The last hole is located either 55mm (2in) from the other end with a variable space of less than 660.4mm (26in) between it and the second last hole.

Table 2-3 Recommended and Minimum Room Heights (Floor to Top of Longitudinal Rail)

Configuration		Specifications	Ceiling
All	2M or 3M Bridge	Recommended	2836 mm (111.65")
	2M or 3M Bridge with WS at head side	Minimum	2705 mm (106.5")
Drape	2M or 3M Bridge with WS at foot side	Minimum	2686 mm (105.75")
Chain	2M or 3M Bridge with WS at foot side	Minimum	2725 mm (107.28")

Figure 2-6 Wallstand at Foot position Ceiling Minimum 2725mm (107.28’')

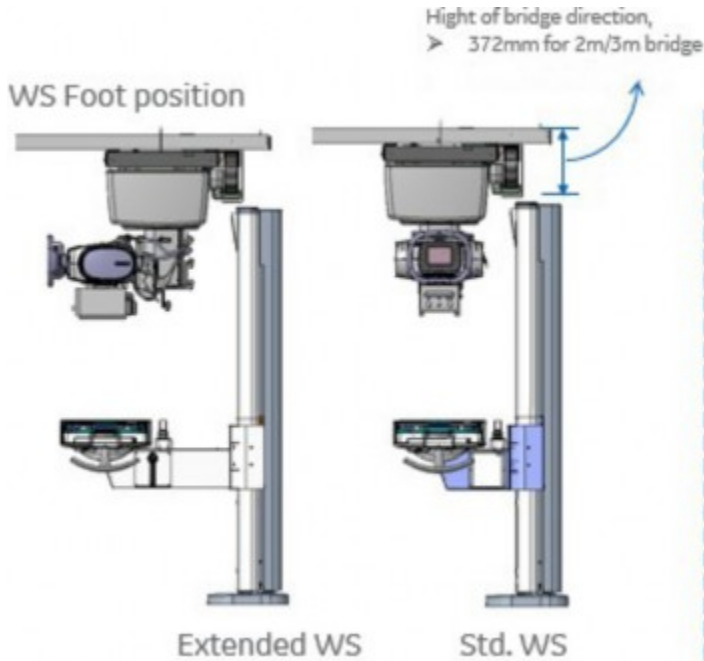
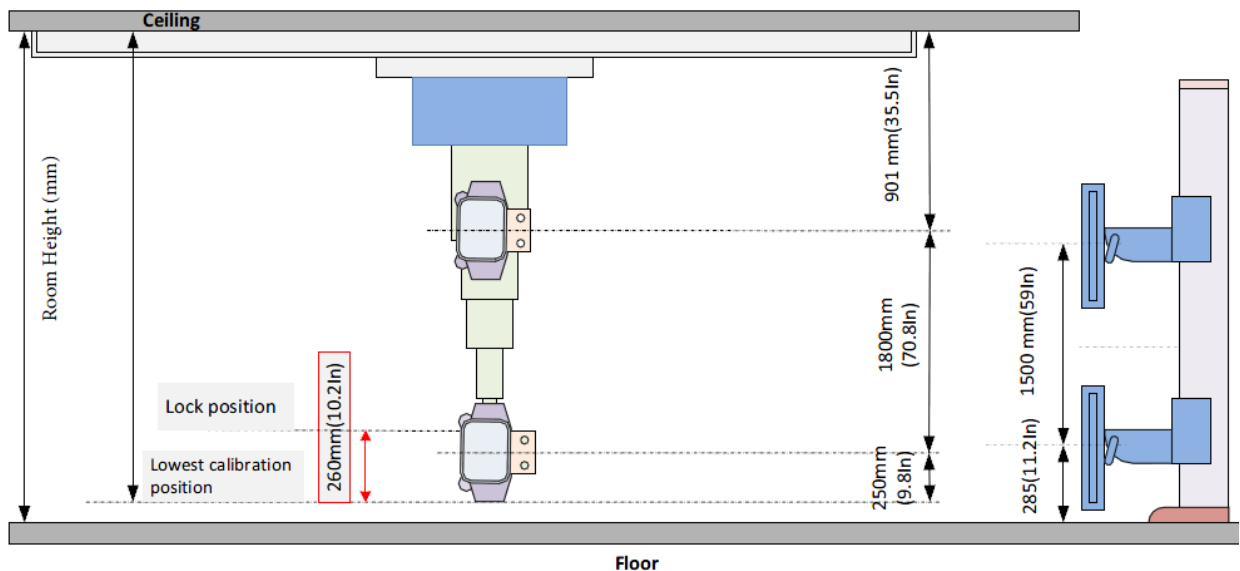

Figure 2-7 Recommended Ceiling Height 2836 mm (111.6’')



- When Lowest point of OTS could touch floor, keep OTS SID=1800mm, Height=901+1800+250=2951mm
- When OTS center is parallel to WS center at lowest position of OTS, OTS SID=1800mm, Height=901+1800+285=2986mm
- When OTS center is parallel to WS center at highest position of WS, keep WS travel range=1500mm, Height=901+1500+285=2686mm
- When OTS with cable chain, to avoid the cable chain conflict with WS top cover, Height = bridge direction bracket height from ceiling 372+ WS height 2325 = 2697mm



NOTE

After calculated image pasting scenario based on software package and new patient barrier (19.7cm height platform), the relationship between ceiling height and footstool was shown in below table.

Table 2-4 Ceiling Height With Footstool

Ceiling Height (mm)	Comments
2686 ~ 2966 (105.7" ~ 116.8")	Patient barrier platform (197mm) only, No need for footstool
2966 ~ 3036 (116.8" ~ 119.5")	Need 267mm footstool
3036 ~ 3179 (119.5" ~ 125.2")	Need 410mm footstool

Figure 2-8 Patient Barrier Platform With Footstool

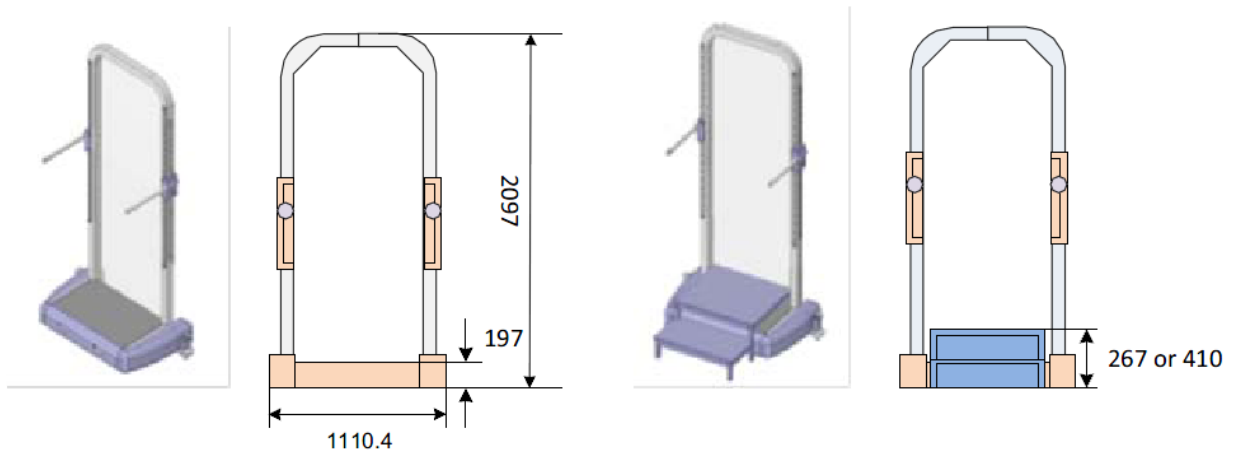

NOTICE

Referring to the layout drawings, the ± 3 mm (1/8 inch) requirement for parallelism of the stationary rail is critical. Therefore, great care must be exercised in locating the mounting points. [Figure 2-9 3 Meter Bridge Specifications for a Typical 4064mm \(13 foot - 4 inch\) Stationary Rail Mounting Interface \(Both Rails Ceiling Mounted\)](#) on page 43 through [Figure 2-10 2 Meter Bridge Specifications for a Typical 4064mm \(13 foot - 4 inch\) Stationary Rail Mounting Interface \(Both Rails Ceiling Mounted\)](#) on page 45 outline requirements that the stationary rail mounting interface must meet.

For site planning, please refer to the Illustrations in the OTS section of Chapter 2 - Equipment / System Component Dimensions and Weights.

For low ceiling height, the stationary rails may be mounted directly to the ceiling slab or to flush mounted Unistrut or similar structure. For higher rooms in which a false ceiling is to be used, the stationary rails may be attached to rigid vertical members hung from the ceiling slab. A supplementary channel may be secured to the bottom of the vertical members to facilitate provision for mounting holes. A Unistrut system or equivalent is a convenient type of support to employ.

Figure 2-9 3 Meter Bridge Specifications for a Typical 4064mm (13 foot - 4 inch) Stationary Rail Mounting Interface (Both Rails Ceiling Mounted)

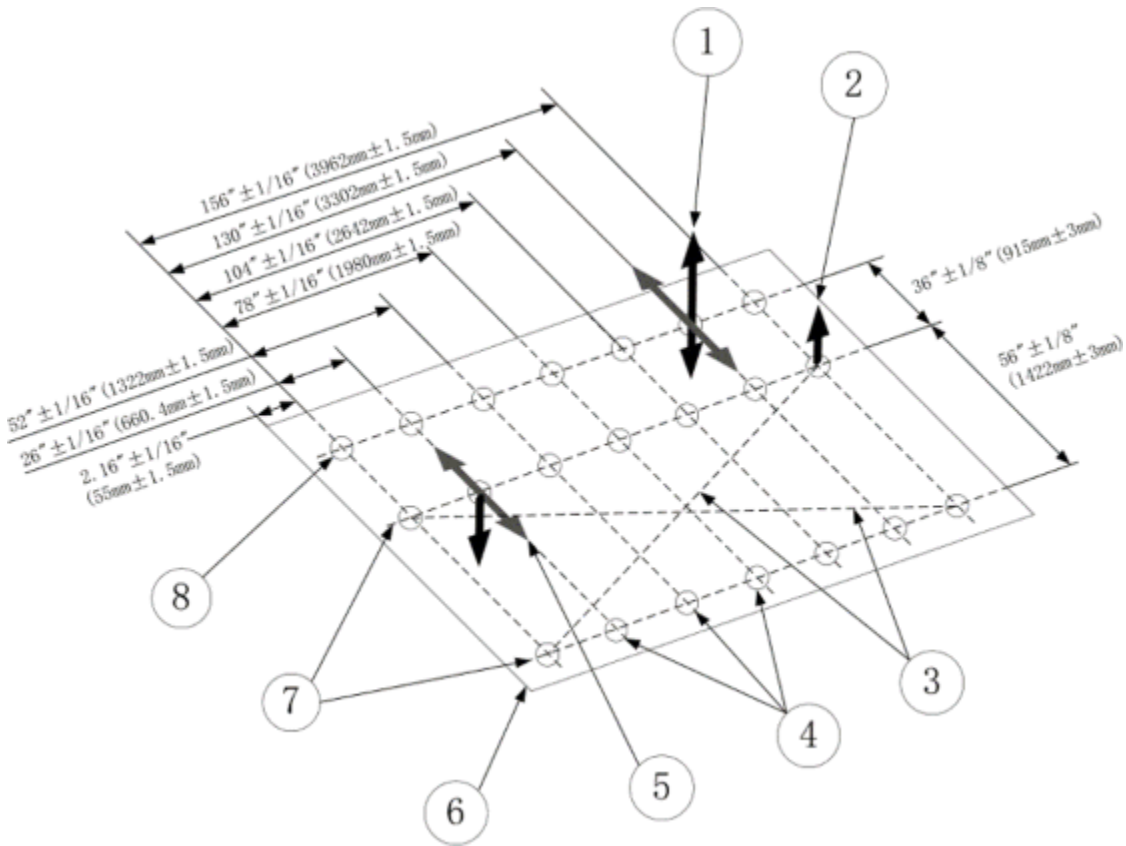

9

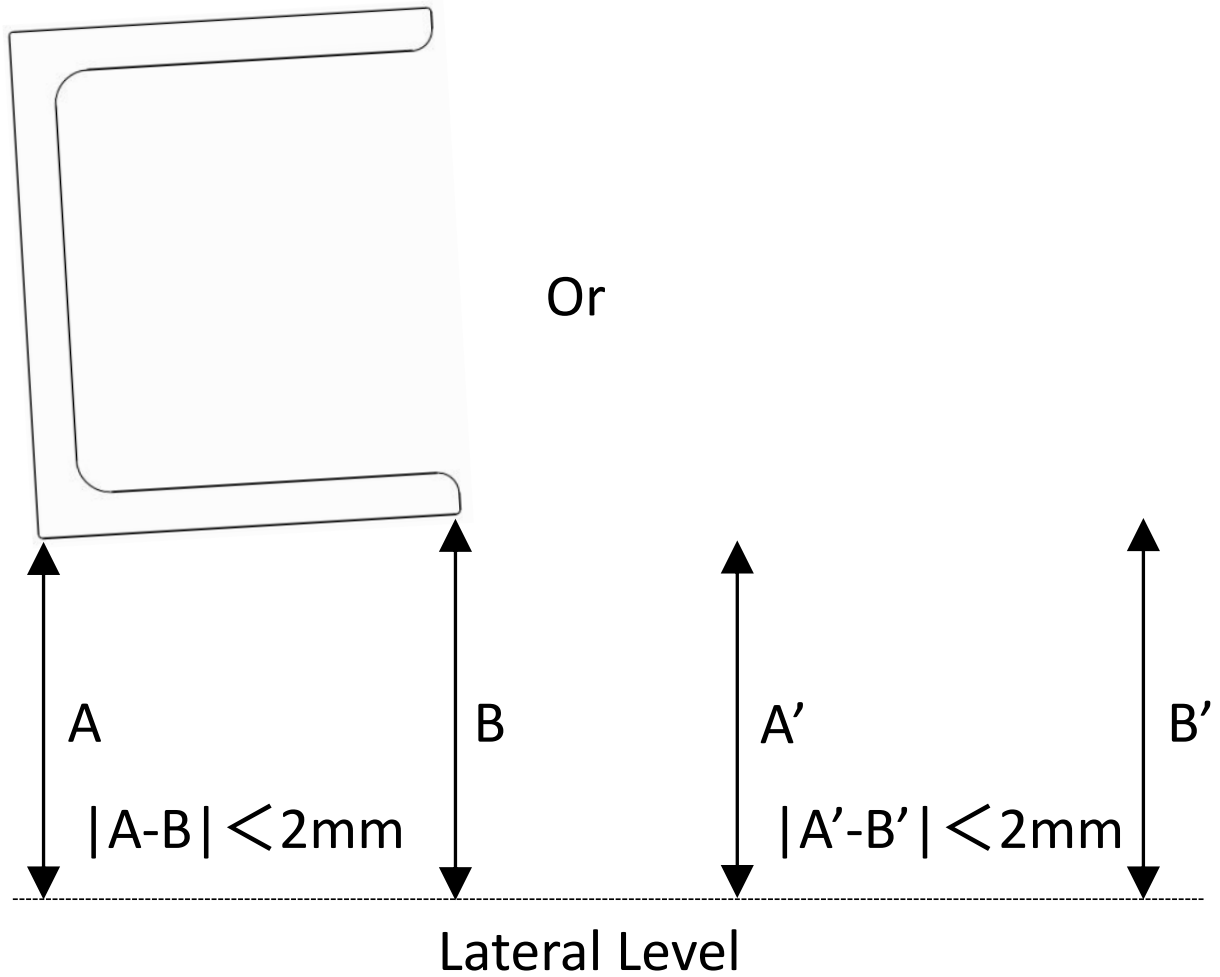

Item	Description
1	When a 50 lb. (22.7 kg) force is applied vertically upward, vertically downward, or horizontally at any support rail mounting point, the attachment interface must not deflect more than 1/16" (1.5 mm).
2	When a 100 lb. (45.4 kg) force is applied vertically upward at any stationary rail mounting point, the attachment interface MUST not deflect more than 1/16" (1.5 mm).
3	Diagonals must be equal within $\pm 1/4"$ (6.5 mm).
4	All mounting points must be located on a common centerline within $\pm 1/16"$ (1.5 mm).
5	When a 300 lb. (136 kg) load is applied vertically downward or horizontally at any stationary rail mounting point, the attachment interface MUST not deflect more than 1/16" (1.5 mm).
6	All mounting points must be in the same horizontal plane within $\pm 3/32"$ (2.4 mm)
7	Stationary rail mounting points must be parallel within $\pm 1/8"$ (3 mm)
8	The bottom surface of stationary rail and cable support rail must be flat, no obvious protrusions large than 1mm. (only applied for non-Unistrut construction)
9	The bottom surface of the stationary rail and cable support rail must be horizontal, the angle along the lateral direction must be less than 2 degree(vertical height less than 2mm).

Figure 2-10 2 Meter Bridge Specifications for a Typical 4064mm (13 foot - 4 inch) Stationary Rail Mounting Interface (Both Rails Ceiling Mounted)

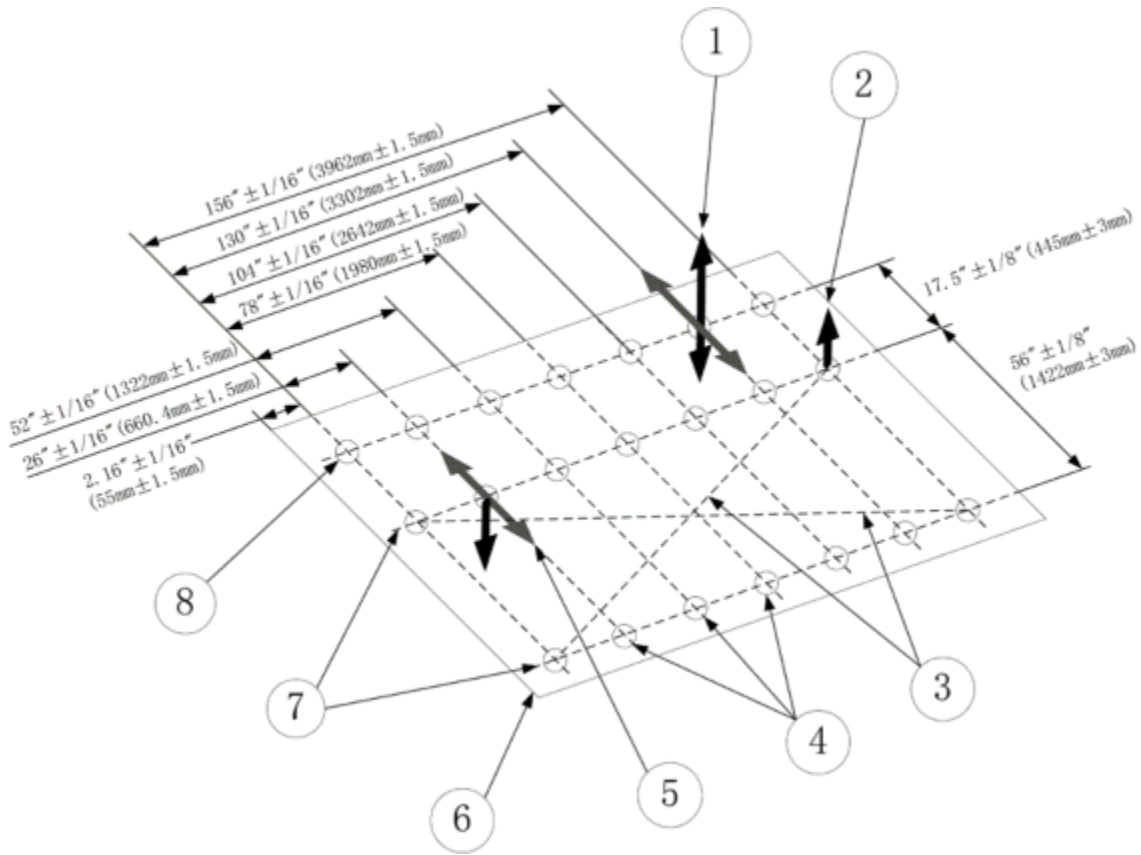

9

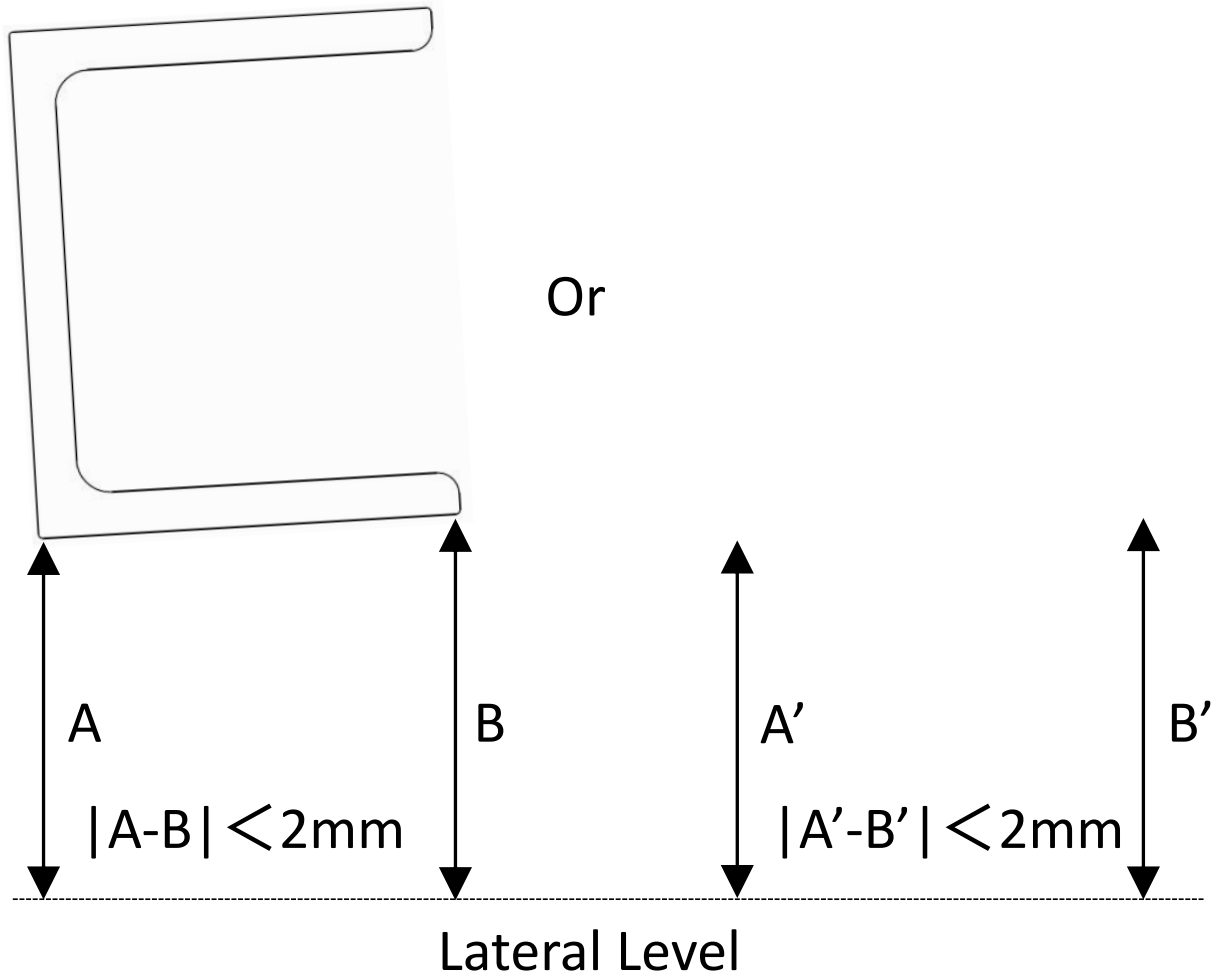

Item	Description
1	When a 50 lb. (22.7 kg) force is applied vertically upward, vertically downward, or horizontally at any support rail mounting point, the attachment interface must not deflect more than 1/16" (1.5 mm).
2	When a 100 lb. (45.4 kg) force is applied vertically upward at any stationary rail mounting point, the attachment interface MUST not deflect more than 1/16" (1.5 mm).
3	Diagonals must be equal within ±1/4" (6.5 mm).
4	All mounting points must be located on a common centerline within ±1/16" (1.5 mm).
5	When a 300 lb. (136 kg) load is applied vertically downward or horizontally at any stationary rail mounting point, the attachment interface MUST not deflect more than 1/16" (1.5 mm).
6	All mounting points must be in the same horizontal plane within ±3/32" (2.4 mm)
7	Stationary rail mounting points must be parallel within ±1/8" (3 mm)
8	The bottom surface of stationary rail and cable support rail must be flat, no obvious protrusions large than 1mm. (only applied for non-Unistrut construction)
9	The bottom surface of the stationary rail and cable support rail must be horizontal, the angle along the lateral direction must be less than 2 degree(vertical height less than 2mm).

Figure 2-14 Stationary Rail Mounting Locations and Clearances with 3M Bridge and cable chain

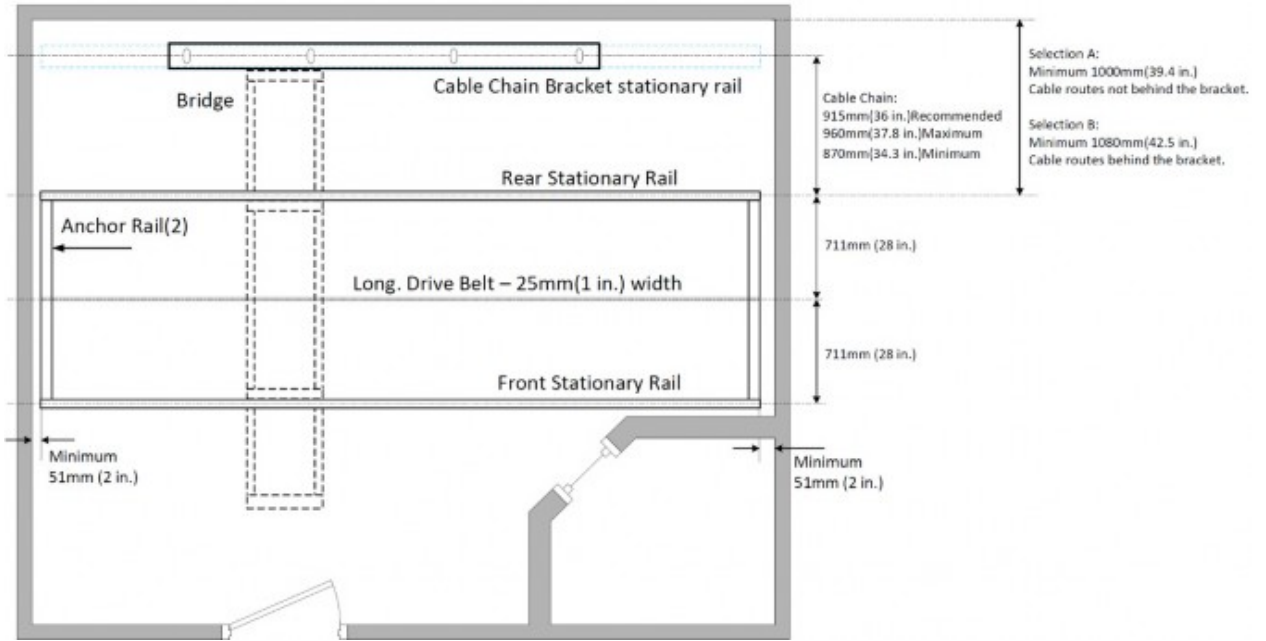

Figure 2-15 Stationary Rail Mounting Locations and Clearances with 2M Bridge and Cable Drape

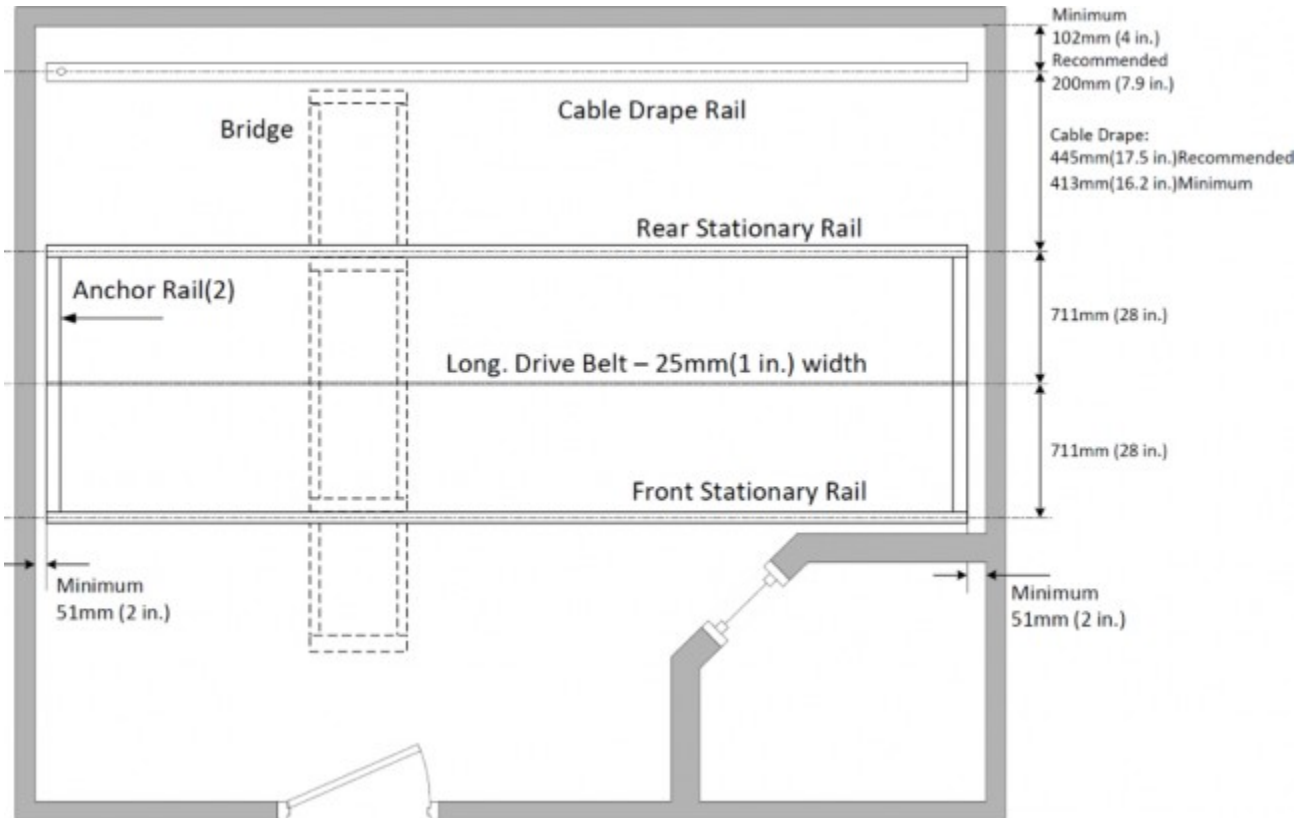
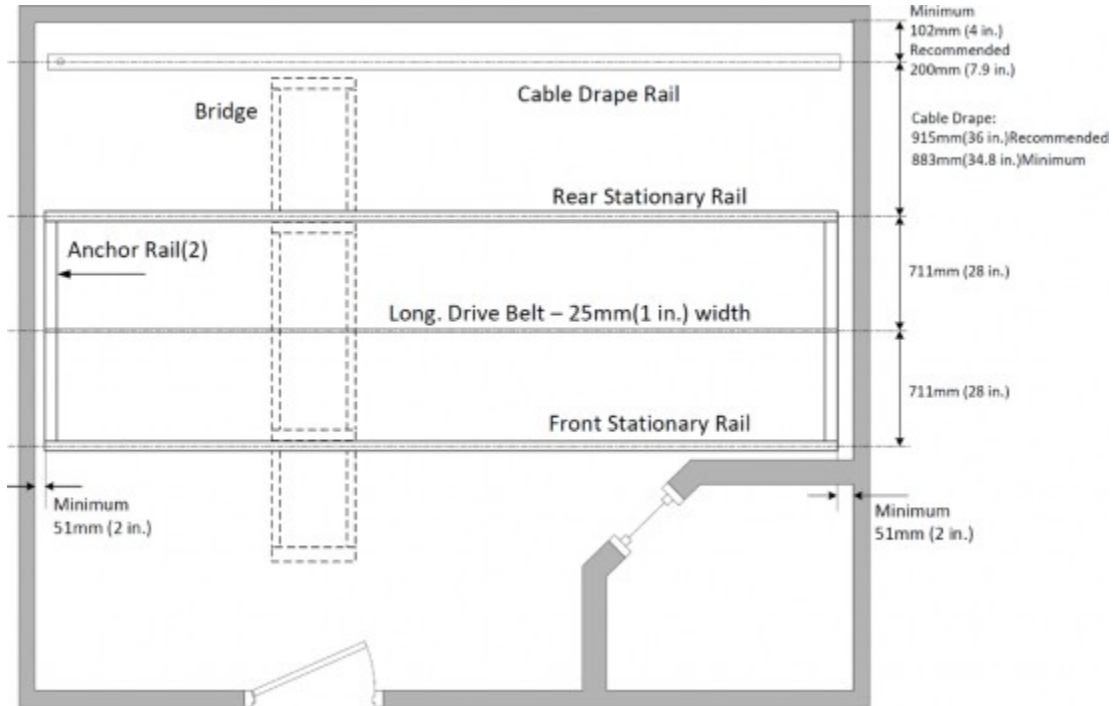
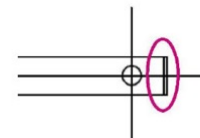
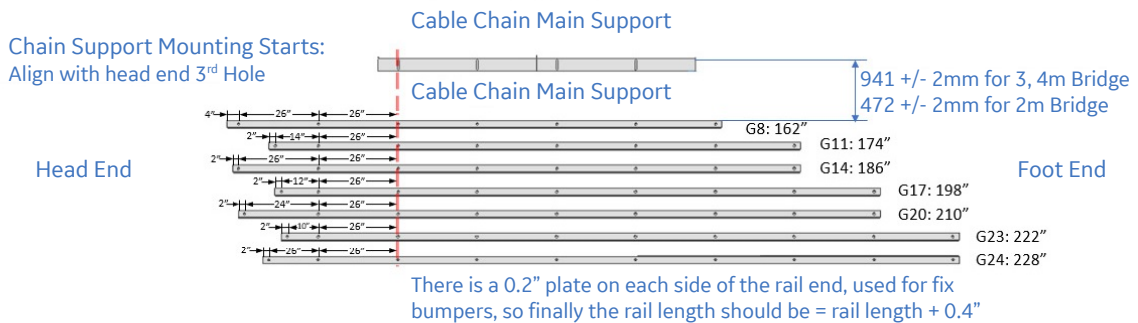

Figure 2-16 Stationary Rail Mounting Locations and Clearances with 3M Bridge and Cable Drape



2.1.2.3.2 Cable Chain Support Location

- For the cable chain configuration, the cable chain installed position need to meet the requirements with different length rail.
- For the cable drape configuration, please skip this section.



2.1.2.3.3 12m Rail Mounting Requirement

Figure 2-17 Specifications for a 12M Rail (12.192m (40ft)) Stationary Rail Mounting Interface (Both Rails Ceiling Mounted) with 2M/3M Bridge

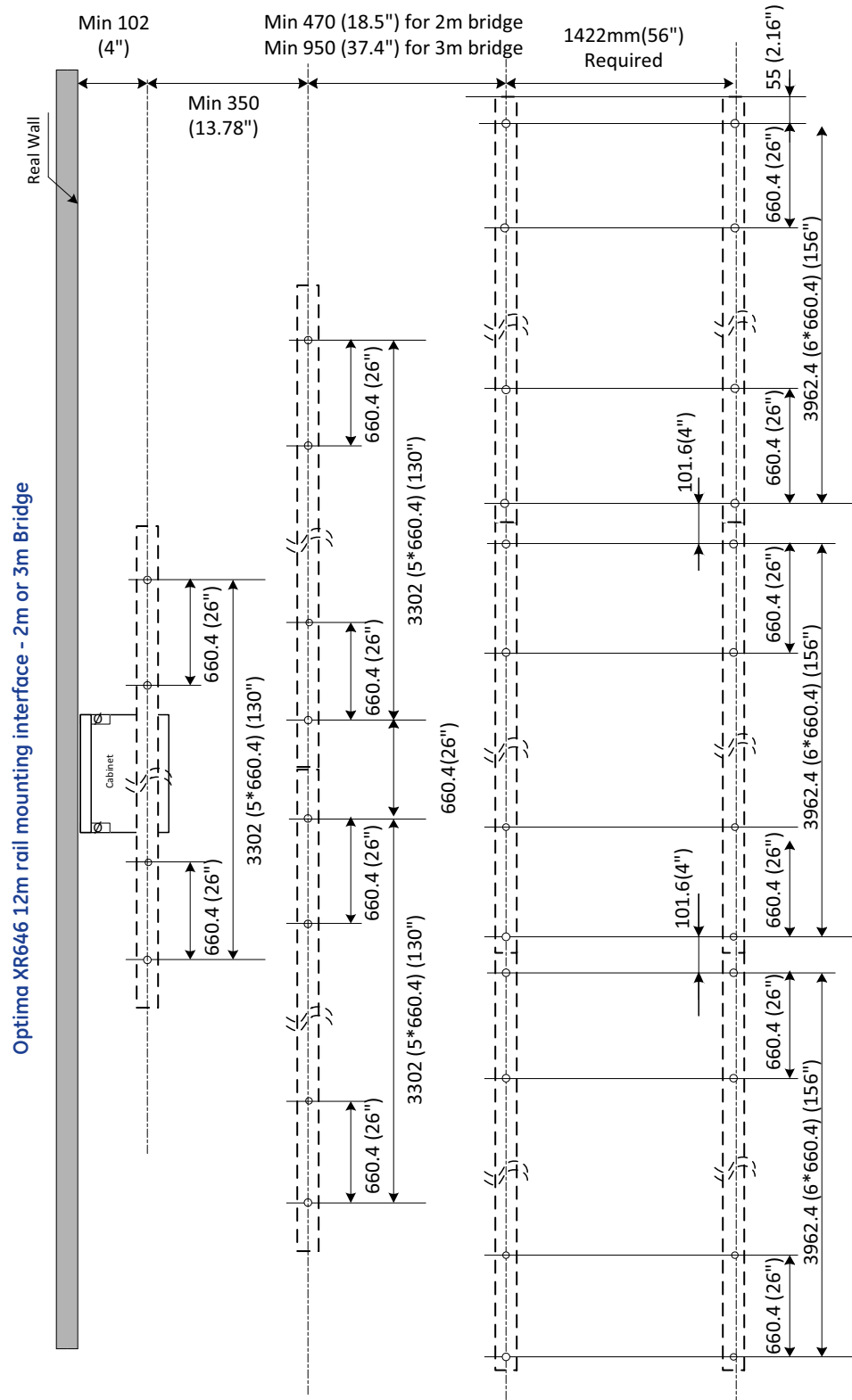

Figure 2-18 OTS Cable Drape Routing

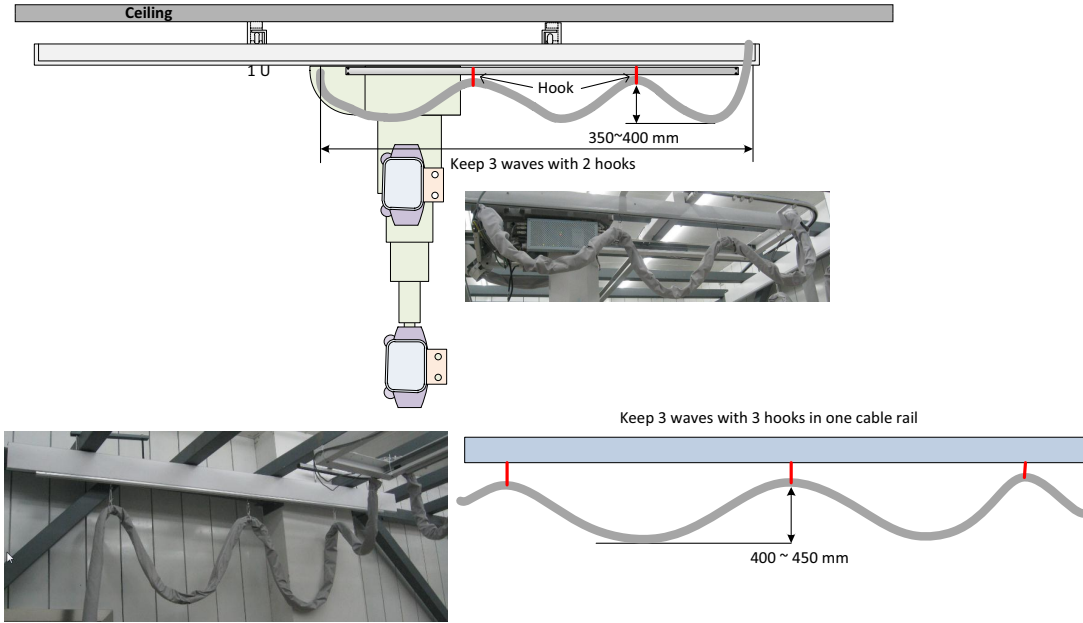
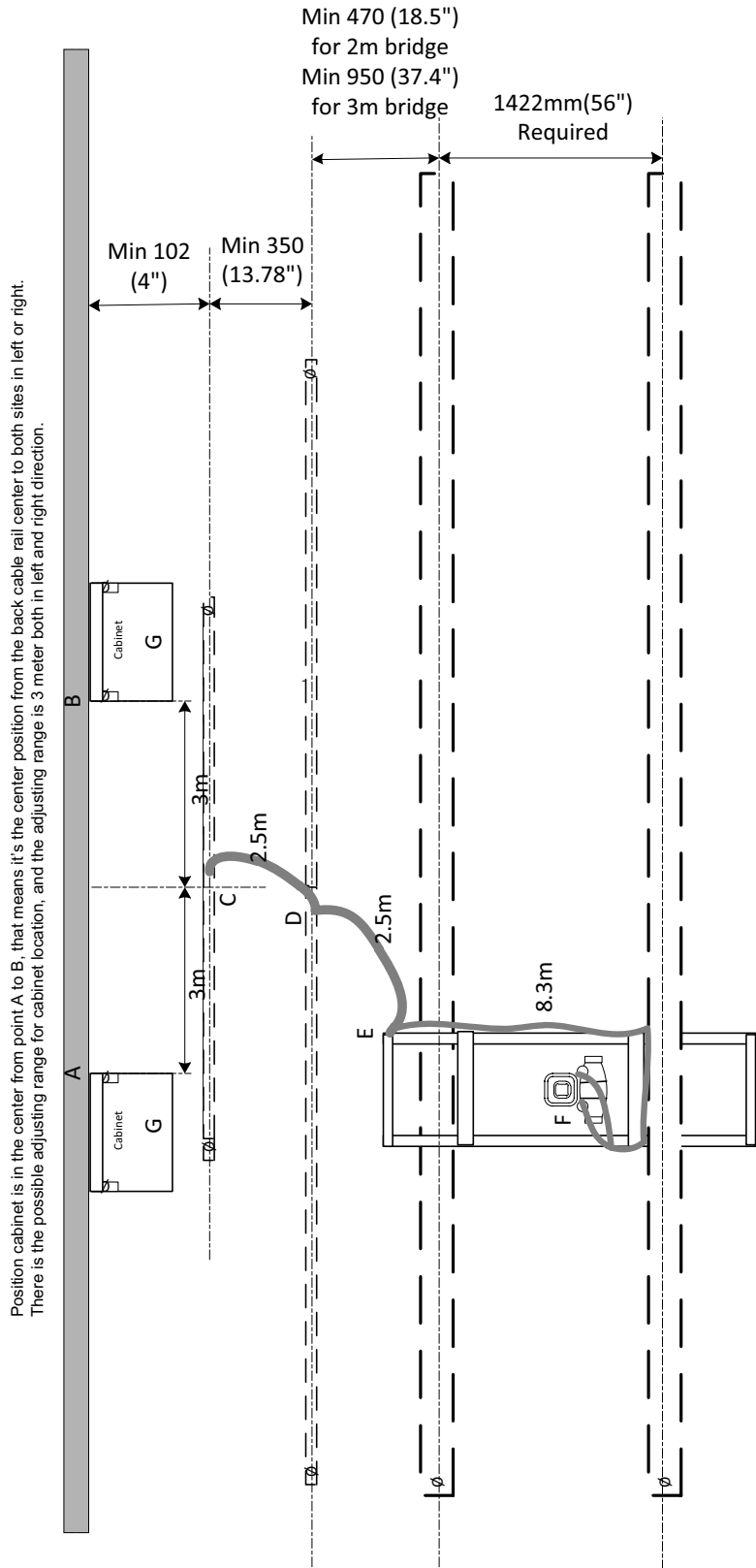

Figure 2-19 12 Meter Rail Cable Routing



2.1.2.4 Wall Requirements

TIB, Detector BIN and AP should be installed on a suitable wall can afford the ASSY. The parameters of these terms are shown in [Table 2-3 Recommended and Minimum Room Heights \(Floor to Top of Longitudinal Rail\)](#) on page 40.

2.1.2.4.1 Tether Interface Box (TIB)

Provide a wall space to hang the TIB in the exam room, see [Figure 2-20 TIB structure overview on page 54](#) and [Figure 2-21 TIB rear cover \(wall mount\) on page 55](#). Expanding plastic sleeves are provided for the wall screws which are designed to expand into the drywall.

NOTE

1. The stuff of wall is concrete and the thickness is more than 80mm, drill two 12mm diameter holes 50 mm deep with masonry drill, fix the anchor in the holes, the height between the bottom of the TIB and the floor is no more than 70cm, mount the TIB on the wall.
2. Tightening torque for preload 20Nm
3. Thread locker: Loctite 243.
4. Add painted mark on anchor heads

Figure 2-20 TIB structure overview

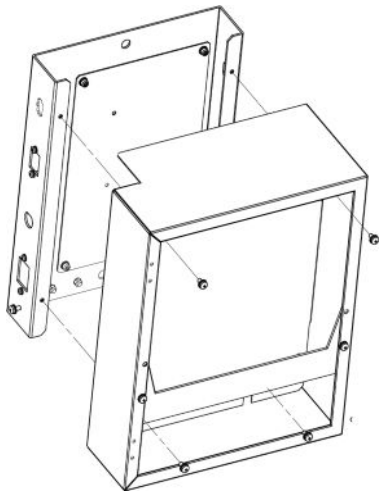

Figure 2-21 TIB rear cover (wall mount)

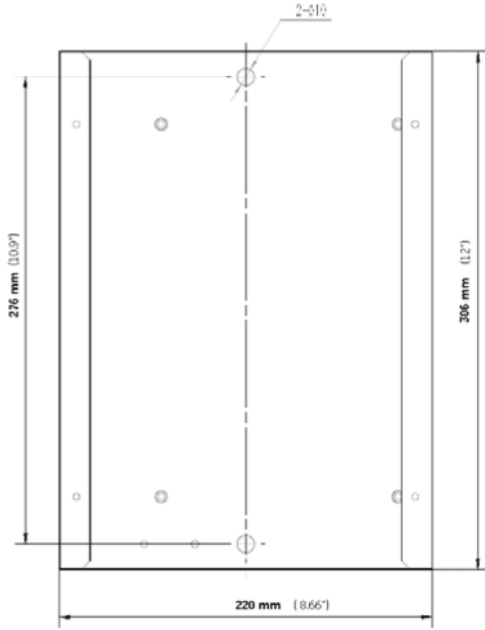

Plate Thickness 2mm

2.1.2.4.2 Detector BIN

Wall mounting



NOTE

Detector BIN should be installed < or = 300mm (11.8in) height from the Detector Bin bottom to the floor.

Figure 2-22 Detector Bin wall mounting

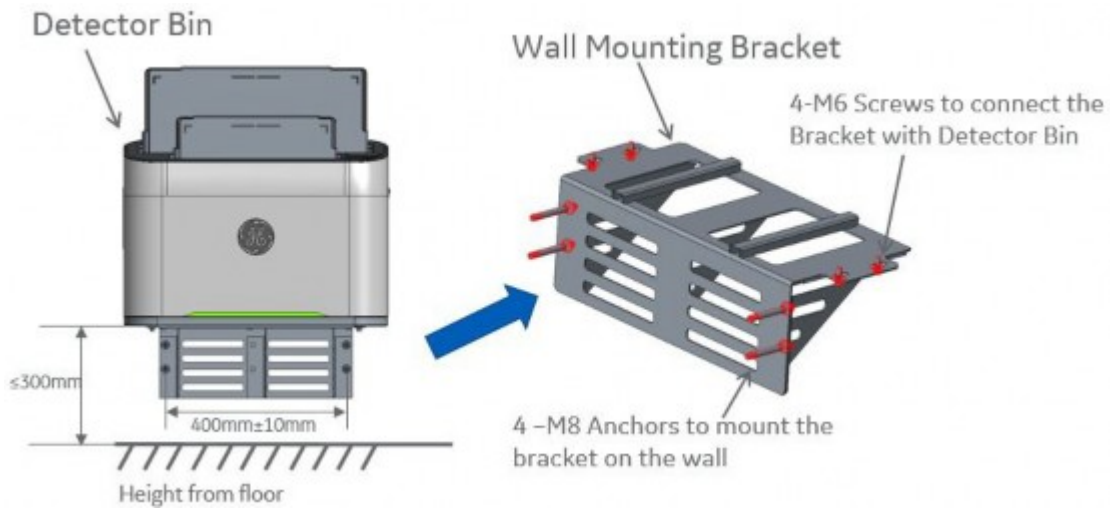

**NOTE**

1. if the stuff of wall is concrete and the thickness is more than 80mm, drill four 12mm diameter holes 50 mm deep with masonry drill, fix the anchor in the holes firstly, the recommended height between the bottom of the Detector bin and the floor is no more than 30cm, mount the bin on the wall; or else, mount the bin on the floor.
2. Tightening torque for preload: a) Anchor heads, 20Nm; b) M6 Screws, 8 Nm.
3. Thread locker: Loctite 243.
4. Add painted mark on 4 anchor heads and 4-M6 screws

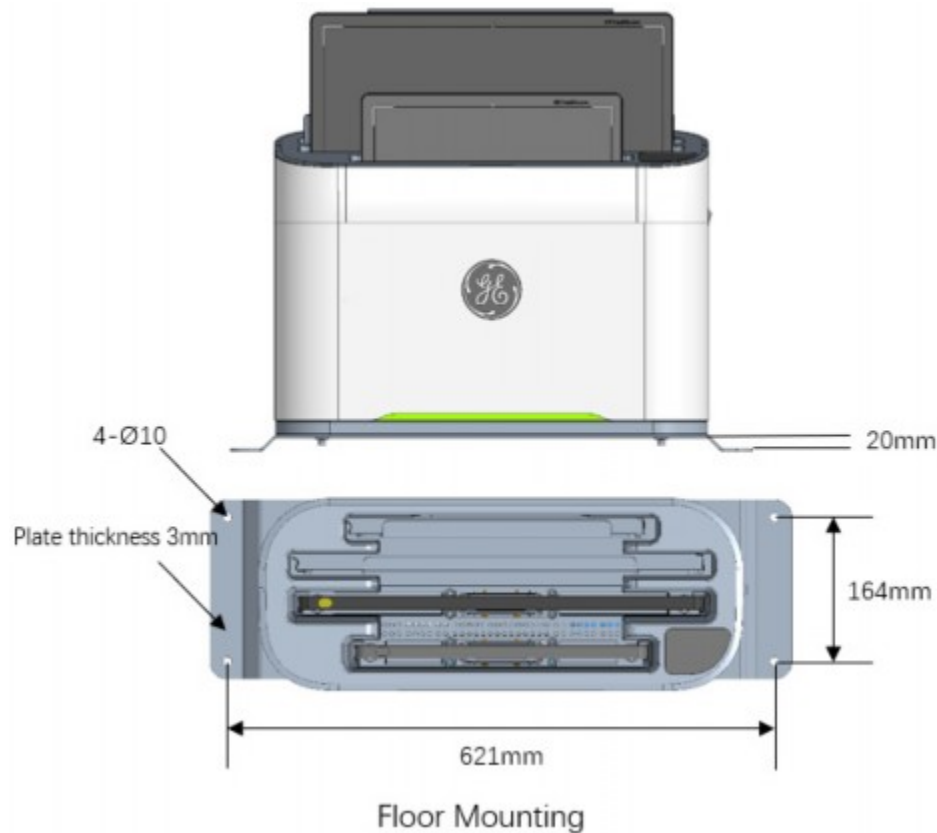
Floor mounting**Figure 2-23 Detector Bin Floor Mounting****2.1.2.4.3 AP Wall-mounting Position**

Refer to below pictures to find out the AP position. There are 6 different positions is available to AP wall-mounting.

Figure 2-24 AP Wall-mounting position

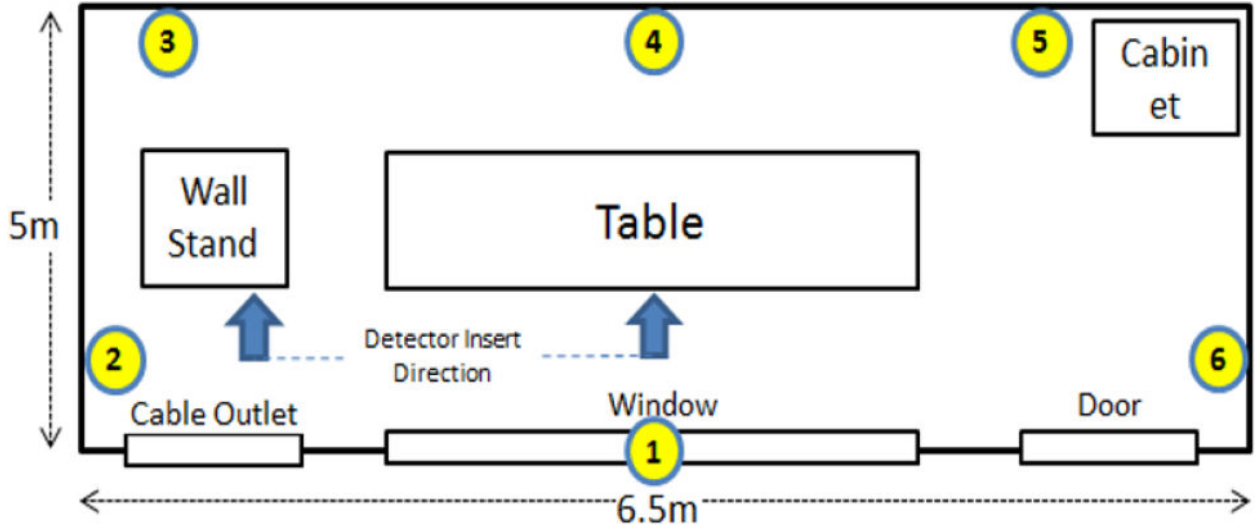

NOTE

Wall Mounted: 2.5m Height to avoid potential blocking from human or other obstacles, use the image below as template for mounting AP Wall Mount Kit.

Figure 2-25 All mounting holes have a 4 mm diameter

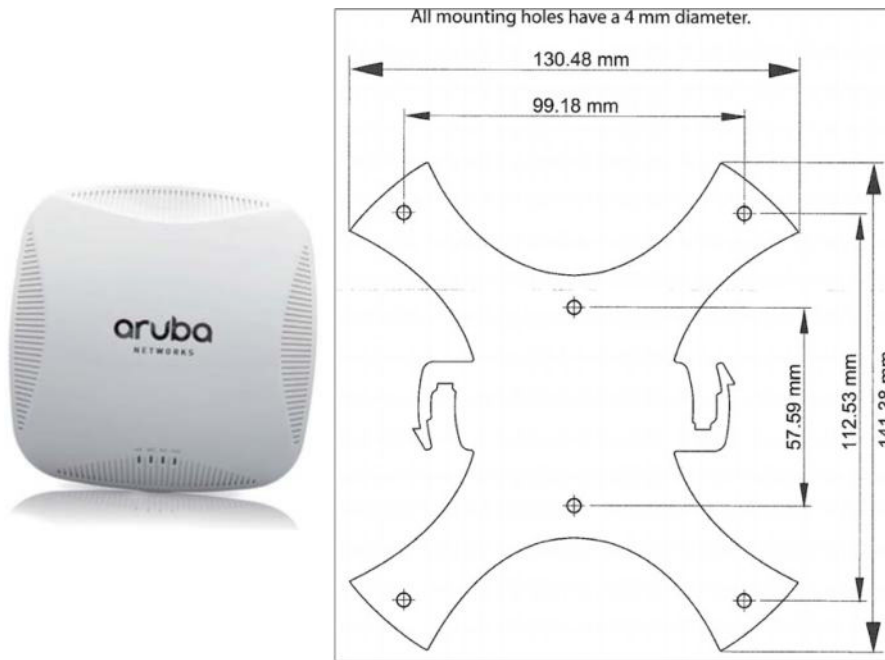

NOTE

AP is only be provided for wireless system. That is not including in Non Wireless Configuration system.

2.1.2.4.4 Grid Holder

NOTE

1. The stuff of wall is concrete and the thickness is more than 80mm, drill four 12mm diameter holes 50 mm deep with masonry drill, fix the anchor in the holes firstly, the recommended height between the bottom of the Grid box and the floor is no more than 30cm, mount the Grid box on the wall, or else, mount the bin on the floor.
2. Tightening torque for preload: a) Anchor heads, 20Nm; b) M6 Screws, 8Nm.
3. Thread locker: Loctite 243.
4. Add painted mark on 4 anchor heads and 4-M6 screws.

Figure 2-26 Grid Holder overview and Grid Holder Wall Panel

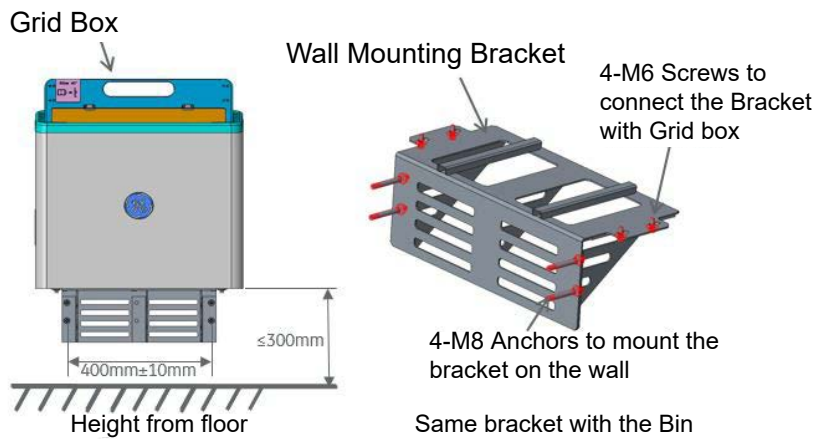

2.1.2.5 Room Light Requirements

The lighting of the room should ensure patient exposure use and GE HealthCare normal service. Depend on different applicable scenery, highly recommended provide different room light source, as [Table 2-5](#).

Table 2-5

Light Source	Illuminance (lux/lx)	Recommended Equivalent (W)	Applicable scenery
LED lamp	75-350	15-60	Patient exposure
Fluorescent lamp		30-90	
LED lamp	350-800	60-150	GE HealthCare service
Fluorescent lamp		90-300	

NOTE

1. Spotlights are not suggested to be installed in exam room, it may interfere with infrared components in the system.
2. Suggest adding the Anti-IR coating to fluorescent lamp. The anti-IR coating should be able to filter IR signal with 940nm wavelength. Otherwise, it's possible to lead to the IR controller cannot work normally sometimes.

For the electronic ballast of fluorescent lamp in exam room, the operating frequency should be above 42KHz, For reference:

Priority	Manufacture	Type		Manufactory Product number	Operating frequency	Remarks
1	OSRAM	T5	QTi2X35/49/80	4008321174291	45...70KHZ	Except QTIS e 3x36/220-240CW
		T8	QTIS e series, For example: QTIS e 1x18/220-240	4050300775388		
2	Philips	T5	HF-P III TL5 series: HF-P 149 TL5 HO III HF-P 149 TL5 HO III HF-P 114-35 TL5 HE III HF-P 114-35 TL5 HE III	913713028066 913713028166 913713031066 913713031166	46KH	
		T8	HF-P III TLD series: HF-P118TL-D III HF-P218TL-D III HF-P136TL-D III HF-P236TL-D III HF-P158TL-D III HF-P258TL-D III	913713031266 913713031366 913713031566 913713031666 913713031866 913713031966	45KH	
3	GE HealthCare	T8	Resi-Proline T8: GE232-120-RES/432-120-RES	97782 97783	Above 42KHz	
			Multi-Volt proline T8 GE-132-MV-N/GE-159-MV-N	30189/95		

2.1.2.6 Exam Room Size

In normal circumstances, the size of the exam room at least to meet the following requirements

Figure 2-27

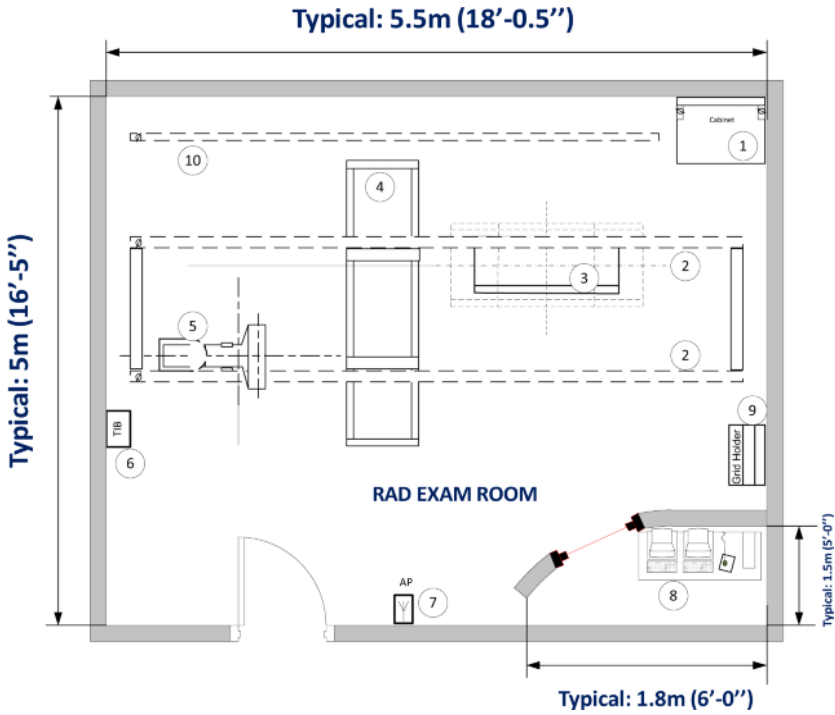

Table 2-6 Exam Room Size

No	Description
1	System Cabinet
2	Longitudinal Stationary Rails
3	Table + Detector
4	OTS & Bridge
5	Wallstand + Detector
6	Tether Interface Box
7	Access Point
8	Magic PC & Monitors
9	Grid Holder
10	Cable Rail

2.2 System Component Dimensions and Weights

2.2.1 Dimensions

Table 2-7 Product Physical Characteristics (Width / Depth / Height)

PRODUCT OR COMPONENT	Model NO	DIMENSIONS			References
		Width	Depth	Height	
Operator Console: PC HP z440 PC HP G4Z4 Monitor RCIM2		168mm (6.6in) 168 mm (6.6 in.) 575mm (23in) 451mm (17.8in)	445mm (17.5in) 445 mm (17.5 in.) 245mm (9.6in) 135mm (5.3in)	432mm (17in) 390 mm (15.4 in.) 510mm (20in) 70mm (2.8in)	
Global G3 Table Assembly	GCTBL-C3 GCTBL-C33	2400mm (94.49in)	933mm (36.73in)	500 - 850mm (19.69 - 33.46in)	See Figure 2-29 Table Views on page 65
Global G3 Table Table Top Movement Dimension	GCTBL-C3 GCTBL-C33	680mm±10mm (26.77in±0.39in)	280mm±10mm (11.02in±0.39in)	NA	See Figure 2-30 Table Top Movement Dimensions on page 66
G3 Standard Table Table Top Assembly	GCTBL-C5	2330mm (91.7in)	838mm (33in)	525 - 825mm (20.7 - 32.5in)	See Figure 2-31 Table View on page 66
G3 Standard Table Table Top Movement Dimension	GCTBL-C5	990mm±10mm (38.9in±0.39in)	220mm±10mm (8.6in±0.39in)	NA	See Figure 2-32 Table Top Movement Dimension on page 67
Stretchers (optional): Radiographic Stretcher Carbon Fiber Stretcher GST-2 Stretcher		2188mm (86in) 2200mm (86.6in) 2004mm (79in)	917mm (36in) 650mm (25.5in) 640mm (25in)	750mm (30in) 700mm (27.5in) 696mm (27in)	See Figure 2-47 Radiographic stretcher dimensions on page 78 See Figure 2-48 S1700JM Carbon Fiber Stretcher Dimensions (optional) on page 78 See Figure 2-49 GST-2 Stretcher Dimensions (optional) on page 78
Stationary Rail (each)		4115~5791mm (13.5~19ft)	62.5mm (2.45in)	84.3mm (3.32in)	See Figure 2-38 OTS Suspension Focal Spot Travel Range - 2M Bridge on page 71
2 Meter Bridge	5500972	2099mm (82.6in)	659mm (26in)	169mm (6.66in)	See Figure 2-39 OTS Suspension Focal Spot Travel Range - 3M Bridge on page 72
3 Meter Bridge	5500971	3077mm (120in)	659mm (26in)	169mm (6.66in)	
Overhead Tube Support (OTS)	5139720	1000mm (39in)	1050mm (41in)	1900mm (75in)	See Figure 2-37 OTS Side view on page 70

Table 2-7 Product Physical Characteristics (Width / Depth / Height) (Table continued)

PRODUCT OR COMPONENT	Model NO	DIMENSIONS			References
		Width	Depth	Height	
System Cabinet	GCC-C3	847mm (33.3in)	662.2mm (26in)	1475mm (58in)	See Figure 2-33 System Cabinet Dimensions (Front, Top, Left) on page 68 and Figure 2-34 System Cabinet Wall-Mount Bracket on page 69
VCP Cabinet	GCC-C4	900mm (35.43in)	600mm (23.62in)	932mm (36.69in)	See Figure 2-35 VCP cabinet side view on page 69
Tether Interface Box	5765910	255mm (10in)	145mm (5.7in)	310mm (12.2in)	See Figure 2-20 TIB structure overview on page 54 and Figure 2-21 TIB rear cover (wall mount) on page 55
Standard Wall Stand	GCWS-C3	686~1266mm (27~49.85in)	1344mm (52.91in)	2628mm (103.46in)	See Figure 2-40 Wall Stand Dimensions (0 and 90 degrees) on page 73 and Figure 2-41 Wall Stand Base Plate Dimensions (M8) on page 74 and Figure 2-43 Wall Stand Base Plate and its Cover Dimensions on page 76
Extended Wall Stand	GCEWS-C3	686~1266mm (27~49.85in)	1668mm (65.67in)	2628mm (103.46in)	See Figure 2-40 Wall Stand Dimensions (0 and 90 degrees) on page 73 and Figure 2-41 Wall Stand Base Plate Dimensions (M8) on page 74 and Figure 2-43 Wall Stand Base Plate and its Cover Dimensions on page 76
Manual WS	GCMWS-C5	686 -1266mm (27 - 49.8in)	1026mm (40.4in)	2628mm (103.46in)	See Figure 2-44 Wall Stand Dimensions on page 76 and Figure 2-45 Wall Stand Base Plate Dimensions on page 77 and Figure 2-46 Wall Stand Base Plate and its Cover Dimensions on page 77
Image Pasting Barrier with Footstool (option)		1110.4mm (43.71in)	656.76mm (25.86in)	2097mm (82.6in)	See Figure 2-50 Image Pasting Barrier Dimensions (Optional) on page 79
Detector BIN	5765692	550mm (21.7in)	220mm (8.6in)	390mm (15.4in)	See Figure 2-22 Detector Bin wall mounting on page 55
AP Assembly	5720157 5861674	140mm (5.5in)	140mm (5.5in)	20mm (0.8in)	See Figure 2-24 AP Wall-mounting position on page 57

Table 2-7 Product Physical Characteristics (Width / Depth / Height) (Table continued)

PRODUCT OR COMPONENT	Model NO	DIMENSIONS			References	
		Width	Depth	Height		
Flash Pad HD Detector	17X17 in	5771717	460mm (18in)	460mm (18in)	16mm (0.6in)	See Figure 2-28 FlashPad Detector on page 63
	14X17 in	5771417	460mm (18in)	384mm (15in)		
	10X12 in	5771012	332mm (13in)	282mm (11in)		
Grid Holder			511.8mm (20.15in)	202.4mm (7.97in)	504.5mm (19.86in)	See Figure 2-26 Grid Holder overview and Grid Holder Wall Panel on page 58
UPS (option)			214mm (8.43in)	410mm (16.14in)	325mm (12.80in)	See Figure 2-51 UPS Dimensions (Optional) on page 80
	7000700-RL1T (9SX700)		160mm (6.3in)	357mm (14.1in)	252mm (9.9in)	

2.2.2 FlashPad HD Detector

Figure 2-28 FlashPad Detector

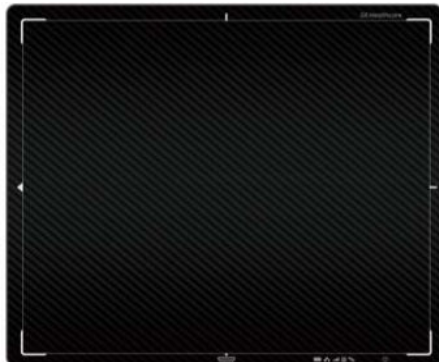

Dimensions:

- 17X17: L 460 mm, H 460 mm, T 16 mm
- 14X17: L 460 mm, H 384 mm, T 16 mm
- 10X12: L 332 mm, H 282 mm, T 16 mm

- Battery or tether operated. Includes two rechargeable and exchangeable batteries and 7 m cable (4 m or 10 m optional) for optimal connectivity and power
- Desktop battery pack charger

1. 5781012-9M, the material # is 152819.



2. 5781417-9M, the material # is 152815.



3. 5781717-9M, the material # is 152820.



4. 5781012-9, the material # is 152810.



5. 5781417-9, the material # is 152814.



6. 5781717-9, the material # is 152821.



2.2.3 Table

Global G3 Table

Figure 2-29 Table Views

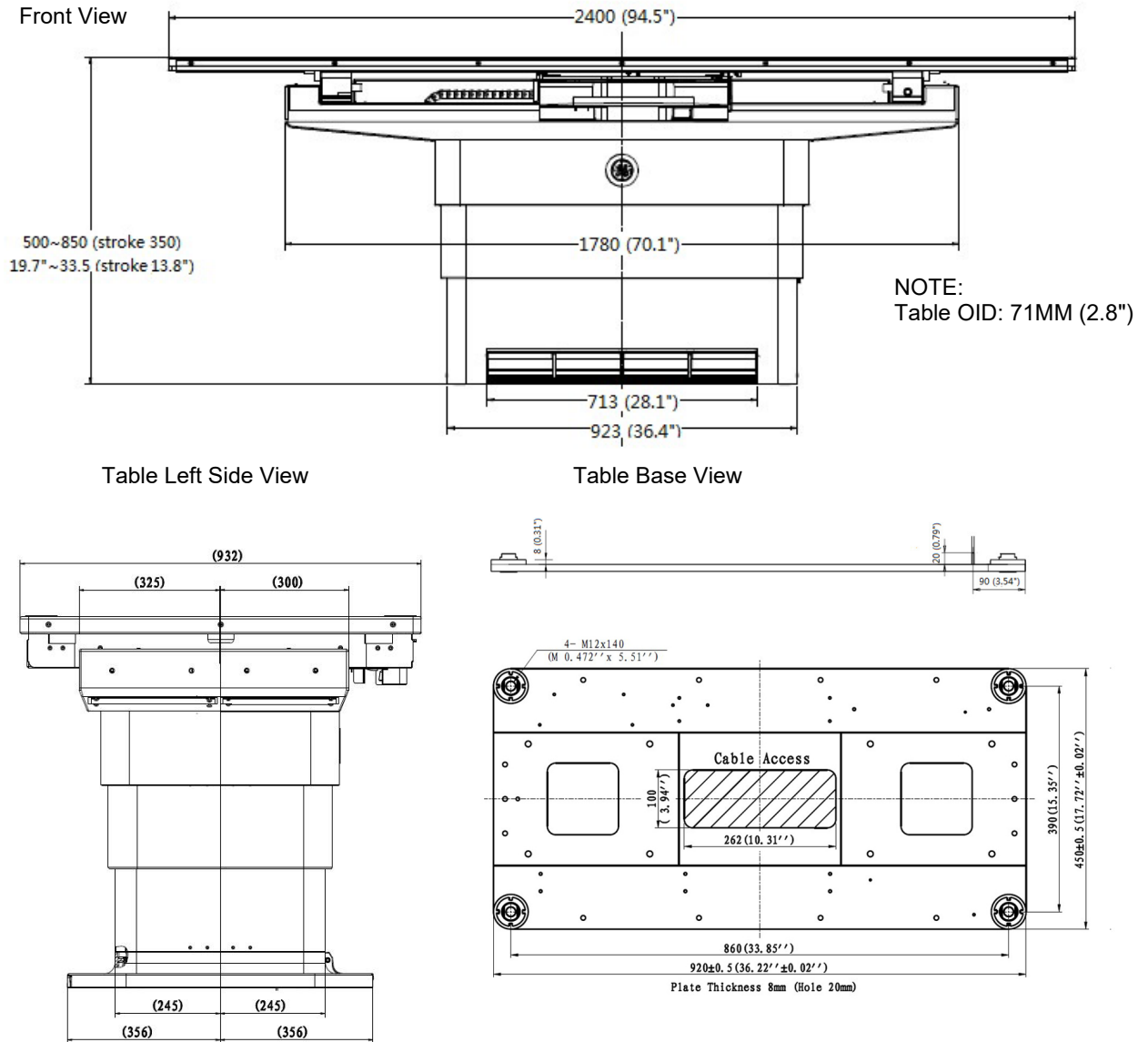
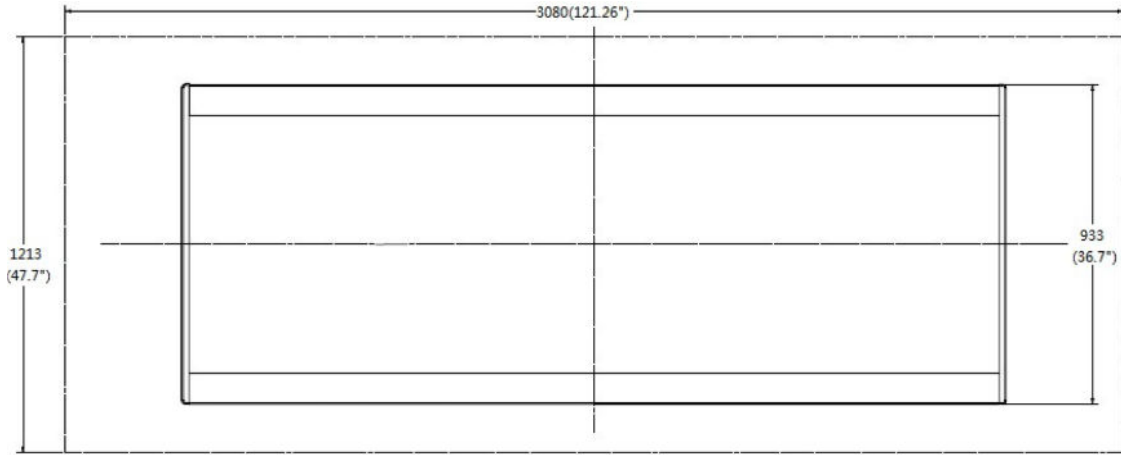
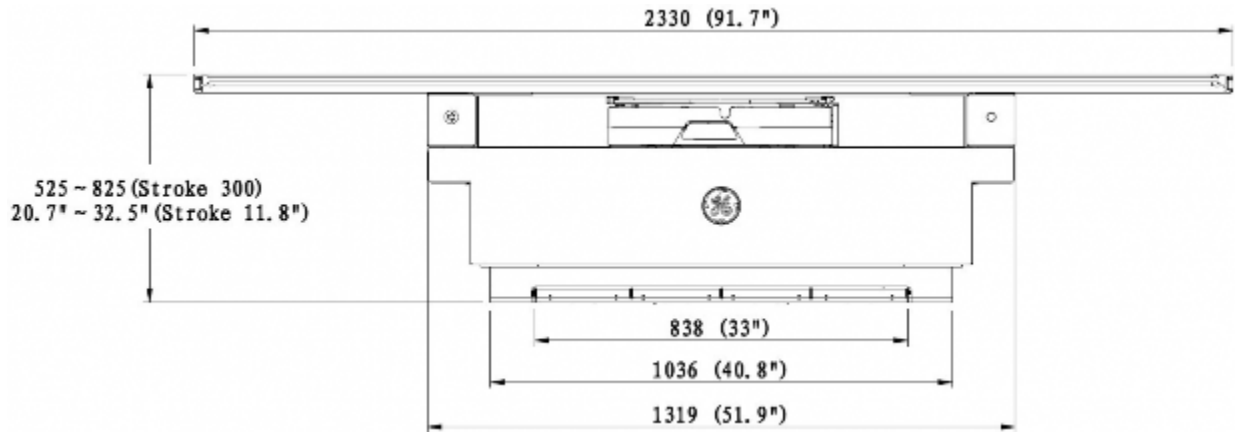

Figure 2-30 Table Top Movement Dimensions



Global G3 Std Table

Figure 2-31 Table View



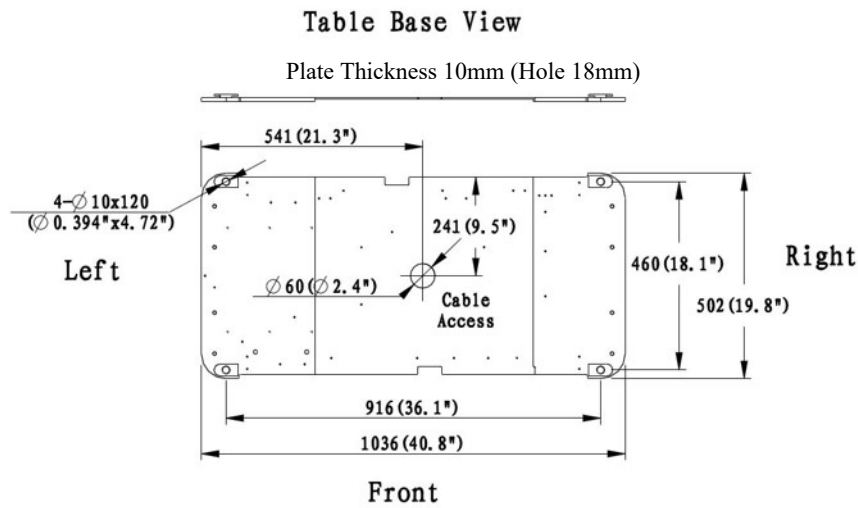
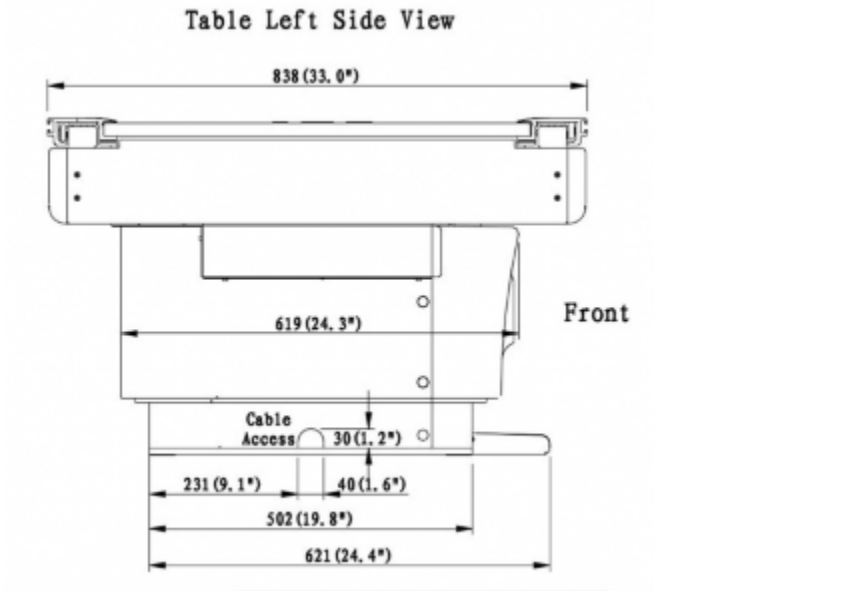
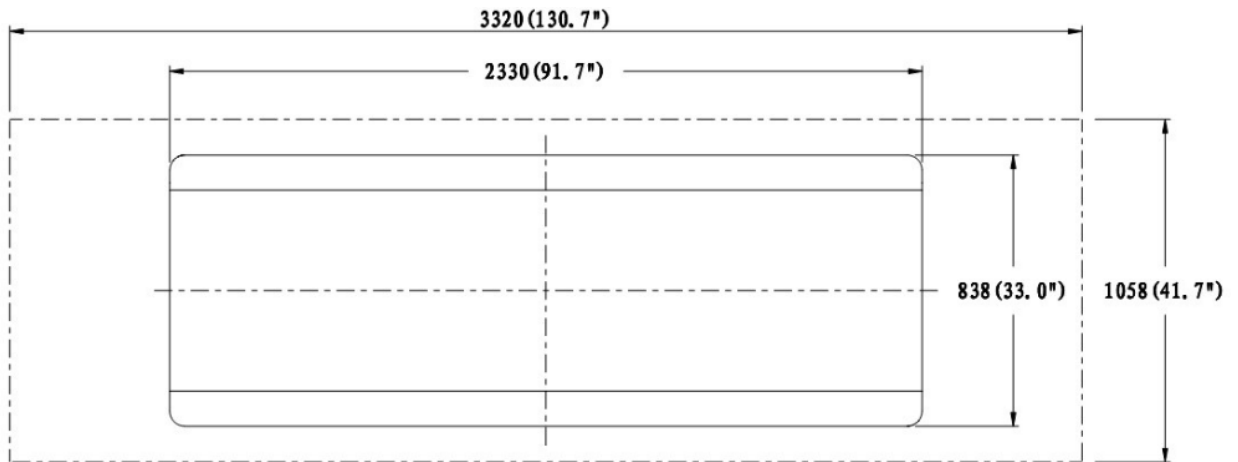

Figure 2-32 Table Top Movement Dimension



2.2.4 System Cabinet

Figure 2-33 System Cabinet Dimensions (Front, Top, Left)

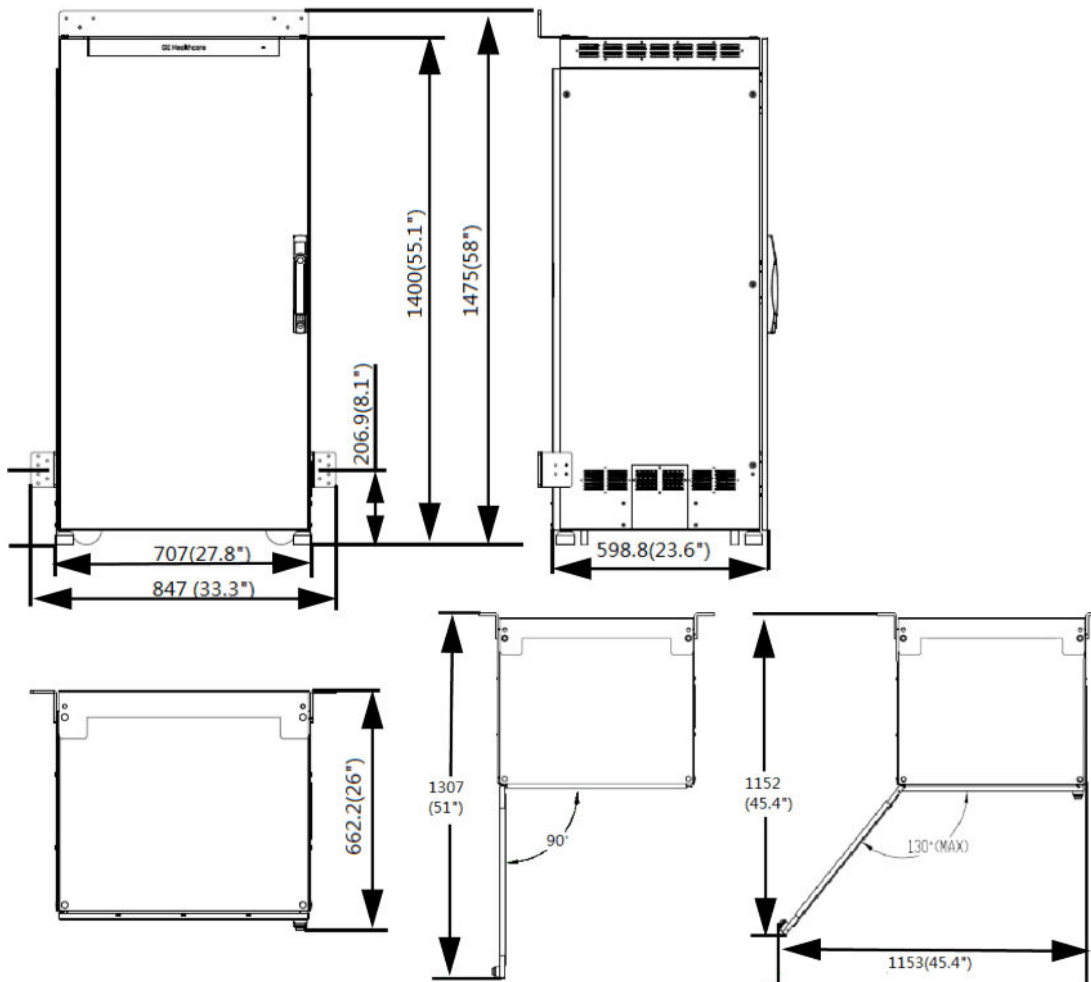
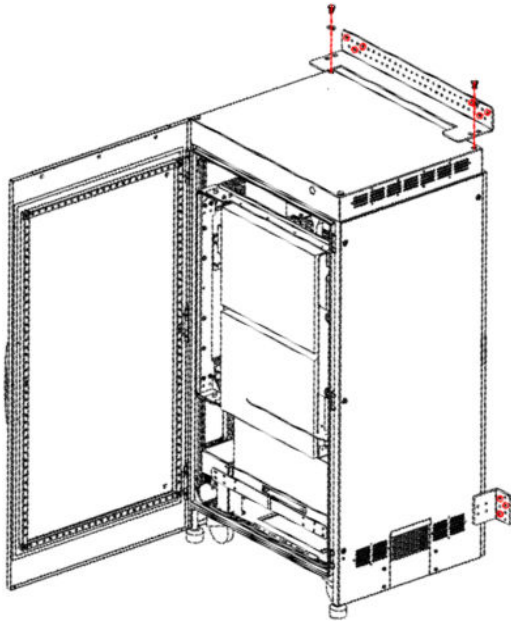

Figure 2-34 System Cabinet Wall-Mount Bracket

Recommended seismic mounting locations (in red circles)



2.2.5 VCP cabinet

Figure 2-35 VCP cabinet side view

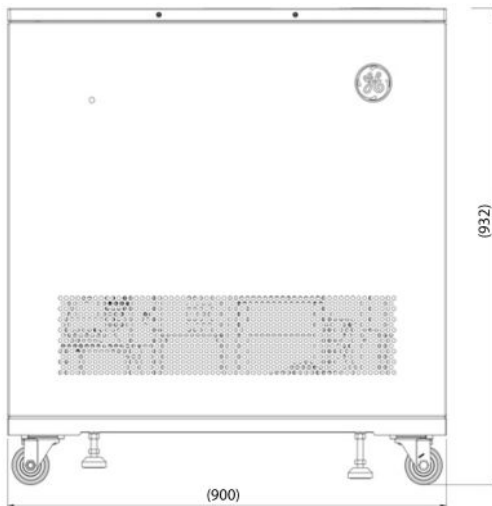
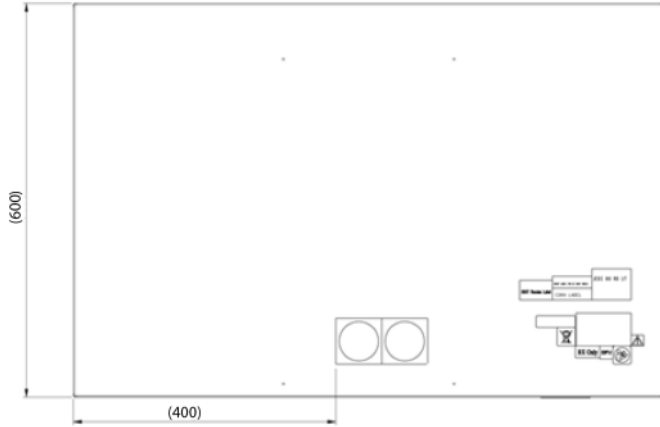

Figure 2-36 VCP cabinet top view



2.2.6 Over-Head Tube Support (OTS)

The OTS comprises a system for suspending and supporting an X-ray tube unit and collimator. It employs a spring counterpoise mechanism to balance these loads. The OTS’s main components are the stationary rails, the bridge and the support column.

- When Lowest point of OTS could touch floor, keep OTS SID=1800mm, Height=901+1800+250=2951mm
- When OTS center is parallel to WS center at lowest position of OTS, OTS SID=1800mm, Height=901+1800+285=2986mm
- When OTS center is parallel to WS center at highest position of WS, keep WS travel range=1500mm, Height=901+1500+285=2686mm

Figure 2-37 OTS Side view

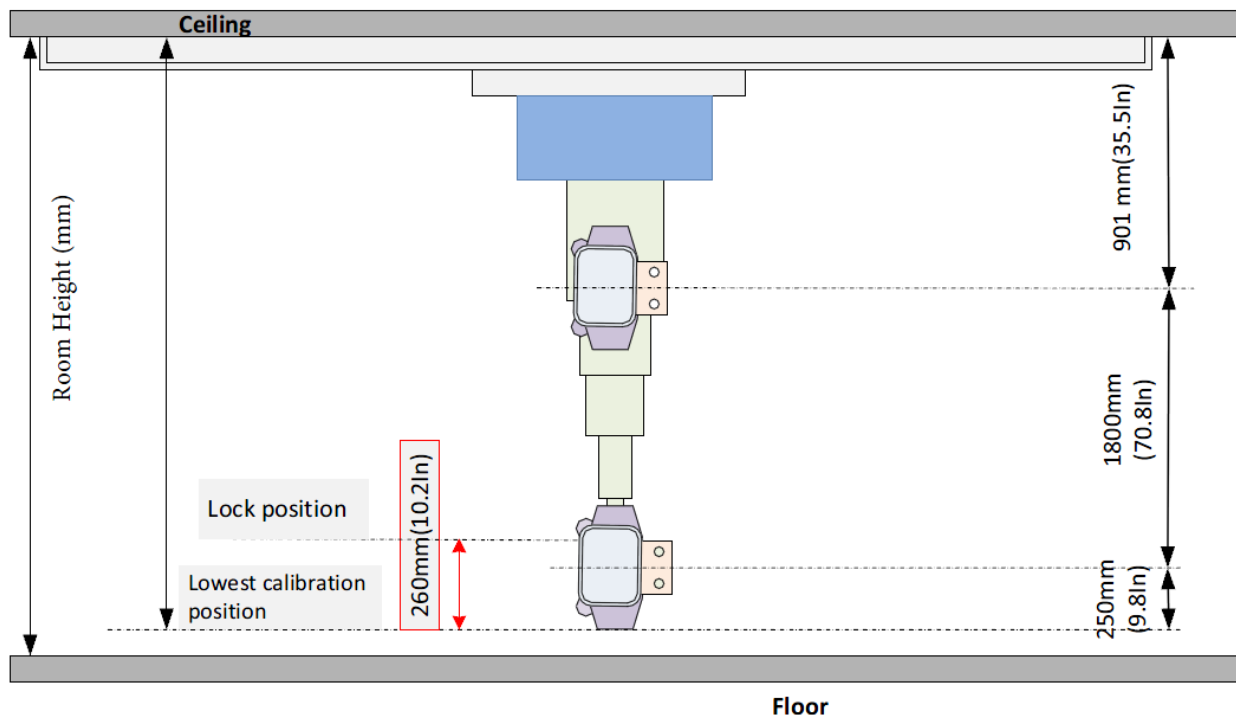

NOTICE

The dimension from bottom of ceiling to bottom of rail is 84.3 mm (3.3 in).

Figure 2-38 OTS Suspension Focal Spot Travel Range - 2M Bridge

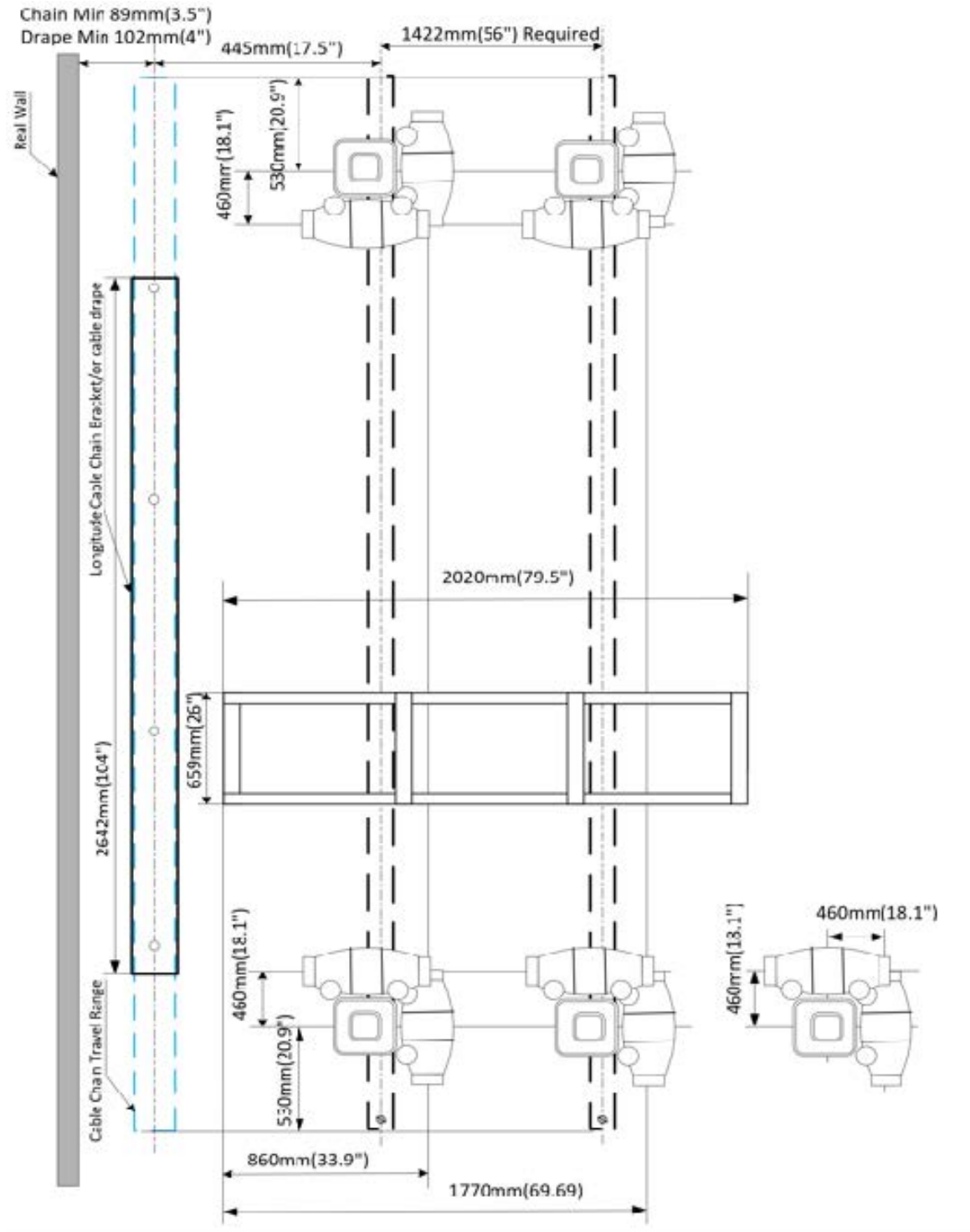
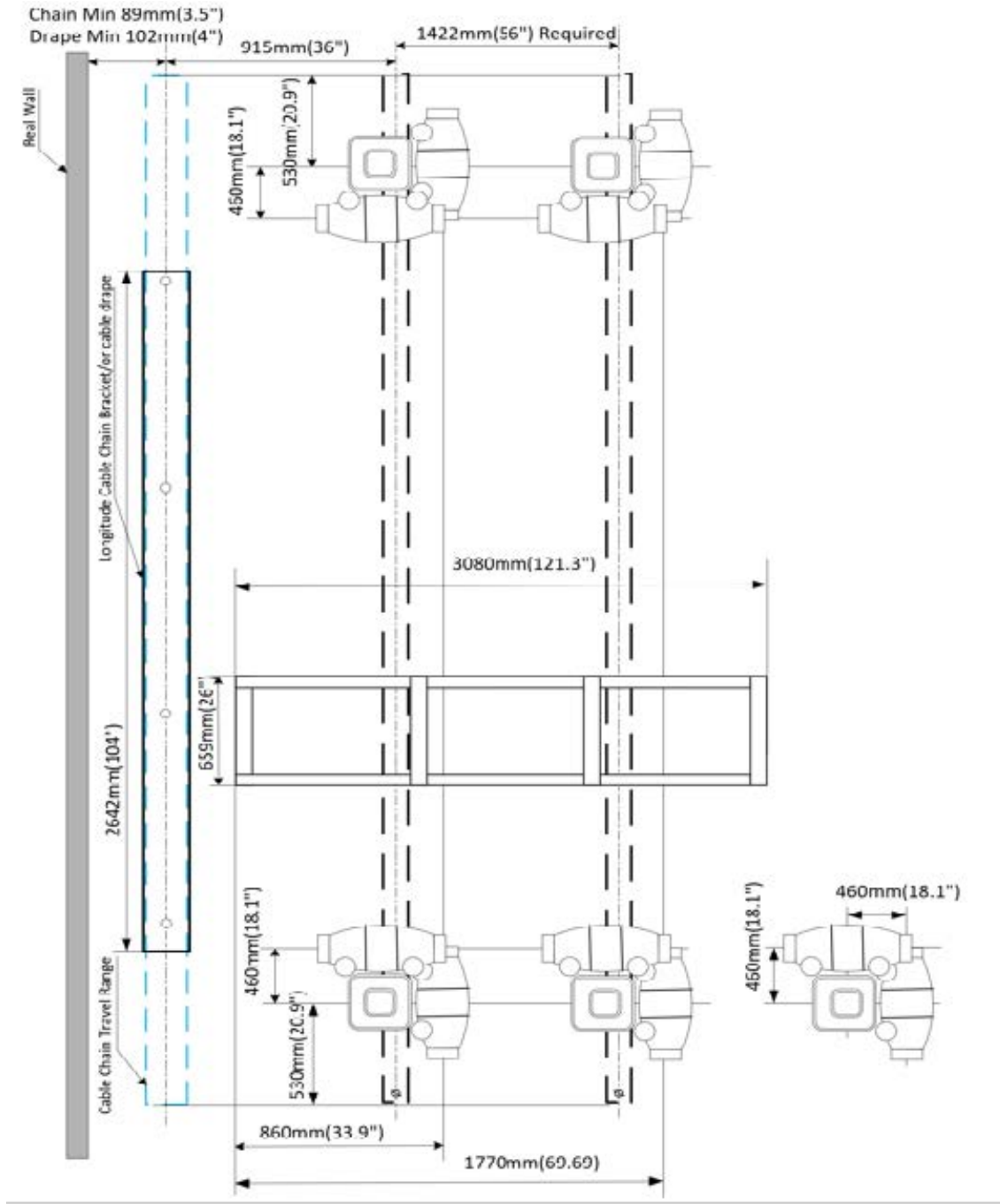

Figure 2-39 OTS Suspension Focal Spot Travel Range - 3M Bridge



2.2.7 Wall Stands

2.2.7.1 Standard WS and Extended WS

Figure 2-40 Wall Stand Dimensions (0 and 90 degrees)

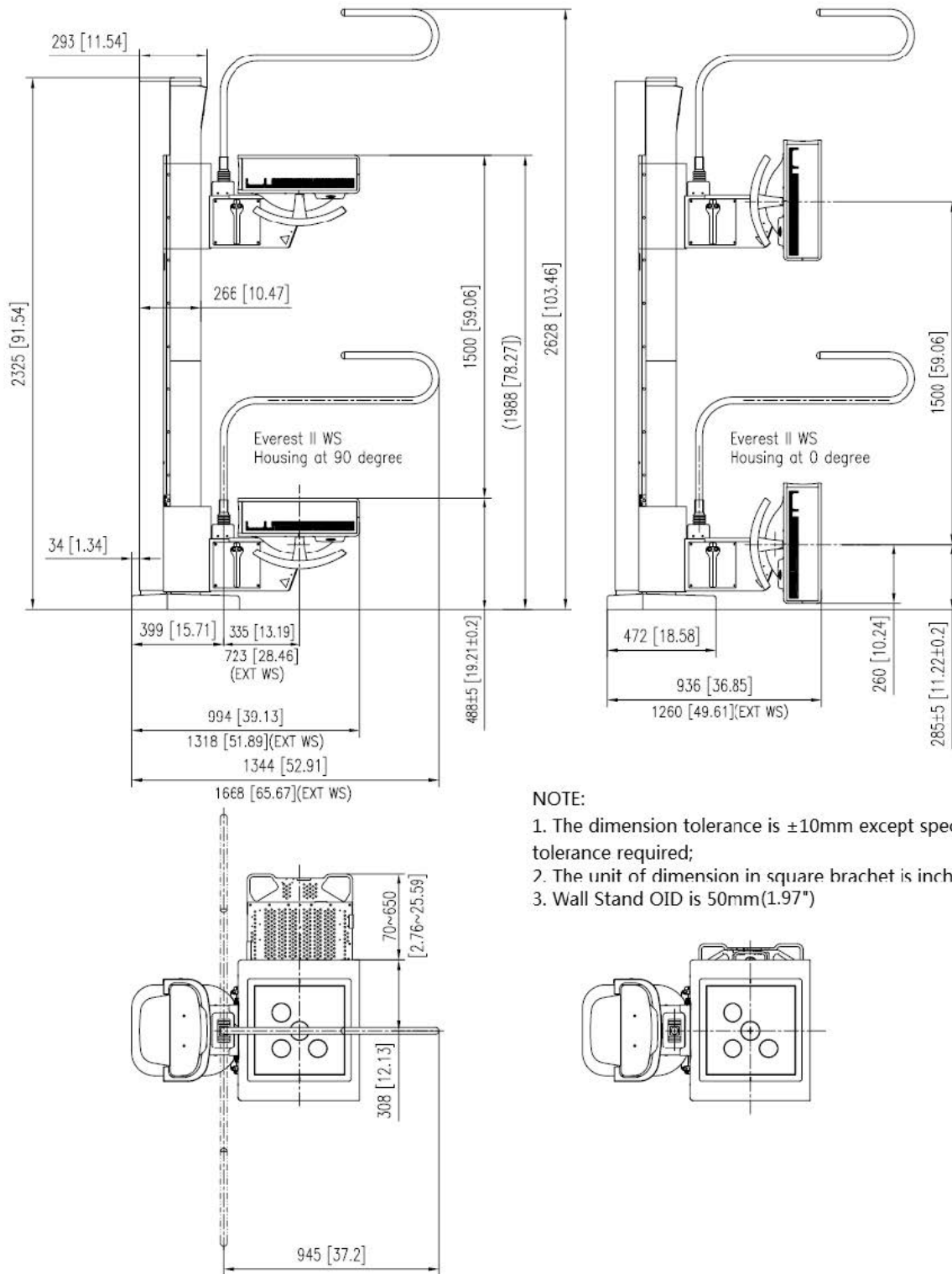

NOTE:

1. The dimension tolerance is ±10mm except special tolerance required;
2. The unit of dimension in square bracket is inch;
3. Wall Stand OID is 50mm(1.97")

Figure 2-41 Wall Stand Base Plate Dimensions (M8)

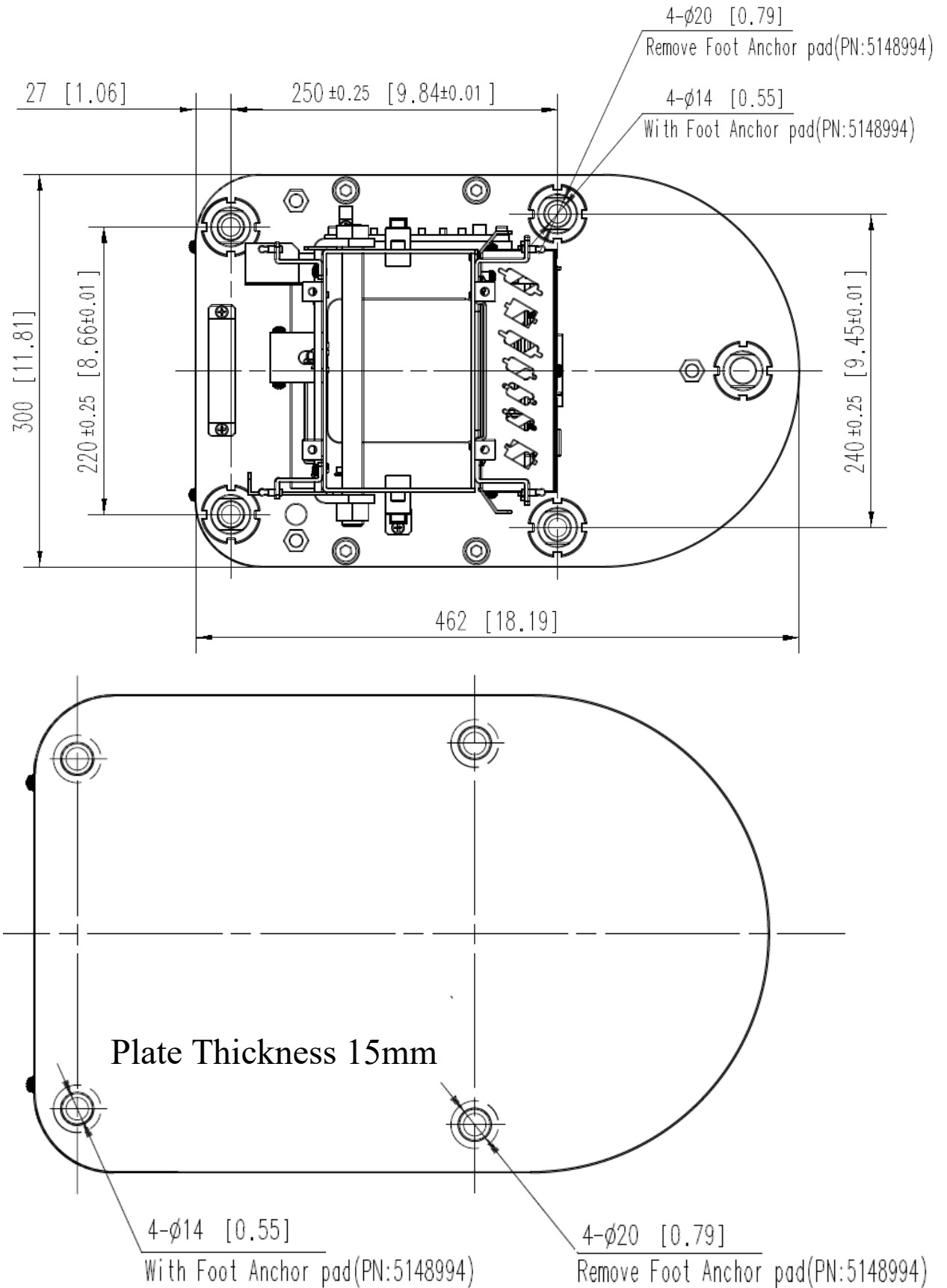

Figure 2-42 Wall Stand Base Plate Dimensions (M12)

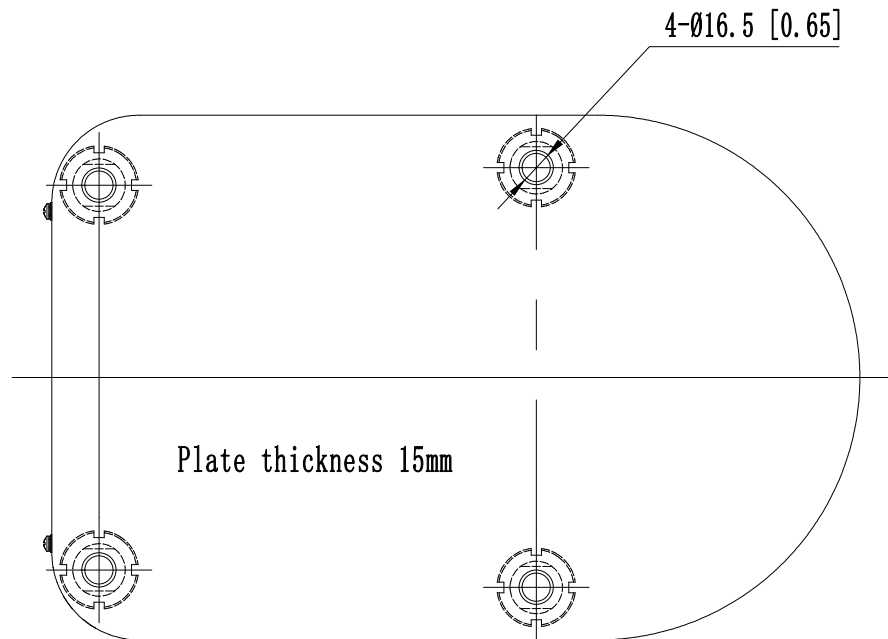
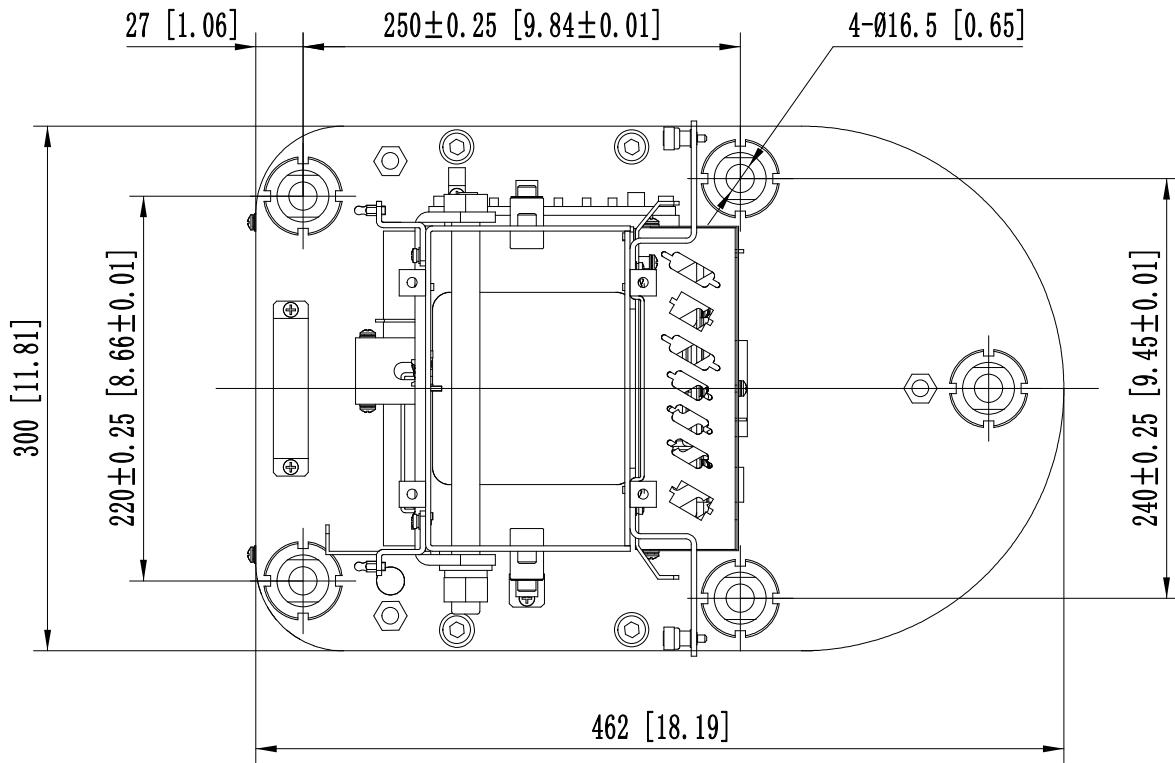
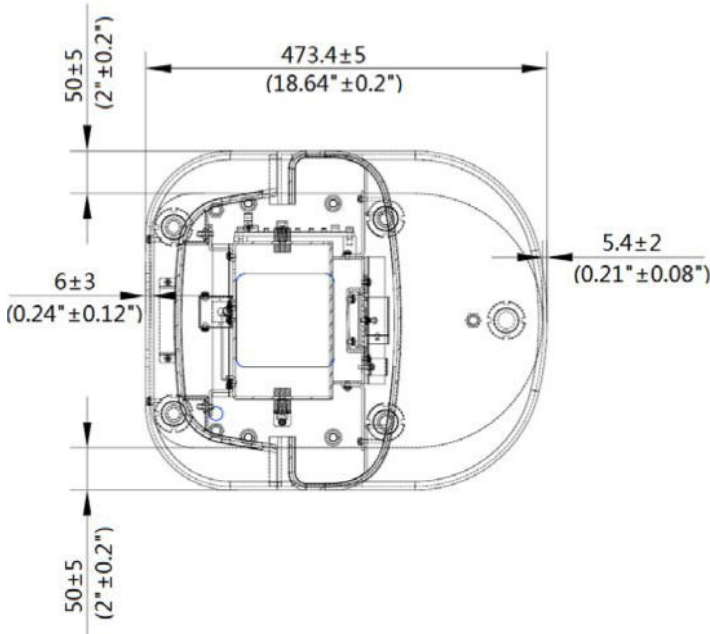

Figure 2-43 Wall Stand Base Plate and its Cover Dimensions



2.2.7.2 Manual WS

Figure 2-44 Wall Stand Dimensions

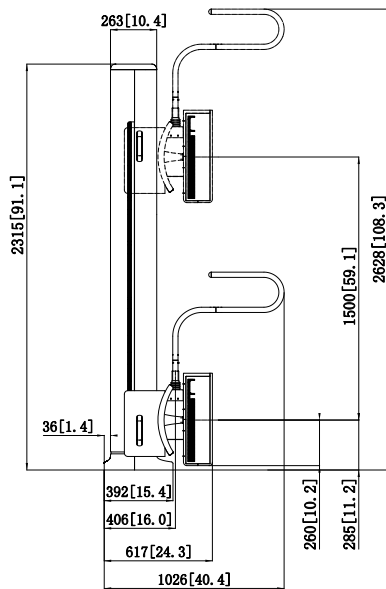

Figure 2-45 Wall Stand Base Plate Dimensions

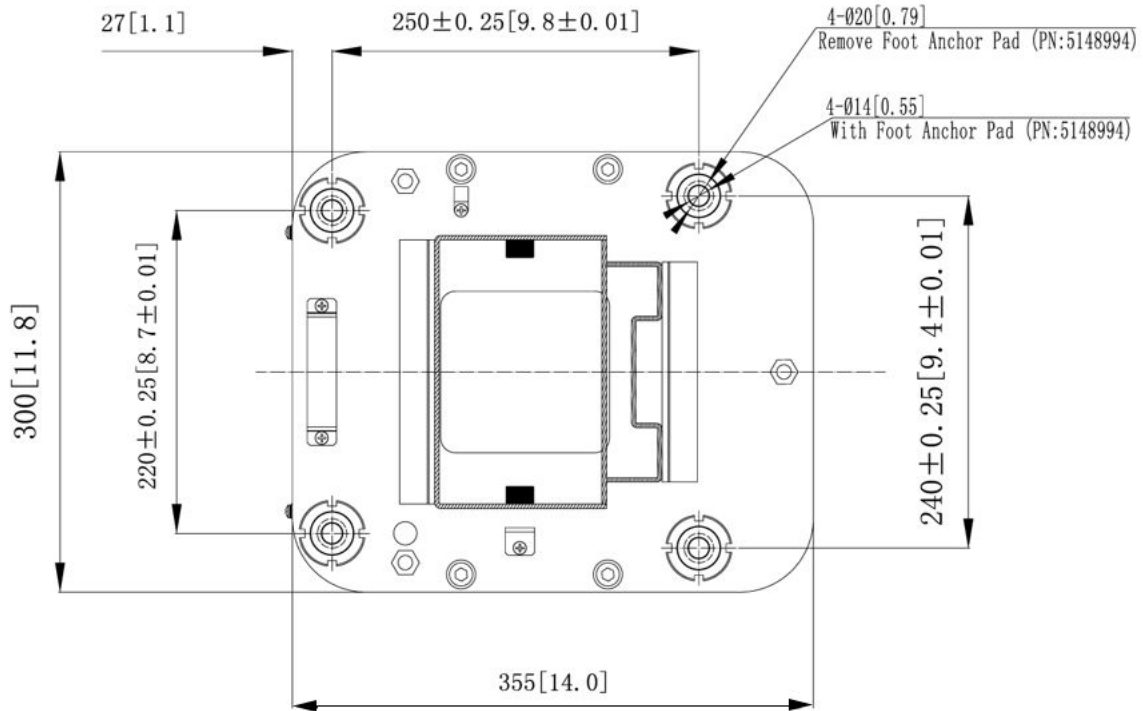
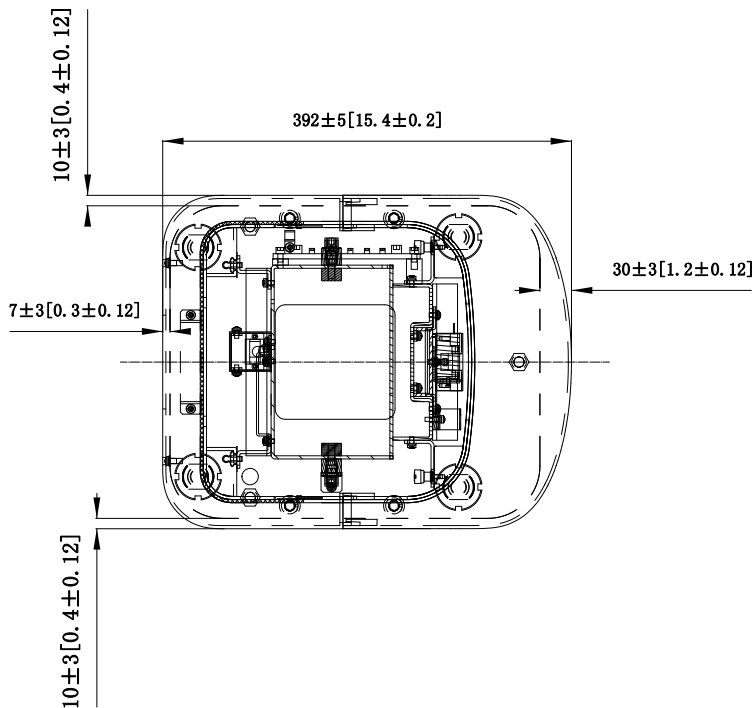

Figure 2-46 Wall Stand Base Plate and its Cover Dimensions



2.2.8 Stretcher Tables

Figure 2-47 Radiographic stretcher dimensions

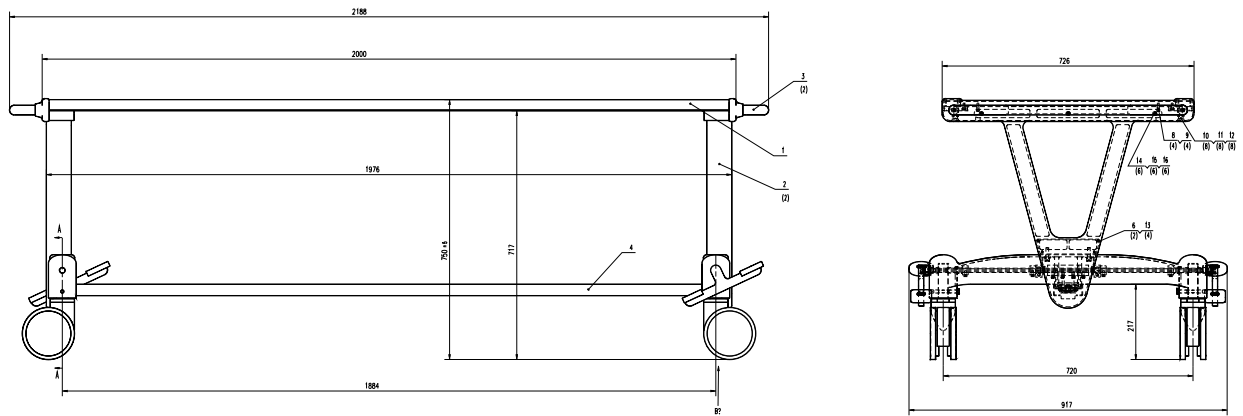

Figure 2-48 S1700JM Carbon Fiber Stretcher Dimensions (optional)

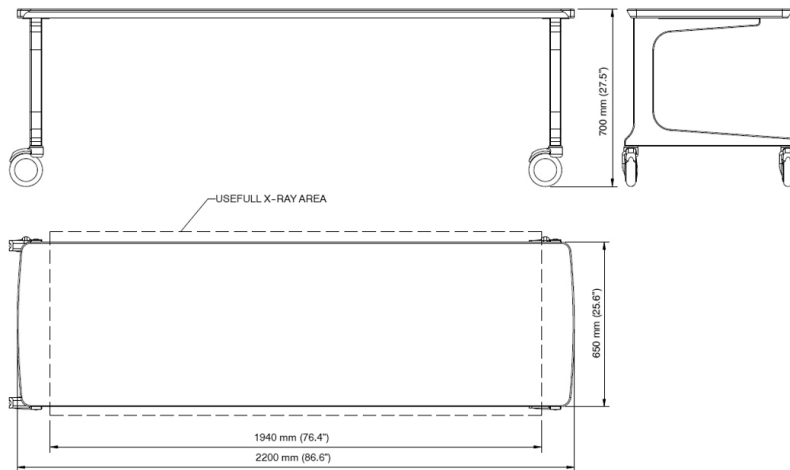
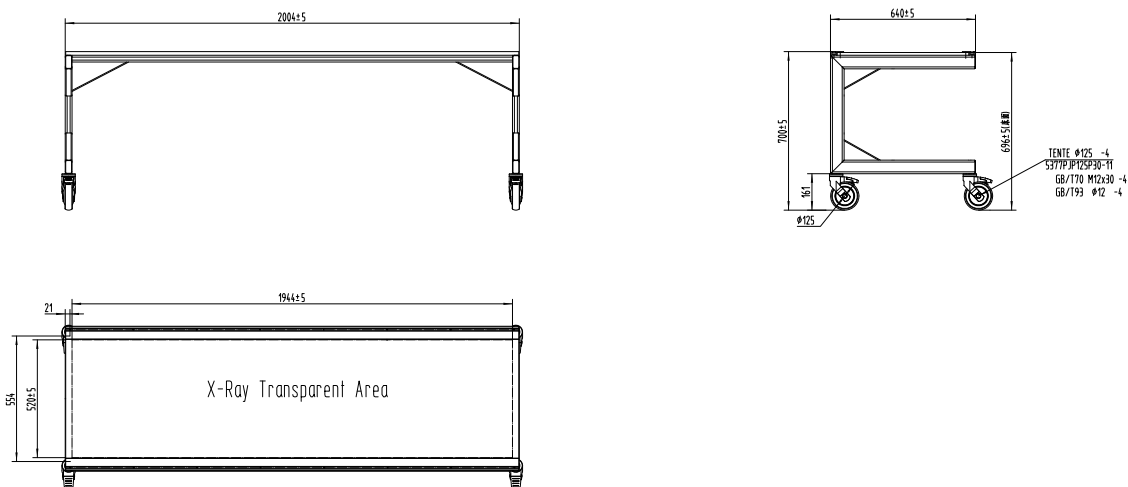
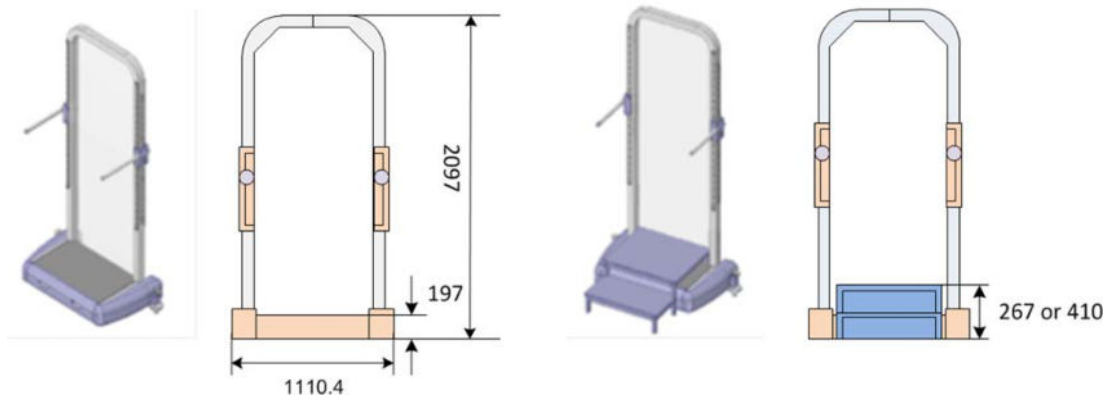

Figure 2-49 GST-2 Stretcher Dimensions (optional)



2.2.9 Image Pasting Barrier

Figure 2-50 Image Pasting Barrier Dimensions (Optional)



2.2.10 UPS

Figure 2-51 UPS Dimensions (Optional)

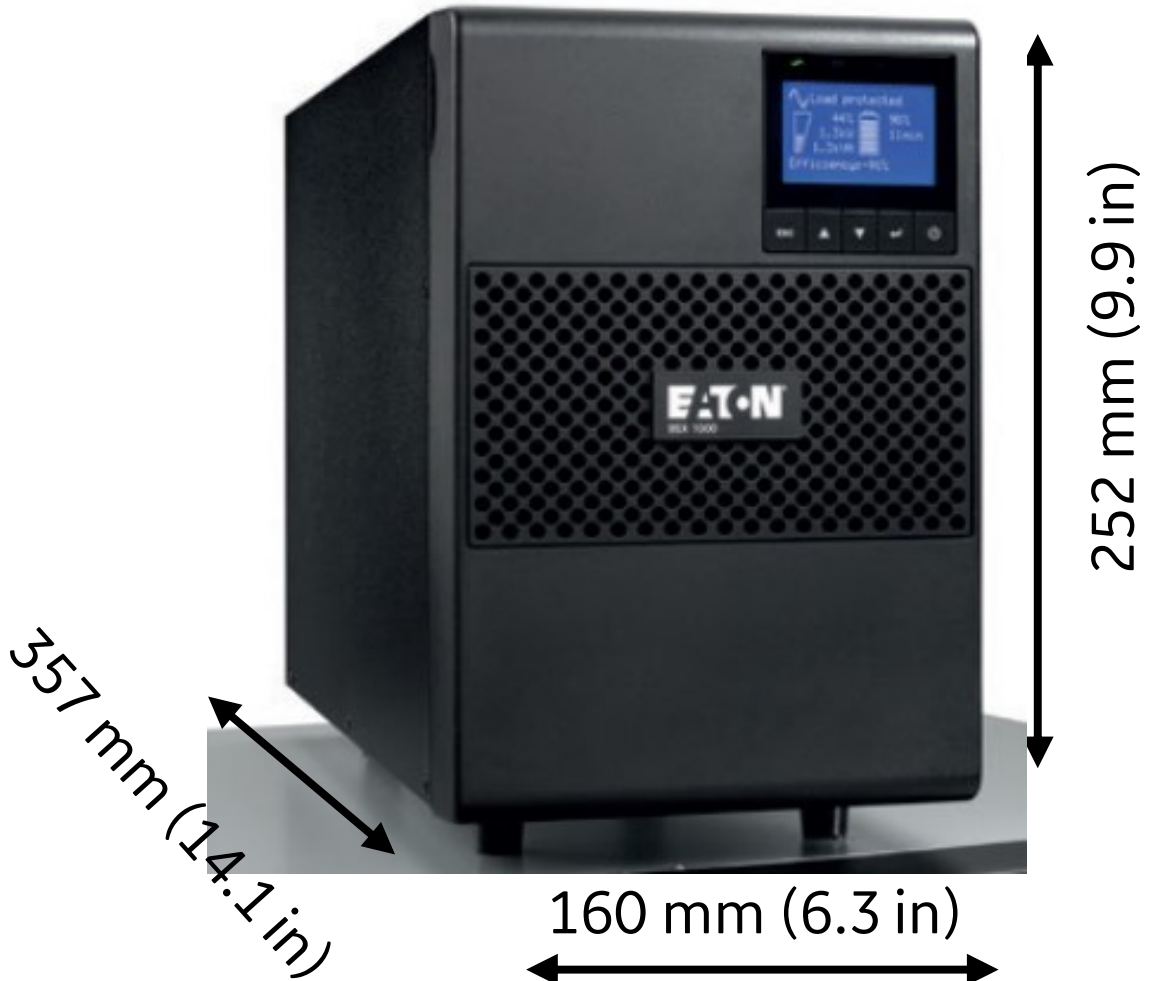

NOTICE

If the UPS grounding impedance exceeds 0.2ohm, UPS will alarm with site wiring fault and this could be disabled through UPS “User Settings”, but not recommended

2.2.11 Weights, Floor/Ceiling Loading and Recommended Mounting Methods

Table 2-8 Product Physical Characteristics (weight)

PRODUCT OR COMPONENT	Model Number	WEIGHT	RECOMMENDED MOUNTING INFORMATION
Operator Console: PC HP z440 PC HP Z4G4 Monitor RCIM		17.5Kg (38.5 lbs) 17.3 Kg (38.14 lbs) 8.2 kg (18.1 lbs) 0.91 Kg (2 lbs)	Shelf or table mounted but not anchored.
Global G3 Table Assembly	GCTBL-C3 GCTBL-C33	380 kg (838 lbs)	Floor mounting Recommendations
Global G3 Table maximum patient weight	GCTBL-C3 GCTBL-C33	320 kg (705 lbs)	NA
G3 Standard Table	GCTBL-C5	320 kg (705 lbs)	Floor mounting Recommendations: (4) M10 X 120 mm anchors (5727758, supplied)
G3 Standard Table maximum	GCTBL-C5	250kg (551lbs)	NA
Stretchers (optional): Non-elevating Non-elevating (carbon fiber)		102 kg (225 lbs) 32 kg (70.5 lb)	Not anchored Not anchored
Standard Wall Stand	GCWS-C3	284 kg (624.4 lbs)	Bossard M10x150L anchors to floor (supplied)
Extended Wall Stand	GCEWS-C3	292kg (642 lbs)	Bossard M10x150L anchors to floor (supplied)
Manual Wall Stand	GCMWS-C5	244kg (537lbs)	
Stationary Rail (5.79 m/228in)	46-316480G24	62.7kg (138lbs)	
OTS	5139720	260kg (573lbs)	
OTS Cable Assembly		56kg (123 lbs)	
OTS Bridge Side Cable Chain Bracket		20kg (44lbs)	
OTS Back Side Cable Chain Bracket		31kg (68lbs)	
Upper OTS Covers		9.5kg (21lbs)	
2 Meter Bridge	5693326	54.9kg (120.8lbs)	
3 Meter Bridge	5693325	63kg (140lbs)	
X-Ray Tube	46-155400G284	29.5 kg (65 lbs)	X-Ray Tube
Collimator	5730663	7kg (15.4 lbs)	

Table 2-8 Product Physical Characteristics (weight) (Table continued)

PRODUCT OR COMPONENT	Model Number	WEIGHT	RECOMMENDED MOUNTING INFORMATION
Stiffener Plate		10.4kg (23lbs)	
UIF		3.2kg (7lbs)	
System Cabinet	GCC-C3	320kg (705lbs)	5/16 in. or 8 mm (6) anchors to floor 5/16 in. or 8 mm (6) anchors to wall (Mounting hardware not provided by GEHC)
VCP cabinet	GCC-C4	198kg (436.5lbs)	
Grid Holder Assembly		13.8 kg (30.42 lbs)	Mount on wall
Image Pasting Barrier with Footstool (option)		54.44 kg (120 lbs)	Floor mounted but not anchored. Located near Wall Stand base.
Detector BIN	5765692	11.8 kg (26lbs)	Floor mounting (not anchored) or wall mount
Tether Interface Box (Optional)	5765910	6 kg (13.4 lbs)	wall mount
AP Assembly	5720157 5861674	0.6 kg (1.3 lbs)	wall mount
Flash Pad HD Detector	5771717	4 kg (8.8 lbs)	
17X17 In	5771417	3.2 kg (7 lbs)	
14X17 In	5771012	1.8 kg (4 lbs)	
10X12 In			
Detector Battery		0.18kg (0.40 lbs)	
UPS (option)		34.5kg (76.06 lbs)	
	7000700-RL1T (9SX700)	11.5 kg (25.4 lbs)	

2.2.12 Longitudinal Rails

Kit B2054LB contains the bumpers and the longitudinal belt.

Table 2-9 Longitudinal Rails S2105JC

Item	Rail Length	Cat Number	Longitudinal focal spot travel
1	4115 mm	B0162JA + B2054LB	3055 mm
2	4420mm	B0174JA + B2054LB	3270 mm
3	4724 mm	B0186JA + B2054LB	3664 mm
4	5030 mm	B0198JA + B2054LB	3880 mm
5	5334 mm	B0210JA + B2054LB	4274 mm
6	5640 mm	B0222JA + B2054LB	4490 mm
7	5791 mm	B0228JA + B2054LB	4731 mm

Figure 2-52 Small distance on the head side

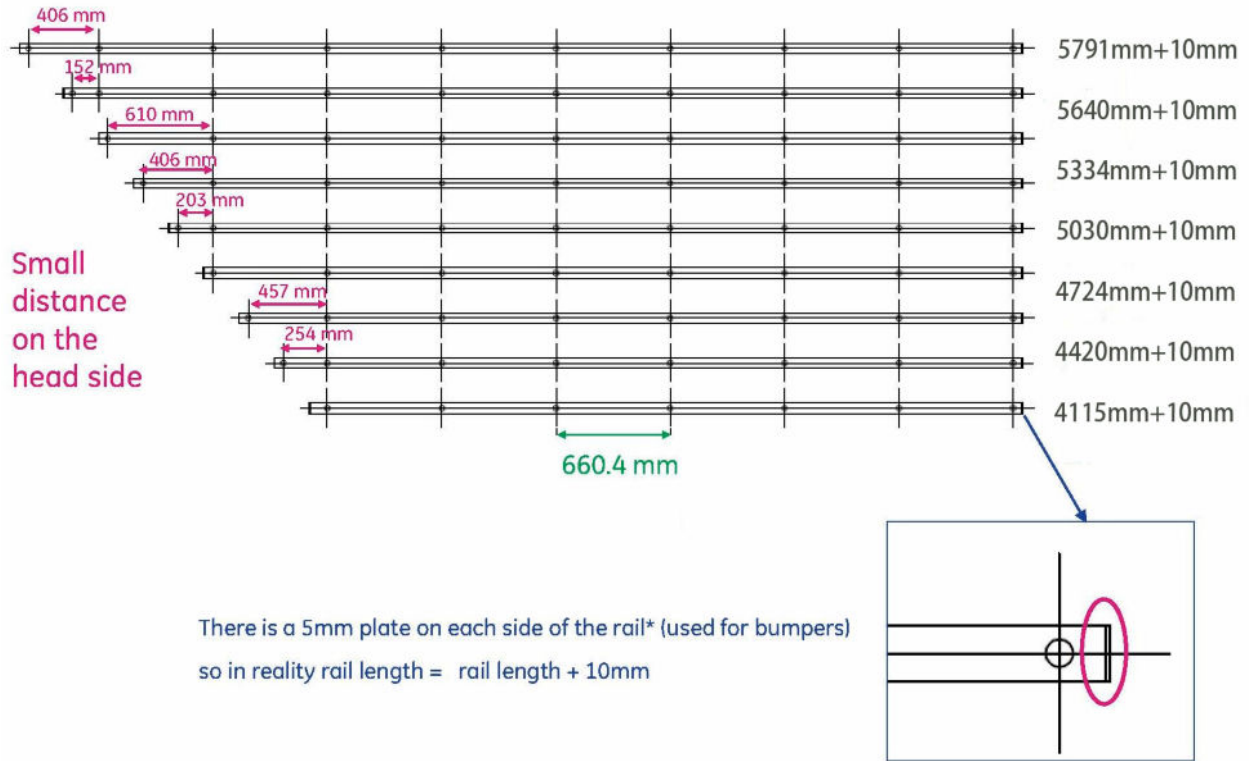

2.3 Room Layout

NOTICE

For **Cabinet location**: Cabinet is recommended to sit at rear side of room, no matter head side or foot side (the cable could routing behind the chain bracket if set cabinet at head site), **if not at rear side**, please **check** whether OTS mis-cable length is enough routing to cabinet from OTS.

(The OTS MIS-cable is 11.5m length from chain bracket cable entrance to the end.)

2.3.1 Required Service Access Clearance

Allow appropriate space for service access of equipment. Illustrations are shown below indicating the required access space for servicing the equipment.



NOTE

The right side space for service can be moved to the left side also.

Figure 2-53 System Cabinet

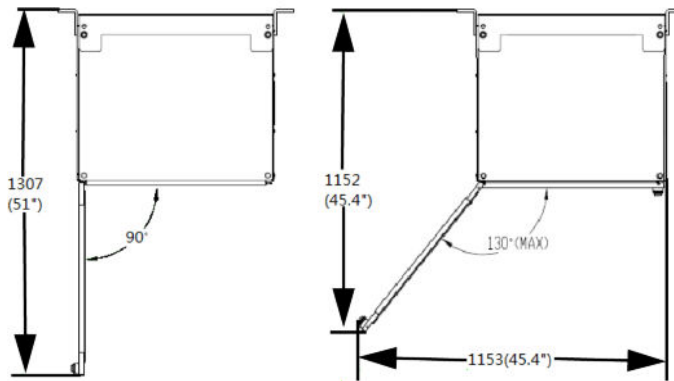

Figure 2-54 VCP cabinet

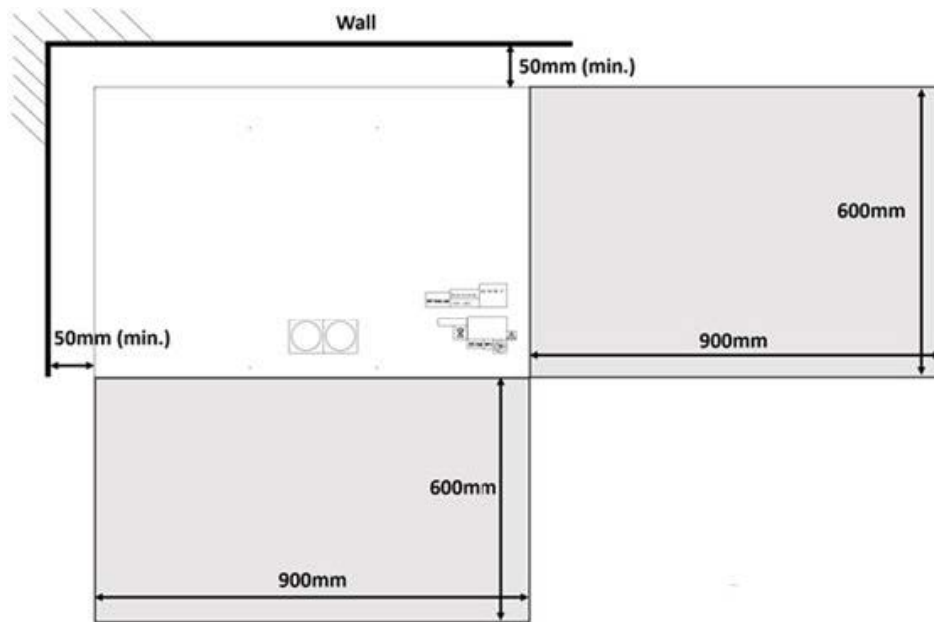
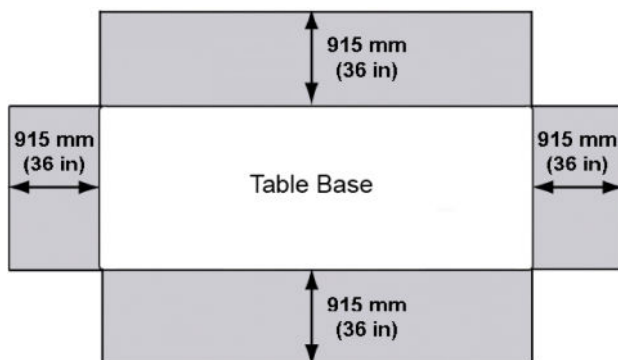

Figure 2-55 Table



Recommended Required Service Access Clearance is 36 in.

Minimum Required Service Access Clearance is 24 in

Figure 2-56 Wall Stand

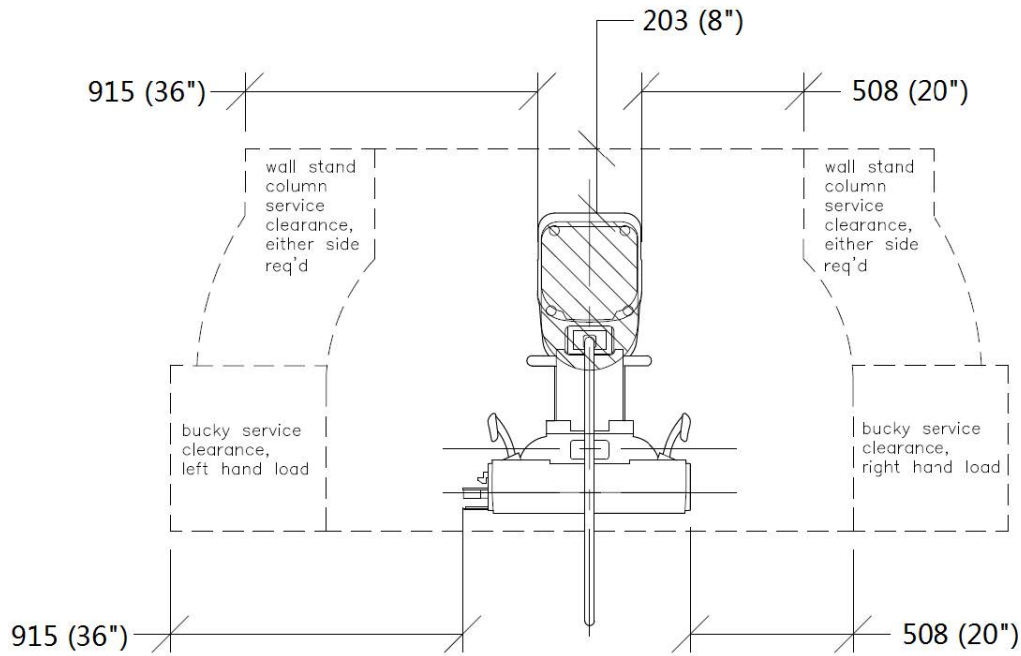

2.3.2 Clinical Access

NOTE

TOMO related requirement is not for G3A.

Make sure that you plan the room with the following clinical access requirements:

- Provide easy access to the patient table. Stretchers and other mobile hospital equipment must reach the table quickly.
- Table cannot be installed at 90 degrees to the ceiling stationary rails.
- When installing an extended-arm Wall Stand, the Wall Stand should be positioned directly in the center of the 3-meter/4-meter bridge if full tube angling capabilities are to be achieved.
- The Wall Stand can be configured to allow grid insertion direction from either the left or the right. Workflow and room dimensions should be considered.

2.3.3 Configurations and option

In Table below, Room configurations supported for the System are selected.

Table 2-10 Optima XR646 HD System Configuration

System	Wall Stand Type	Bridge Length, Wall Stand Position							
		2M Bridge				3M Bridge			
		Front	Back	Head	Foot	Front	Back	Head	Foot
WS Only	STD or EXT or Manual			√	√			√	√

Table 2-10 Optima XR646 HD System Configuration (Table continued)

System	Wall Stand Type	Bridge Length, Wall Stand Position							
		2M Bridge				3M Bridge			
		Front	Back	Head	Foot	Front	Back	Head	Foot
WS and Global G3 Table	STD or EXT or Manual							√	√
WS and Global G3 Std Table	STD or EXT or Manual							√	√
OTS Only (12M Rail)	NA								
Table Only	NA	√	√	√	√	√	√	√	√

Drawings for these room configurations are shown in the following pages. They include dimensional requirements between components and show Image Pasting applications (purchasable options) can be used in a room that meets those dimensional requirements.

Figure 2-57 Standard/Extended Arm Wall Stand only, at Foot with 2M/3M Bridge

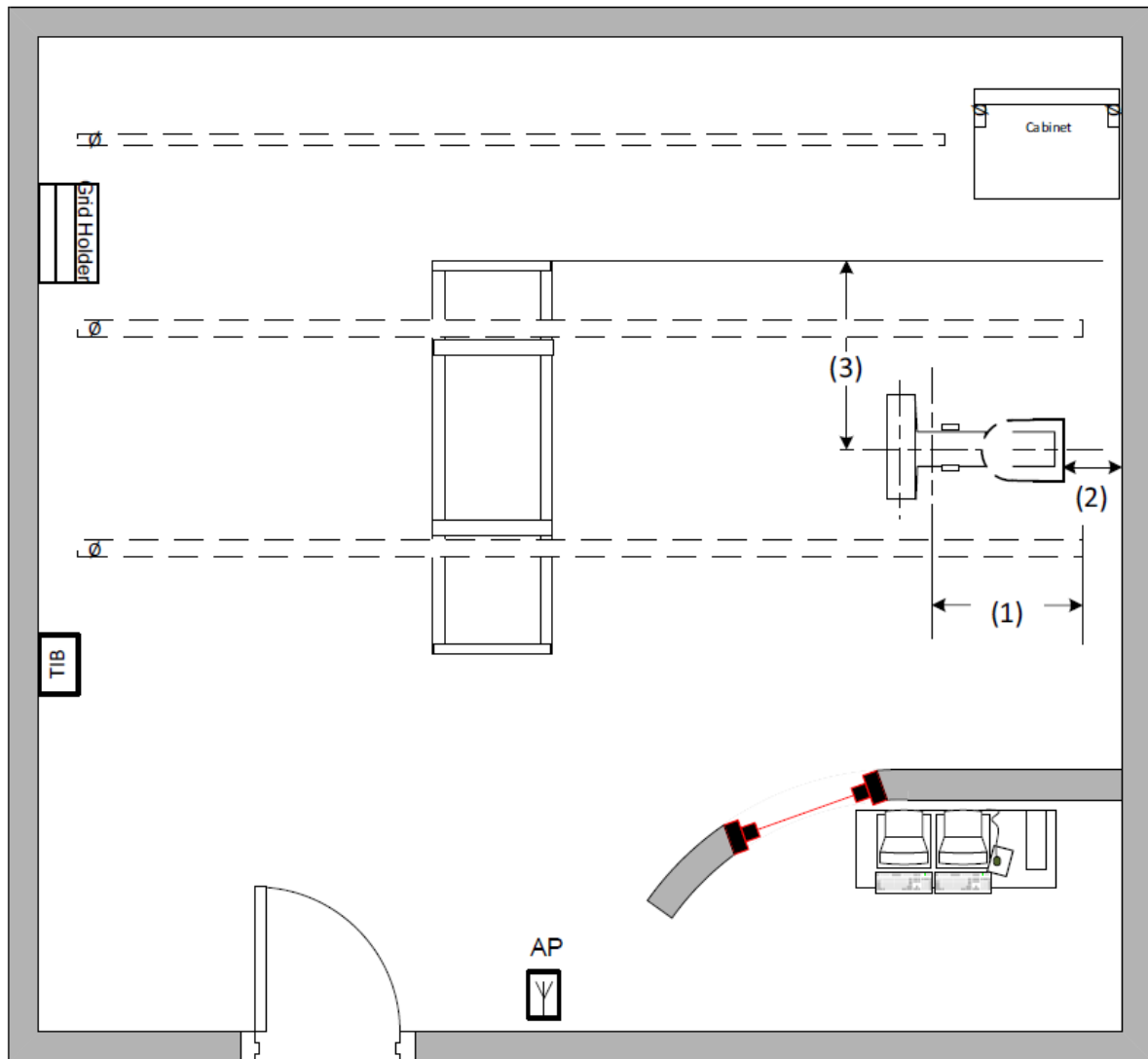

Table 2-11 Standard/Extended Arm Wall Stand only, at Foot with 2M/3M Bridge

ITEM	Bridge Length	Wall Stand	Dimension		Description	
				MM	In	
(1)		Standard WS	Min	630	24.8	Foot End of rail to center line of tilted Detector
		Ext WS	Min	1090	42.9	
(2)	ALL	ALL	Min	102	4.0	minimum service clearances.
(3)	2M	Standard	Min	960	37.8	Back of bridge to center line of Wallstand
			Max	1670	65.7	
		Ext WS	Min	960	37.8	
			Max	1210	47.6	
	3M	Standard	Min	960	37.8	
			Max	2735	107.7	
		Ext WS	Min	960	37.8	
			Max	2275	89.6	

Figure 2-58 Standard/Extended Arm Wall Stand only at Head with 2M/3M Bridge

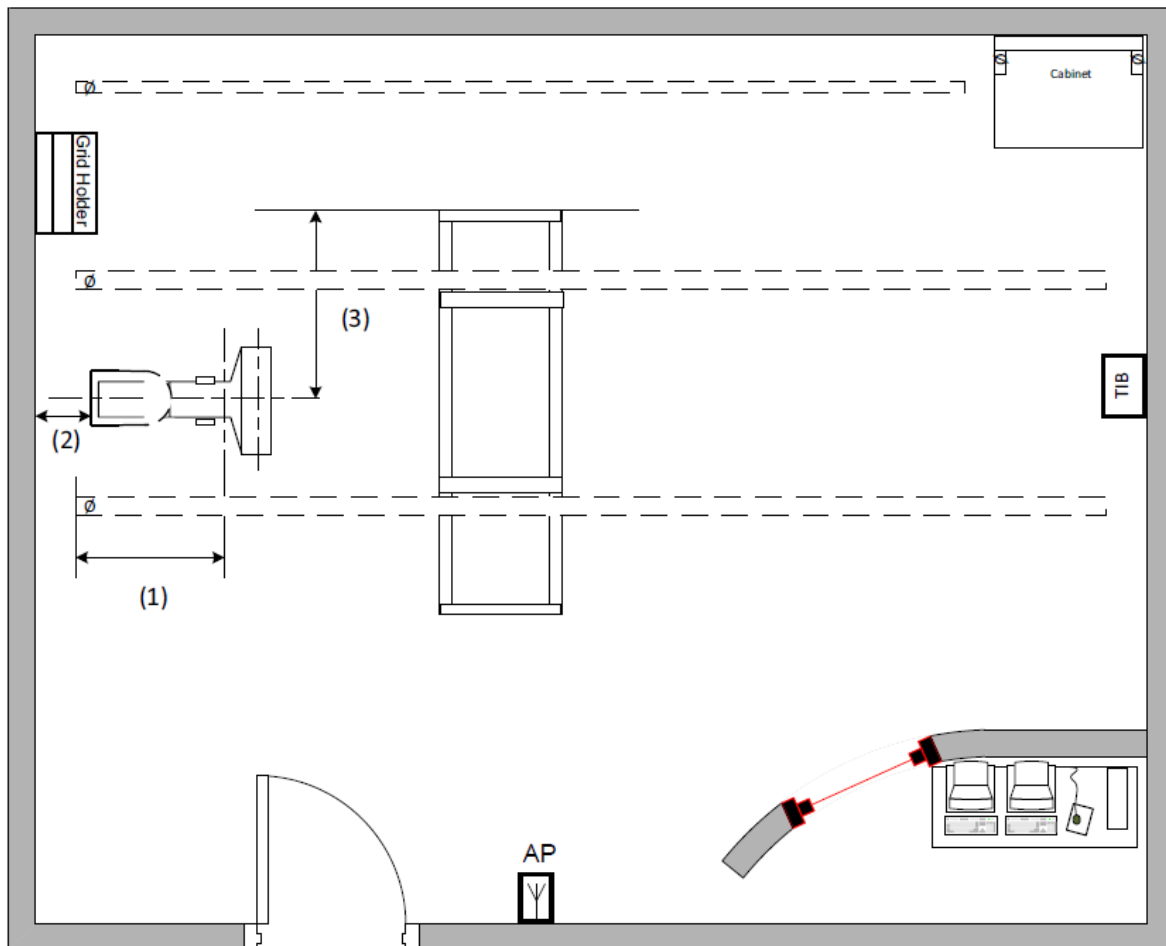

Table 2-12 Standard/Extended Arm Wall Stand only at Head with 2M/3M Bridge

ITEM	Bridge Length	Wall Stand	Dimension		Description	
				MM	In	
(1)	ALL	Standard WS	Min	630	24.8	Foot End of rail to center line of tilted Detector
		Ext WS	Min	1090	42.9	
(2)	ALL	ALL	Min	102	4.0	minimum service clearances.
(3)	2M	Standard	Min	960	37.8	Back of bridge to center line of Wallstand
			Max	1670	65.7	
		Ext WS	Min	960	37.8	
			Max	1210	47.6	
	3M	Standard	Min	960	37.8	
			Max	2735	107.7	
		Ext WS	Min	960	37.8	
			Max	2275	89.6	

Figure 2-59 Manual WS only on head/ foot side with 2m or 3m bridge

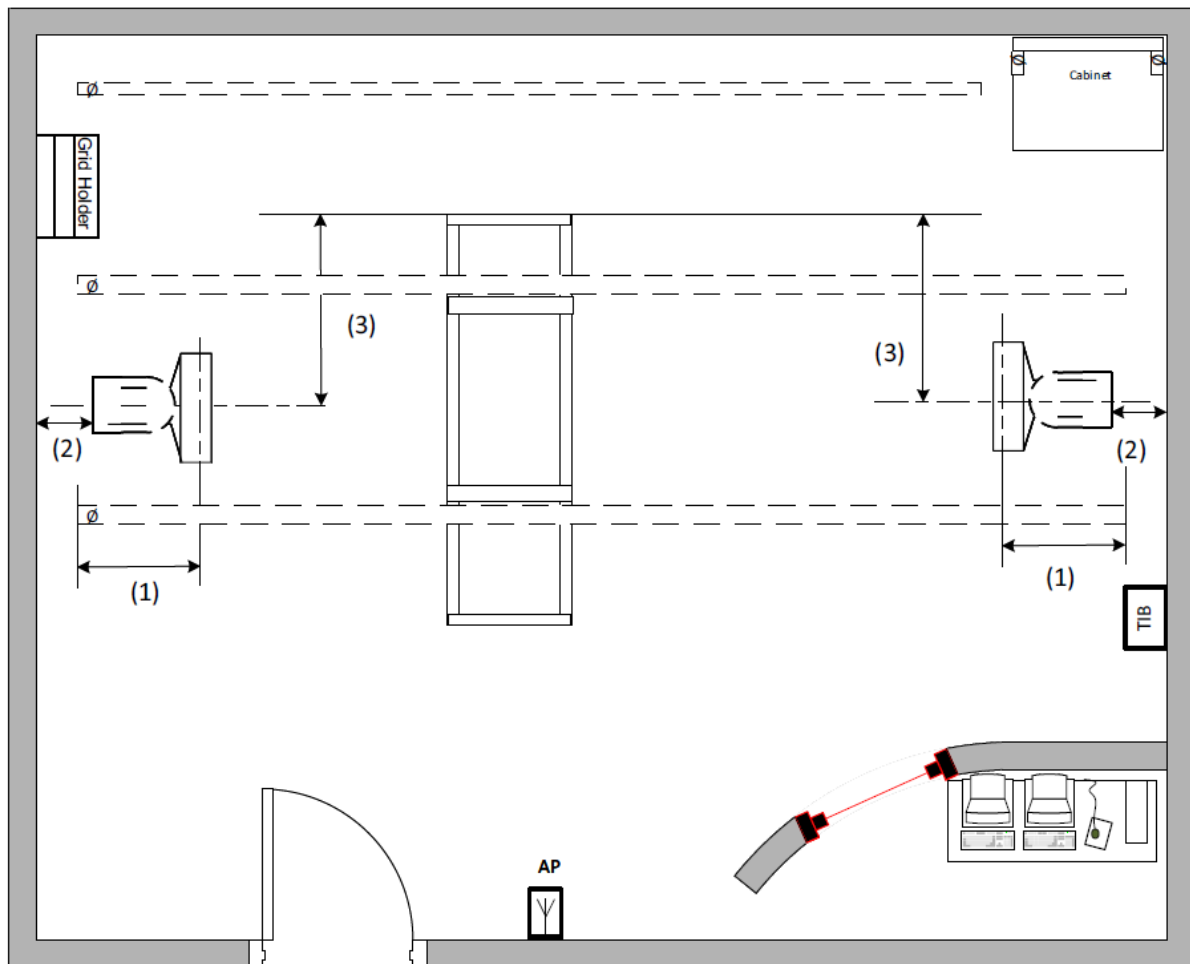

Table 2-13 Manual WS only on head/ foot side with 2m or 3m bridge

ITEM	Bridge Length	Wall Stand	Dimension		Description	
			MM	In		
(1)	ALL	Manual WS	Min	200	7.9	Foot End of rail to manual WS flim plane(manual WS didn't have titling mode, cal space 200mm)
(2)	ALL	Manual WS	Min	102	4.0	minimum service clearances.
(3)	2M	Manual WS	Min	960	37.8	Back of bridge to center line of Wallstand
			Max	1670	65.7	
	3M	Manual WS	Min	960	37.8	
			Max	2735	107.7	

Figure 2-60 Table and Standard/Extended Wall Stand at Foot with 3M Bridge

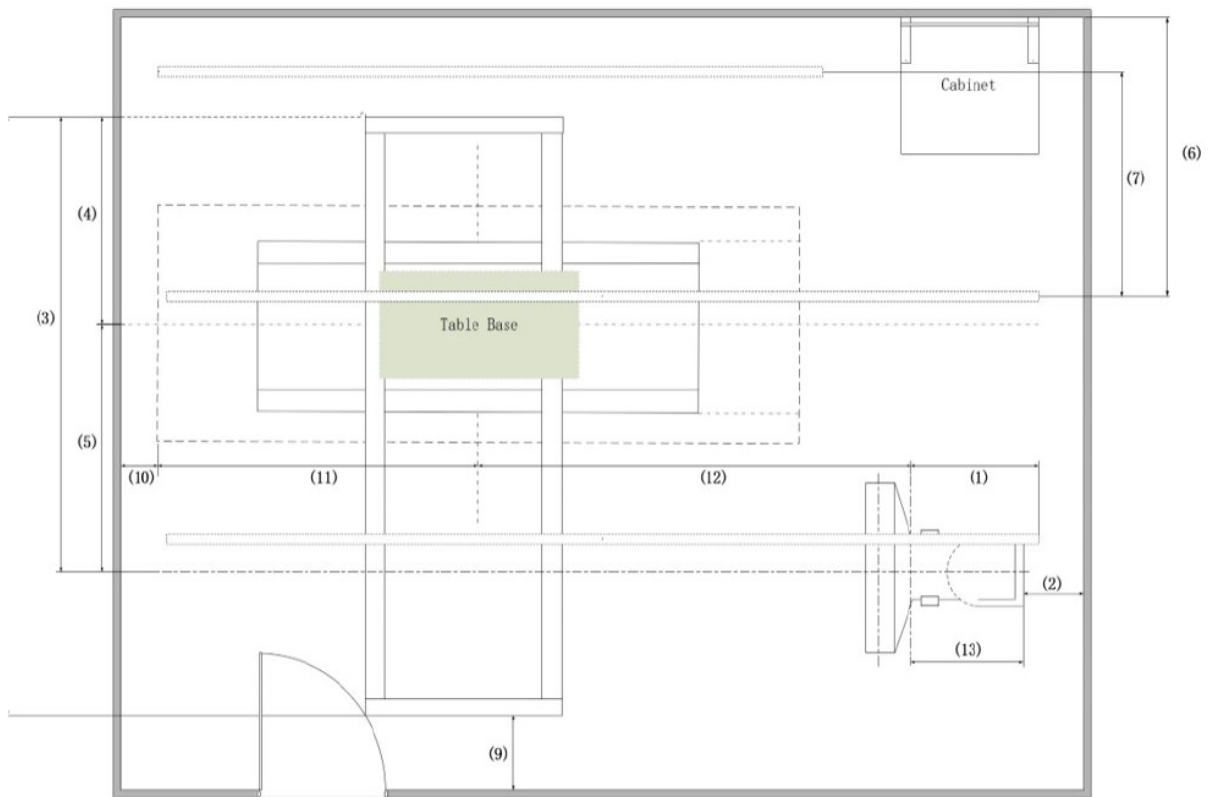

Table 2-14 Table and Standard/Extended Wall Stand at Foot with 3M Bridge

Item	WS	Limit Dimension	Dimension		Description
			mm	inch	
(1)	Std WS	Min	630	24.8	Foot end of rail to center line of tilted WS detector. 630 mm (530+100 Cal space)
	Ext WS	Min	1090	42.9	Foot end of rail to center line of tilted WS detector. 1060 mm (530 limit postion+460 collumn CL to focal spot +100 Cal space)
(2)	All	Min	102	4.0	Service clearance for WS installation. The Min value should be larger than 203 mm, the WS back cover could be installed or can be removed.

Table 2-14 Table and Standard/Extended Wall Stand at Foot with 3M Bridge (Table continued)

Item	WS	Limit Dimension			Description
(3)	All	Min	2060	77.2	Back of bridge to center line of WS. Min value 2060 (860 +100 Cal space + 700 distance between focal spot to back of OTS column +400 half table Width) Max value 2735 (bridge biggest travel range2835 - 100 Cal space)
		Max	2735	107.7	
(4)	All	Min	960	37.8	Back of bridge to center line of table. 960mm (860 +100 Cal space)
(5)	All	Min	1100	39.4	Table center line to WS center line. Min value 1100 mm (700 distance between focal spot to back of OTS column + 400 half table width)
(6)	Cable Drape 3M Bridge	Min	1000	39.4	Room wall to rear stationary rail center line
	Cable Chain 3M Bridge	Min	1000	39.4	Rear stationary rail center to Wall without space for cable routing behind bracket
		Min	1080	42.5	Rear stationary rail center to Wall with space for cable routing behind bracket
(7)	Cable Drape 3M Bridge	Min	883	34.8	Rear stationary rail center to cable drape rail center
	Cable Chain 3M Bridge	Fix	915	36	Rear stationary rail center to cable chain bracket center line.
(8)	All	Fix	3080	121.1	3M Bridge length
(9)	All	Min	100	3.9	Service clearance (front of bridge to wall)
(10)	Std WS	Min	60	2.4	Service clearance for Tabletop at head limit position.The min value for tabletop not touch the wall.
(11)	All	Fix	1540	60.6	Half length of G2 table tabletop longitudinal travel range
(12)	All	Min	X	XX	Center line of tilted Detector to center line of table in longitudinal, it decides room length per stretcher table used or not. If stretcher table is needed between table and WS, X=200mm WS tilted detector to surface +Wmm Stretcher table width + 900mm half length to table center + 100mm margin, Stretcher table width W could be adjusted per real table width. If no stretcher table, For Std WS, it need min 1440mm to allow cabinet installed at foot side or min 800mm with bigger (10) when cabinet installed at head side; For Ext WS, it need min 1150mm to allow cabinet installed at foot side or min 485mm with bigger (10) when cabinet installed at head side.
(13)	Std WS	Fix	734	28.9	Back cover of WS to center line of tilted WS detector.
	Ext WS	Fix	1156	45.5	Back cover of WS to center line of tilted WS detector.

Figure 2-61 Table and Manual Wall Stand at Foot with 3M Bridge

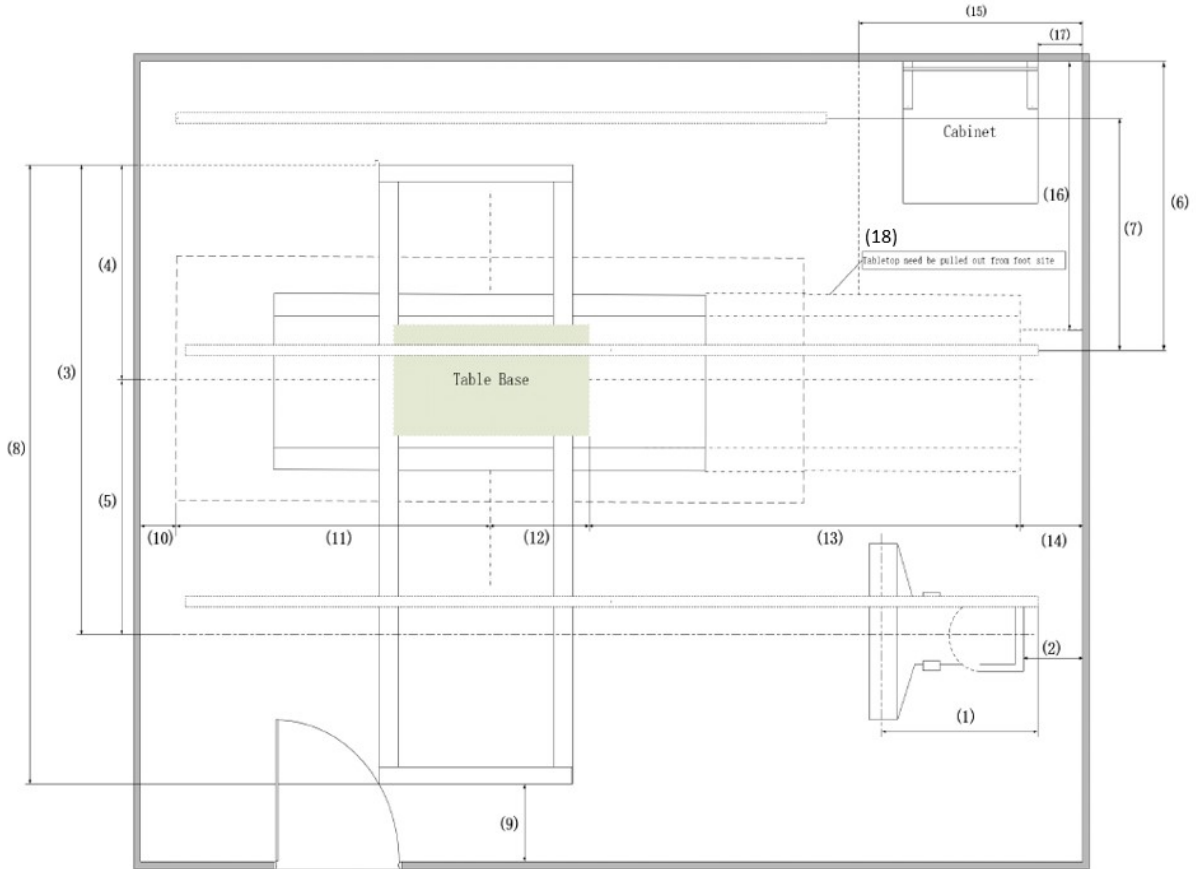

Table 2-15 Table and Manual Wall Stand at Foot with 3M Bridge

Item	Limit Dimension	Limit Dimension		Recommend Dimension		Description
		mm	inch	mm	inch	
(1)	Min	200	7.9	700	27.6	Foot End of rail to manual WS film plane(manual WS didn't have titling mode, cal space 200mm)
(2)	Min	102	4.0	400	15.7	Service clearance for WS installation. The Min value should be larger than 203 mm, the WS back cover could be installed or can be removed.
(3)	Min	2060	78	2300	90.6	Back of bridge to center line of WS. 1. With manual WS, the Min value should be larger than 2060 (860 +100 Cal space + 700 distance between focal spot to back of OTS column +400 half table Width) 2. with manual WS, the Max value should be less than 2735 (OTS biggest travel range2835 - 100 Cal space)
	Max	2735	107.7			
(4)	Min	960	37.8	1000	39.4	Back of bridge to center line of table. With manual WS, the Min value should be larger than 960 (860 +100 Cal space)
(5)	Min	1100	40.2	1300	51.2	Table center line to WS center line. The Min value should be larger than 1100 mm (700 distance between focal spot to back of OTS column + 400 half table width)

Table 2-15 Table and Manual Wall Stand at Foot with 3M Bridge (Table continued)

Item	Limit Dimension			Recommend Dimension		Description
(6)	Min	1000	39.4	1080	42.5	Room wall to rear stationary rail center line for cable drape version
	Min	1000	39.4	1080	42.5	Rear stationary rail center to Wall without space for cable routing behind bracket
	Min	1080	42.5	1120	44.1	Rear stationary rail center to Wall with space for cable routing behind bracket
(7)	Min	883	34.8	915	36	Rear stationary rail center to cable drape rail center for cable drape version
	Fix	915	36	915	36	Rear stationary rail center to cable chain bracket center line for cable chain version.
(8)	Fix	3077	121.1	3077	121.1	3M Bridge length
(9)	Min	100	3.9	500	19.7	Service clearance for OTS installation.
(10)	Min	50	2.0	100	3.9	Service clearance for Tabletop at head limit position. The min value for tabletop not touch the wall.
(11)	Fix	1660	65.4	1660	65.4	Half length of tabletop longitudinal travel range
(12)	Fix	660	26.0	660	26.0	Half length of table base(no tabletop)
(13)	Fix	2330	91.7	2330	91.7	Length of tabletop
(14)	Min	50	2.0	500	19.7	Service clearance for Tabletop pulled out. The min value for tabletop not touch the wall when it is pulled out. FE could stand byside of the tabletop if room length is short.
(15)	Min	1353	53.3	1400	55.1	Service clearance for cabinet.
(16)	Min	1307	51.5	1400	55.1	Service clearance for cabinet.
(17)	Min	200	7.9	200	7.9	Service clearance for cabinet.
(18)						Tabletop need be pulled out from foot site

Figure 2-62 Table and Standard/Extended Wall Stand at Head with 3M Bridge

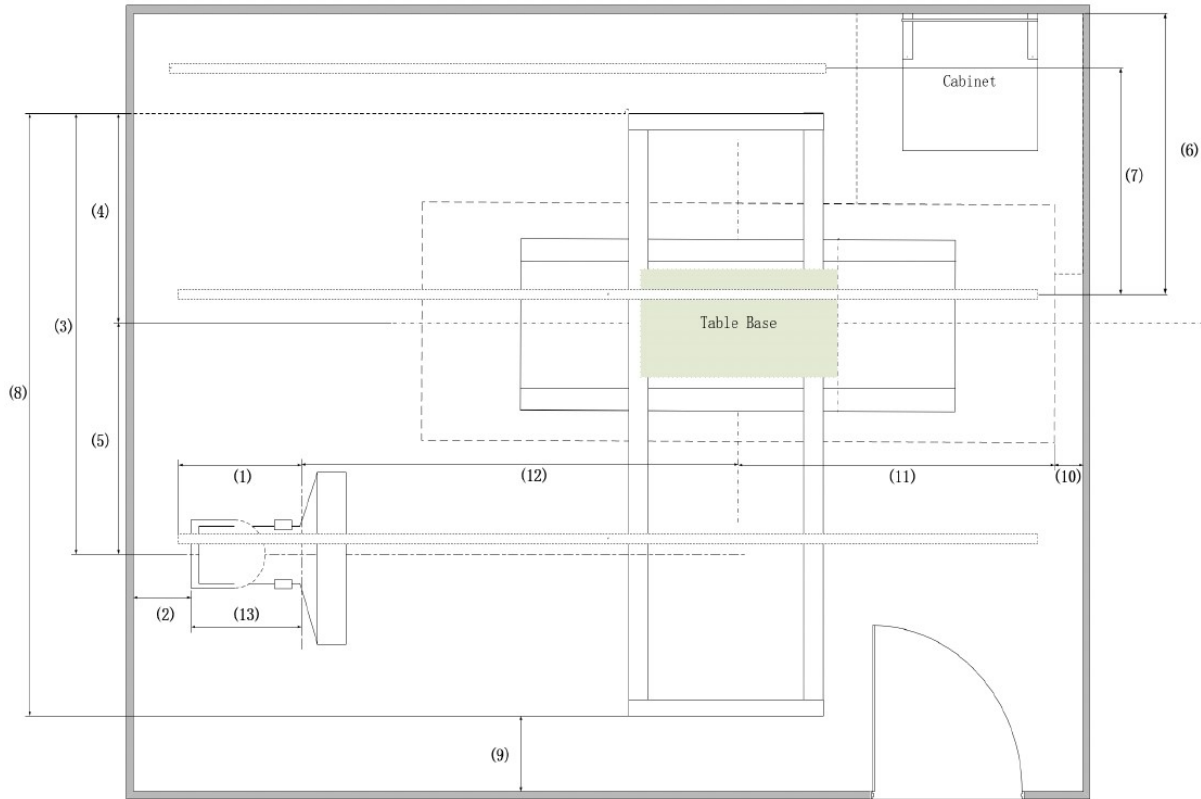

Table 2-16 Table and Standard/Extended Wall Stand at Head with 3M Bridge

Item	Config	Limit Dimension		Description	
		mm	inch		
(1)	Std WS	Min	630	24.8	Head end of rail to center line of tilted WS detector. 630 mm (530+100 Cal space)
	Ext WS	Min	1090	42.9	Head end of rail to center line of tilted WS detector. 1060 mm (530 limit position+460 column CL to focal spot +100 Cal space)
(2)	All	Min	102	4.0	Service clearance for WS installation. The Min value should be larger than 203 mm, the WS back cover could be installed or can be removed.
(3)	All	Min	2060	77.2	Back of bridge to center line of WS.
		Max	2735	107.9	Min value 2060 (860 +100 Cal space + 700 distance between focal spot to back of OTS column +400 half table Width) Max value 2735 (bridge biggest travel range2835 - 100 Cal space)
(4)	All	Min	960	37.8	Back of bridge to center line of table. 960mm (860 +100 Cal space)
(5)	All	Min	1100	39.4	Table center line to WS center line. Min value 1100 mm (700 distance between focal spot to back of OTS column + 400 half table width)
(6)	Cable Drape 3M Bridge	Min	1000	39.4	Room wall to rear stationary rail center line
	Cable Chain 3M Bridge	Min	1000	39.4	Rear stationary rail center to Wall without space for cable routing behind bracket

Table 2-16 Table and Standard/Extended Wall Stand at Head with 3M Bridge (Table continued)

Item	Config	Limit Dimension			Description
		Min			
		Min	1080	42.5	Rear stationary rail center to Wall with space for cable routing behind bracket
(7)	Cable Drape 3M Bridge	Min	883	34.8	Rear stationary rail center to cable drape rail center
	Cable Chain 3M Bridge	Fix	915	36	Rear stationary rail center to cable chain bracket center line.
(8)	All	Fix	3088	121.1	3M Bridge length
(9)	All	Min	100	3.9	Service clearance (front of bridge to wall)
(10)	Std WS	Min	60	2.4	Service clearance for Tabletop at foot limit position. The min value for tabletop not touch the wall.
(11)	All	Fix	1540	60.6	Half length of G2 table tabletop longitudinal travel range
(12)	All	Min	X	XX	Center line of tilted Detector to center line of table in longitudinal, it decides room length per stretcher table used or not. If stretcher table is needed between table and WS, X=200mm WS tilted detector to surface +Wmm Stretcher table width + 900mm half length to table center + 100mm margin, Stretcher table width W could be adjusted per real table width. If no stretcher table, For Std WS, it need min 1440mm to allow cabinet installed at head side or min 800mm with bigger (10) when cabinet installed at foot side; For Ext WS, it need min 1150mm to allow cabinet installed at head side or min 485mm with bigger (10) when cabinet installed at foot side.
(13)	Std WS	Fix	734	28.9	Back cover of WS to center line of tilted WS detector.
	Ext WS	Fix	1156	45.5	Back cover of WS to center line of tilted WS detector.

Figure 2-63 Table and Manual Wall Stand at Head with 3M Bridge

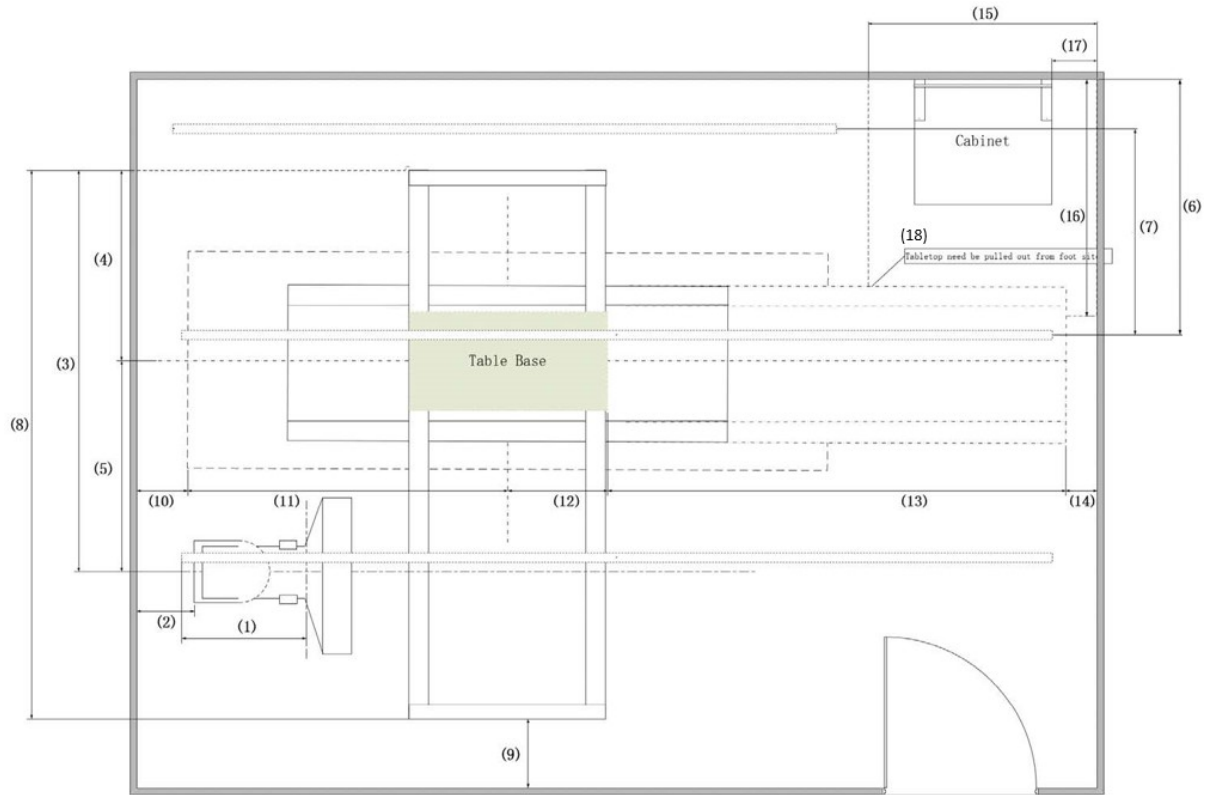

Table 2-17 Table and Manual Wall Stand at Head with 3M Bridge

Item	Limit	Dimension		Recommend Dimension		Description
		mm	inch	mm	inch	
(1)	Min	200	7.9	700	27.6	Foot End of rail to manual WS film plane(manual WS didn't have titling mode, cal space 200mm)
(2)	Min	102	4.0	400	15.7	Service clearance for WS installation. The Min value should be larger than 203 mm, the WS back cover could be installed or can be removed.
(3)	Min	2060	78	2300	90.6	Back of bridge to center line of WS. 1. With manual WS, the Min value should be larger than 2060 (860 +100 Cal space + 700 distance between focal spot to back of OTS column +400 half table Width) 2. with manual WS, the Max value should be less than 2735 (OTS biggest travel range2835 - 100 Cal space)
	Max	2735	107.7			
(4)	Min	960	37.8	1000	39.4	Back of bridge to center line of table. With manual WS, the Min value should be larger than 960 (860 +100 Cal space)
(5)	Min	1100	40.2	1300	51.2	Table center line to WS center line. The Min value should be larger than 1100 mm (700 distance between focal spot to back of OTS column + 400 half table width)
(6)	Min	1000	39.4	1080	42.5	Room wall to rear stationary rail center line

Table 2-17 Table and Manual Wall Stand at Head with 3M Bridge (Table continued)

Item	Limit Dimension			Recommend Dimension		Description
	Min	1000	39.4	1080	42.5	Rear stationary rail center to Wall without space for cable routing behind bracket
	Min	1080	42.5	1120	44.1	Rear stationary rail center to Wall with space for cable routing behind bracket
(7)	Min	883	34.8	915	36	Rear stationary rail center to cable drape rail center
	Fix	915	36	915	36	Rear stationary rail center to cable chain bracket center line
(8)	Fix	3077	121.1	3077	121.1	3M Bridge length
(9)	Min	100	3.9	500	19.7	Service clearance for OTS installation.
(10)	Min	50	2.0	100	3.9	Service clearance for Tabletop at head limit position. The min value for tabletop not touch the wall.
(11)	Fix	1660	65.4	1660	65.4	Half length of tabletop longitudinal travel range
(12)	Fix	660	26.0	660	26.0	Half length of table frame(no tabletop)
(13)	Fix	2330	91.7	2330	91.7	Length of tabletop
(14)	Min	50	2.0	500	19.7	Service clearance for Tabletop pulled out. The min value for tabletop not touch the wall when it is pulled out. FE could stand byside of the tabletop if room length is short.
(15)	Min	1353	53.3	1400	55.1	Service clearance for cabinet.
(16)	Min	1307	51.5	1400	55.1	Service clearance for cabinet.
(17)	Min	200	7.9	200	7.9	Service clearance for cabinet.
(18)						Tabletop need be pulled out from foot site

2.3.3.1 Room Layout Analysis for Table & WS

1. Cabinet installed in foot side could meet smaller room size than in head (or foot) side.
2. Item(5) length X decides room length and system advanced application. If WS cross Table TOMO or Ext WS TOMO is required, then stretcher table is needed between WS and table, $X=200\text{mm}$ WS tilted detector to surface + W mm Stretcher table width + 900mm half length to table center+100mm margin, Stretcher table width W could be adjusted per real table width.

2.3.3.2 Summary Result

Table 2-18 Summary Result

Without Control Room	Item	WS	Without stretcher table	With stretcher table
Min Length	(2)+(10)+(11)+(12)+(13)	Std WD	3977	3737+ W
		Ext WD	4209	4159+ W
Min Width	(6)+(7)+(8)+(9)+43	All	260+(8)	1450+L or 260+(8)

Table 2-19 Stretcher Table Model

Stretcher Table Model	H	L	W
Radiographic	750	2188	726

Table 2-19 Stretcher Table Model (Table continued)

Stretcher Table Model	H	L	W
S1700JM Carbon Fiber	700	2200	650
GST-2	700	2004	640

**NOTE**

1. Room Width $1450+L$ (Wall to table front edge $1350+100$ margin+ stretcher table length L) is required if stretcher table could go through front side door. But only width 3325mm is required if stretcher table could go through head/foot side door.
2. Above data are MIN size with precise positioning, recommended room size is $5500*5000$.
3. Ext WS room min length 4209mm is rarely used, normally need $4159+W$ because customer buy Ext WS to apply stretcher table for cross table TOMO and Ext WS TOMO.

2.3.3.3 Min size room template with Table & WS at Foot(3m bridge)

Assumption:

1. Below 3 drawings are min size rooms according to previous room layout analysis, only for reference and understanding help. Need design room layout per real site room size and system configuration.
2. No considering room door position and control room, only considering main system layout.

Make table and WS a little nearer to front side, so below 2 distances are bigger than min size: back of bridge to table center, table center to WS center.

3. Choose the rail type most fit for the min room, make the rail nearer to head side to guarantee OTS travel range to cover head side of table, so the distance between end of rail and tilted detector is not min size in the template.

Figure 2-64 MIN Size Room STD WS with Stretcher Table

STD WS with stretcher table

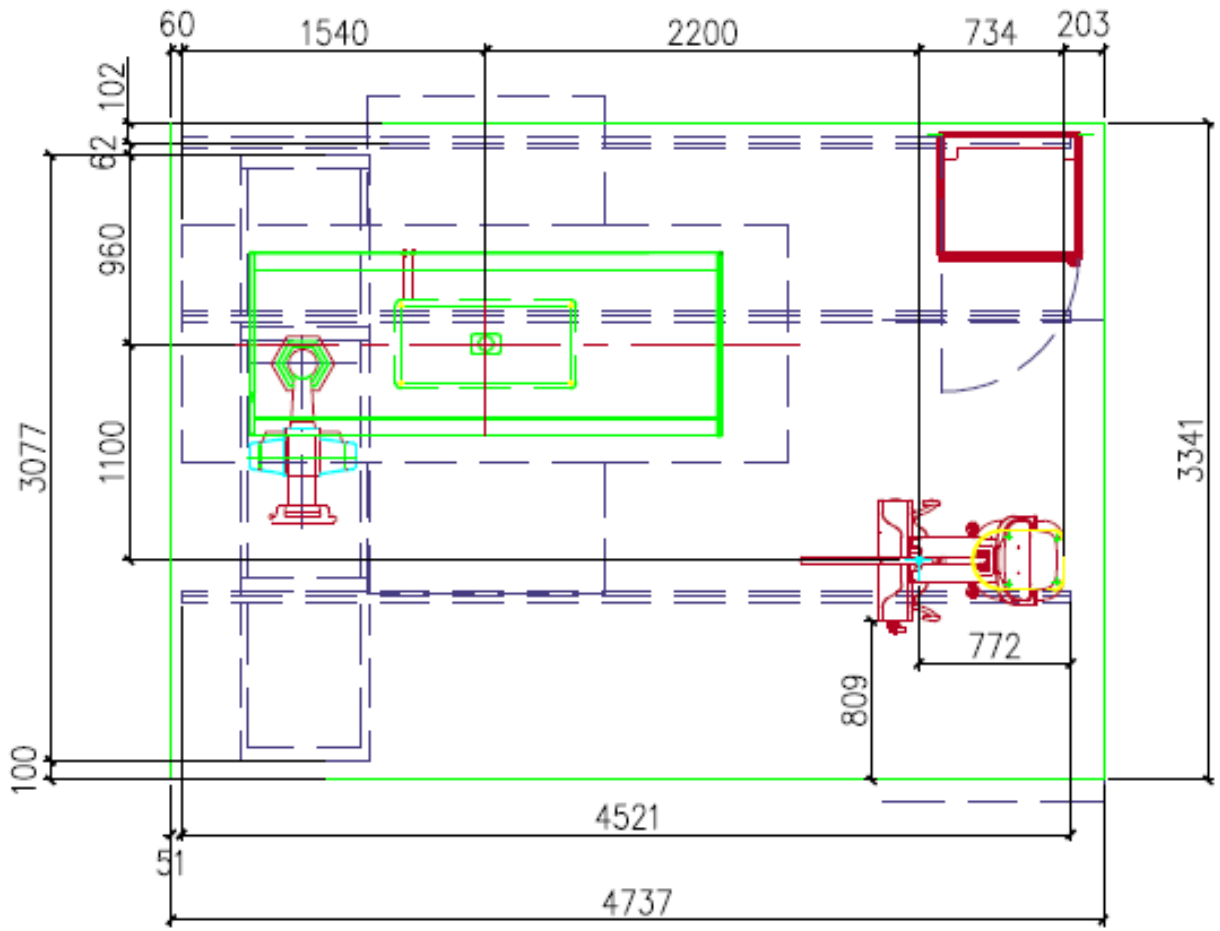

Figure 2-65 MIN Size Room STD WS without Stretcher Table

STD WS without stretcher table

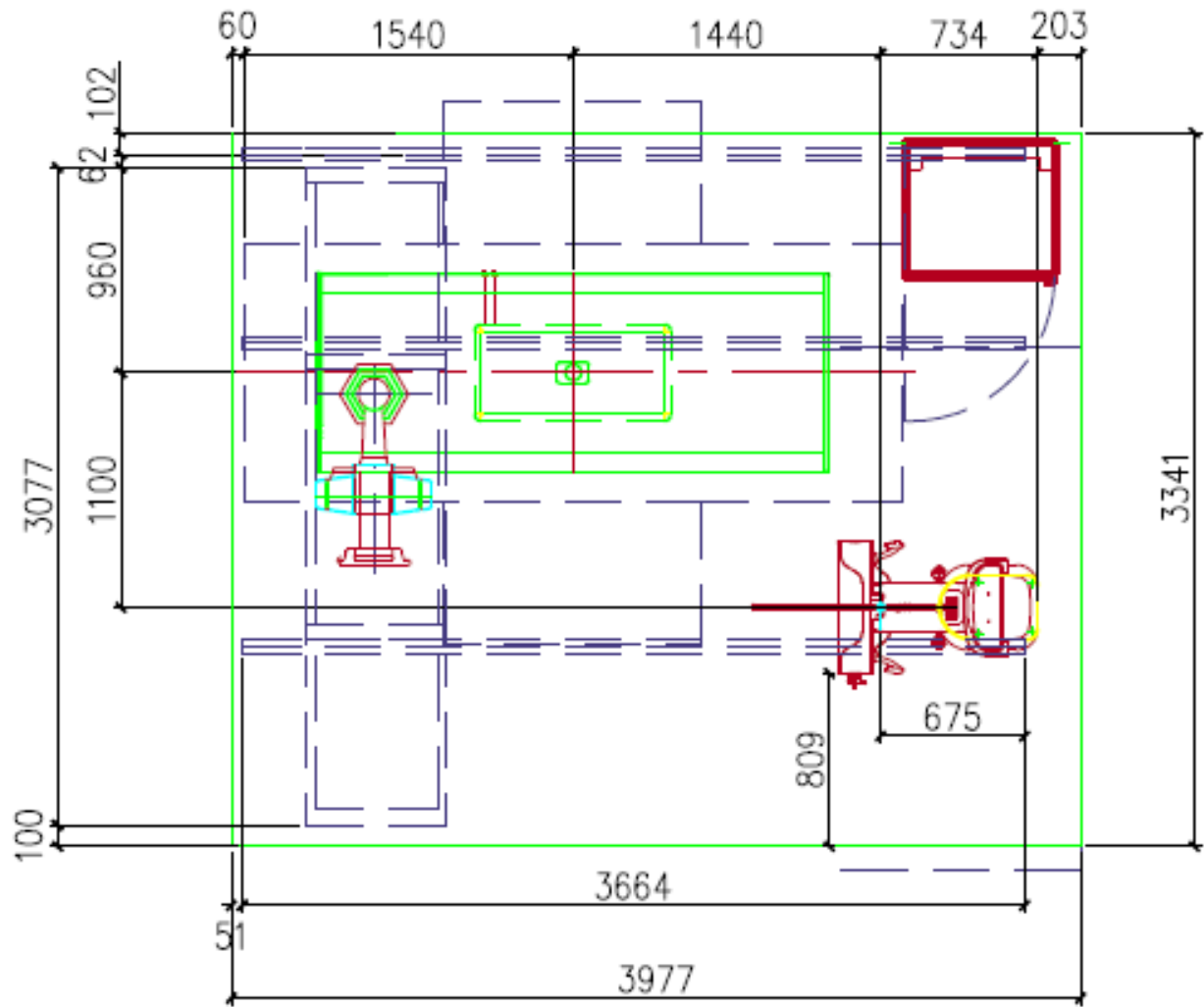

Figure 2-66 MIN Size Room EXT WS with Stretcher Table

EXT WS with stretcher table

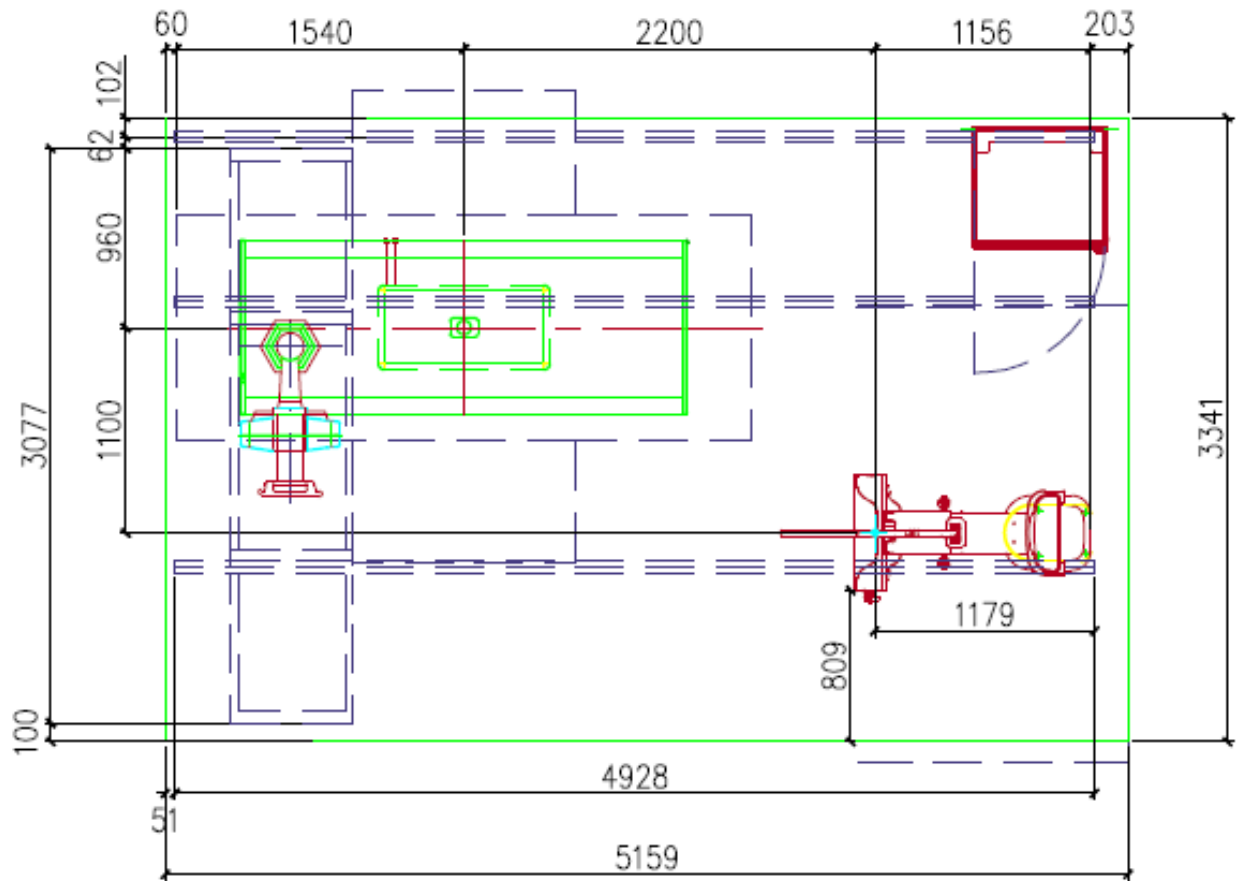
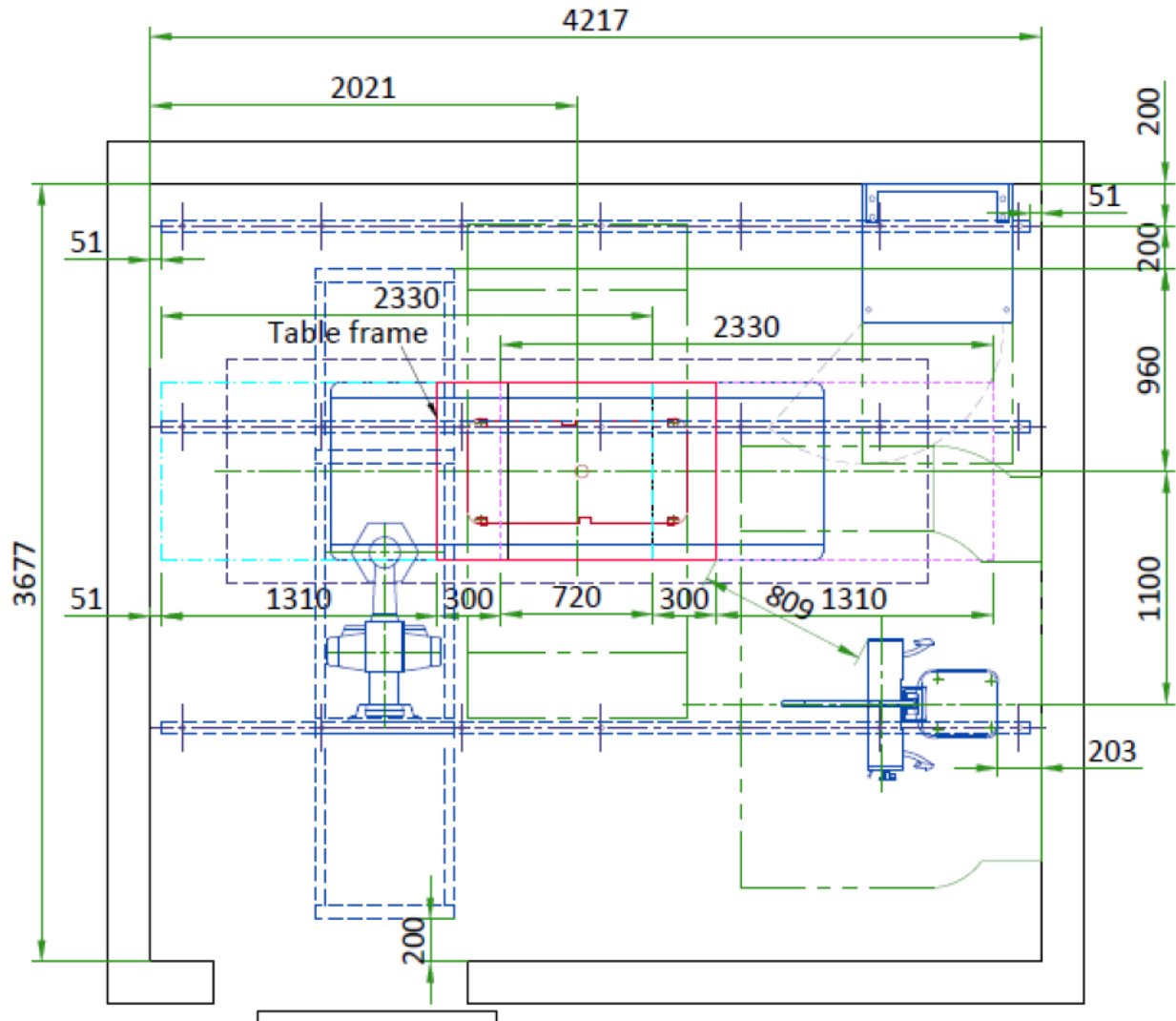

Figure 2-67 Min Room Layout for Limited Service Clearance (Global G3 Std table & WS) Without Control Room



NOTE

Min Room Layout for Limited Service Clearance (Standard table & WS) Without Control Room is Only for Special Case and Must Meet Below Limitations.

If Service FE and customer accept below 2 limitations:

1. Table top can't be pulled out in exam room, so table actuator and table top can't be replaced in exam room. (Need take table out of the room if have to pull overall tabletop out for troubleshooting)
2. FE need install tabletop out of exam room, then push table into exam room.

Then system could be installed into the site with below conditions:

1. Min room size: 4217*3677mm.
2. Tabletop could be pushed to head/foot side until 300mm table frame is exposed, then the bolt of top rear cover could be exposed. Remove all table cover. most components could be repaired except replacing table actuator and tabletop.

2.3.3.4 Room Size Summary

- If with control room, width need add min 1100mm, so min room size is 4217mm*4800mm.
- If 2200mm stretcher table is used, width need min 4000mm (200+200+960+table width/2+2200) to push it into exposure room, so min room size is 4217mm*4000mm.
- Applicable to below 2 configurations: Global G3 Std table & G3 Std WS.

Figure 2-68 Clinical Impact when Global G3Std Table & WS in Proteus Room with Min Ceiling Height 2500mm

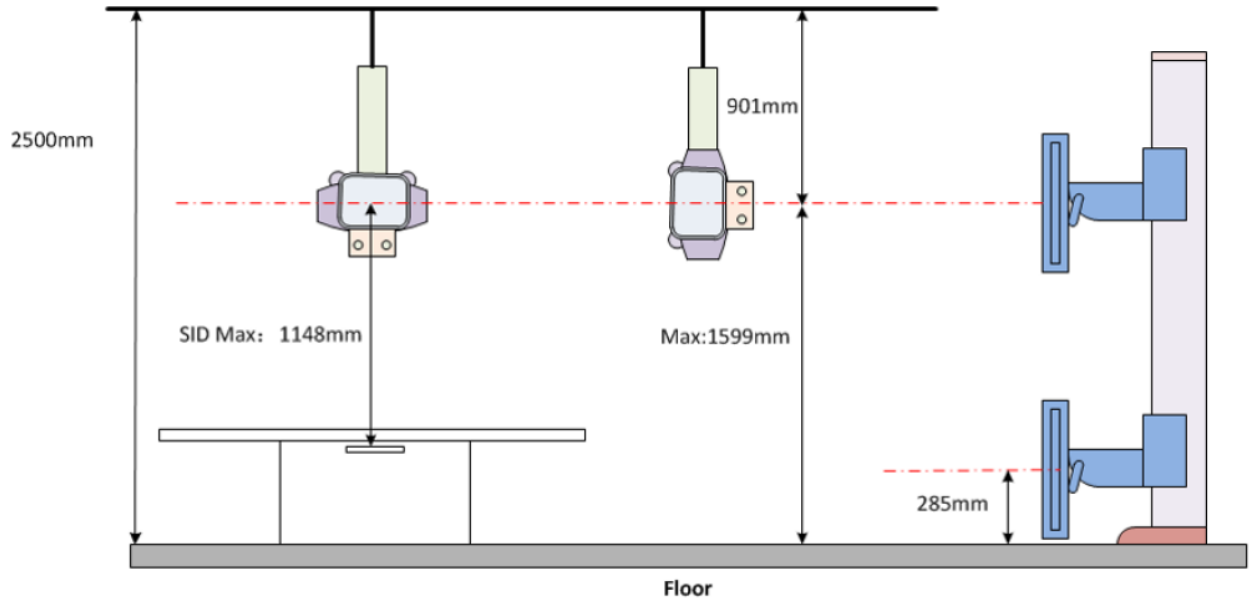

If Global Std.Table & WS are installed in 2.5m ceiling height room, the clinical impact is:

- For table mode, the tabletop max height is 67.3cm while maintaining 100cm SID. This impact the operator to bend for operation, it is manageable from the operator’s perspective. We have proven use of a similar height in the Brivo 385 DRF which is a fixed height table. It is fixed at 70.1 cm. We think the difference of 2.8cm or about 1 in. is small enough to equate the usability of this height.
- The max SID is 114.8cm when tabletop at lowest position, we are within a customer’s expectation concerning the maximum available SID.
- For WS coverage, tube max height is 159.9cm, for 185cm (95% coverage) height patient, it can provide coverage for great majority of chest exams, it’s usable. While many neck or head exams at the Wallstand may require the patient to be seated.

Table 2-20 Room size summary for full service function summary

Configuration	Global G3 Std Table + Standard WS (L*W*H)		Global G3 Std Table + Extended WS (L*W*H)		Manual WS Only (L*W*H)	
	Min (mm)	Recommend (mm)	Min (mm)	Recommend (mm)	Min (mm)	Recommend (mm)
Without control room Without stretcher table	4750*3341*2686	5250*4000*2986	4750*3341*2750	5250*4000*2986	3800*3000*2686	4000*3500*2986
Without control room With stretcher table	4750*4000*2686	5250*5000*2986	4750*4000*2750	5250*5000*2986	3800*3000*2686	4000*3500*2986

Table 2-20 Room size summary for full service function summary (Table continued)

Configuration	Global G3 Std Table + Standard WS (L*W*H)		Global G3 Std Table + Extended WS (L*W*H)		Manual WS Only (L*W*H)	
With control room	4750*4800*2686	5250*5000*2986	4750*4800*2750	5250*5000*2986	3800*3500*2686	4000*4000*2986

**NOTE**

Extended WS: MIN Ceiling Height=2750mm

Table 2-21 Min Room size for limited service function (special case)

Configuration	Standard Table + Manual WS or Standard WS(L*W*H)
Room type	Min (mm)
w/o control room w/o stretcher table	4217*3341*2686
w/o control room w stretcher table	4217*4000*2686
w control room	4217*4800*2686

Need Service FE and customer accept below 2 limitations:

- Tabletop can't be pulled out in exam room, so table actuator and tabletop can't be replaced in exam room. (Need take table out of the room if have to pull overall tabletop out for troubleshooting)
- FE need install tabletop out of exam room, then push table into exam room.

Then system could be installed into the site with below conditions and above limitations:

- Min room size: 4217*3677mm.
- Tabletop could be pushed to head/foot side until 300mm table frame is exposed, then the bolt of top rear cover could be exposed. Remove all table cover. Most components could be repaired except replacing table actuator and tabletop.

2.4 Seismic

2.4.1 Overview

Seismic requirements are determined and specified by the hospital/Design Professional of record and may require approval by the specific state or country agency.

Seismic attachment hardware shown on seismic calculations may differ from hardware supplied with system. Any additional hardware that is required will be the responsibility of the institution and/or their contractor. Contact your local GE HealthCare representative to obtain seismic calculations.

Seismic calculations are per California Building Code (CBC) and International Building Code (IBC).

2.4.2 Calculations

Seismic calculations can be obtained for the following:

- Global G3 Table (GCTBL-C3/GCTBL-C33)
- Global Standard Table (GCTBL-C5)

- Detector BIN 5765692
- Tether Interface Box 5765910/5876669
- HP Workstation
- AP Assembly
- Grid Box
- G3 Wall Stand GCWS-C3
- G3 Extended Wall Stand GCEWS-C3
- Manual Wall stand GCMWS-C5
- Cabinet GCC-C3
- OTS 2m Bridge 5693326
- OTS 3m Bridge 5693325

2.4.3 Center of gravity information

2.4.3.1 Global G3 table (GCTBL-C3/GCTBL-C33)

Figure 2-69 C. G. WT. =700Kg (including patient weight 320Kg)

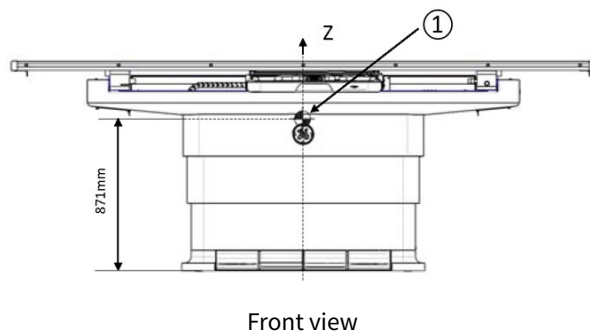

Table Top Floating range:

±340mm in X direction

±140mm in y direction

Table Top can Float to four limit position:

(+340mm, -140mm), (+340mm, +140mm)

with housing travelled to right limit;

(-340mm, -140mm), (-340mm, +140mm)

with Housing travelled to left limit



NOTE

Table in full extension height, table top are in center position(0,0) with housing in the center (normal case).

Item	Description
1	C.G.WT.= 700Kg (Including patient weight 320Kg)

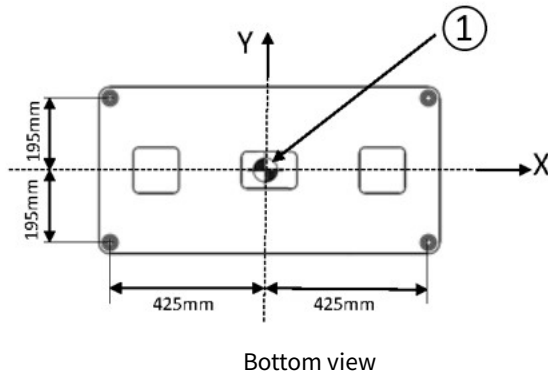

Item	Description
1	C.G.WT.= 700Kg (Including patient weight 320Kg)

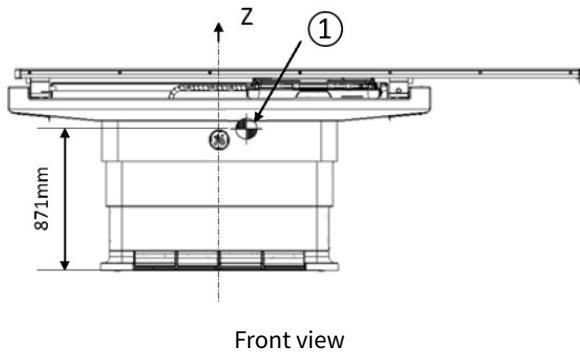

Table Top Floating range:

±340mm in X direction

±140mm in y direction

Table Top can Float to four limit position:

(+340mm, -140mm), (+340mm, +140mm)

with housing travelled to right limit;

(-340mm, -140mm), (-340mm, +140mm)

with Housing travelled to left limit



NOTE

Table in full extension height, table top floated to farthest corner(+340mm,+140mm) position, with housing travelled to right limit.

Item	Description
1	C.G.WT.=700kg Max (including 320kg Patient weight)

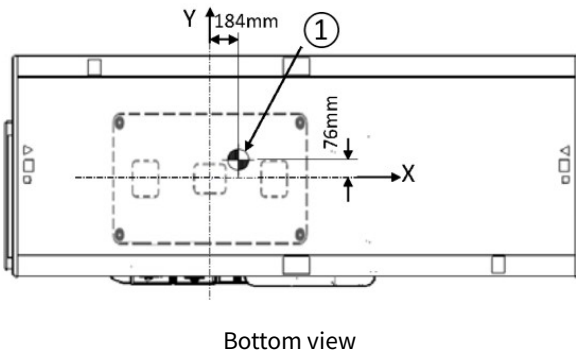

Item	Description
1	C.G.WT.=700kg Max (including 320kg Patient weight)

2.4.3.2 Global Standard Table (GCTBL-C5)

Figure 2-70 C. G. WT. = 570Kg (including patient weight 250Kg)

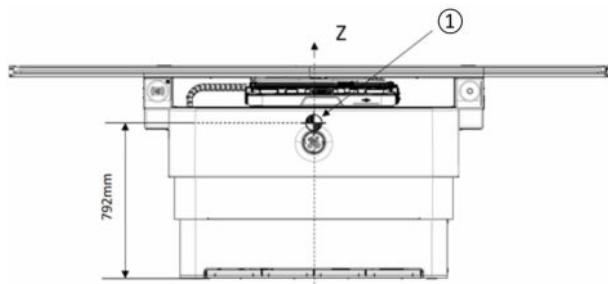

Front view

Table Top Floating range:

±495mm in X direction
 ±100mm in Y direction

Table Top can Float to four limit position:

(+495mm, -100mm), (+495mm, +100mm)
 with housing travelled to right limit;
 (-495mm, -100mm), (-495mm, +100mm)
 with Housing travelled to left limit



NOTE

Table in full extension height, table top are in center position(0,0) with housing in the center (normal case).

Item	Description
1	C.G.WT. = 570Kg (Including patient weight 250Kg)

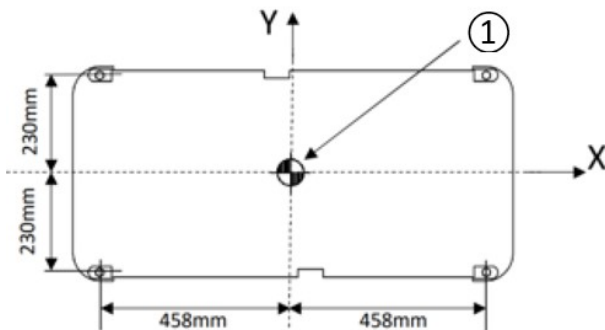

Bottom view

Item	Description
1	C.G.WT. = 570Kg (Including patient weight 250Kg)

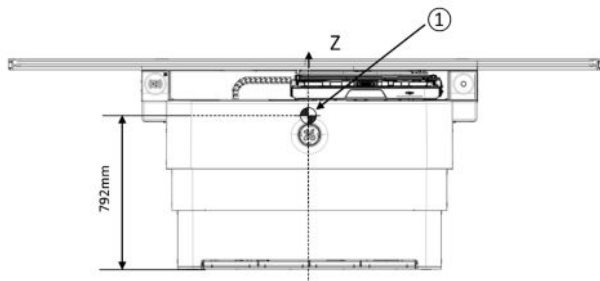

Front view

Table Top Floating range:

±495mm in X direction
 ±100mm in Y direction

Table Top can Float to four limit position:

(+495mm, -100mm), (+495mm, +100mm)
 with housing travelled to right limit;
 (-495mm, -100mm), (-495mm, +100mm)
 with Housing travelled to left limit



NOTE

Table in full extension height, table top floated to farthest corner (+495mm,100mm) position, with housing travelled to right limit (worst case).

Item	Description
1	C.G.WT. = 570Kg (Including patient weight 250Kg)

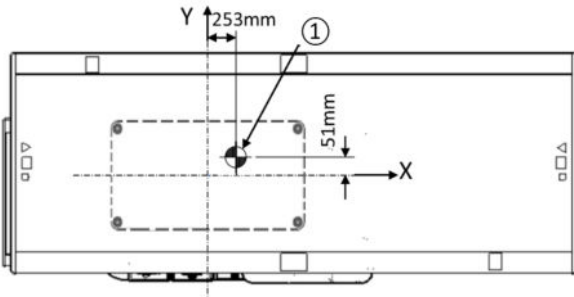

Bottom view

Item	Description
1	C.G.WT. = 570Kg Max (Including 250Kg patient weight)

2.4.3.3 Detector bin 5765692

Wall mounting (Default) or Floor mounting (Bracket GE HealthCare PN: 5816733)

Figure 2-71 C. G. WT. = 18Kg with both 17x17 and 10x12 detectors

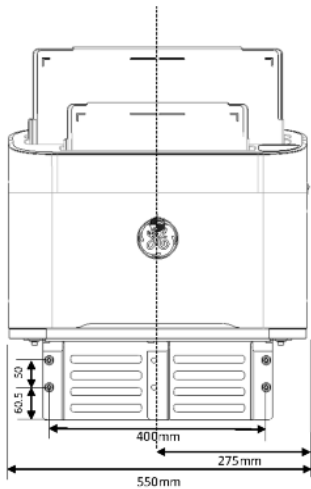

Front view

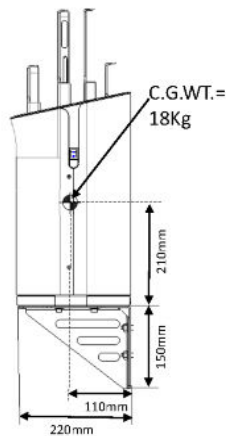

Side view

Wall mounting

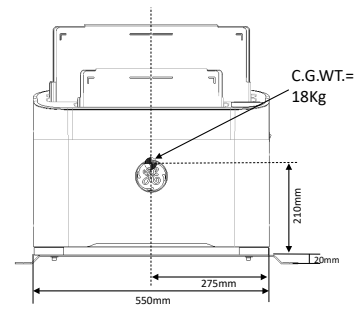

Front view

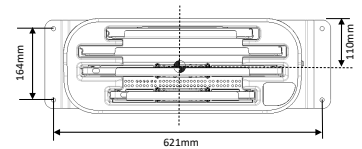

Top view

Floor mounting

2.4.3.4 Tether Interface Box 5765910/5876669

Figure 2-72 TIB C. G. WT. = 6Kg

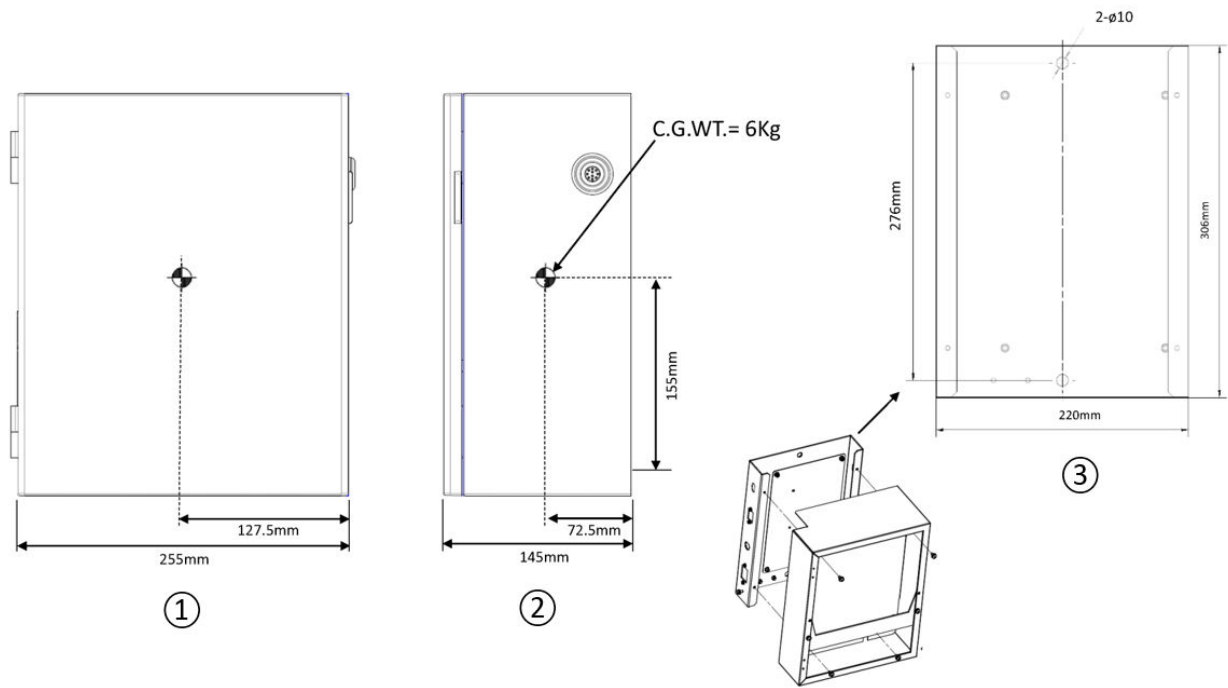

Item	Description
1	Front view
2	Side view
3	Plate Thickness 2mm

2.4.3.5 HP workstation

Computer Seismic mounting bracket GE HealthCare PN 5813338 (Steel, Thickness 3mm)

Figure 2-73 Floor Mounting Weight Z440 (8770000-24): 17.5Kg max.

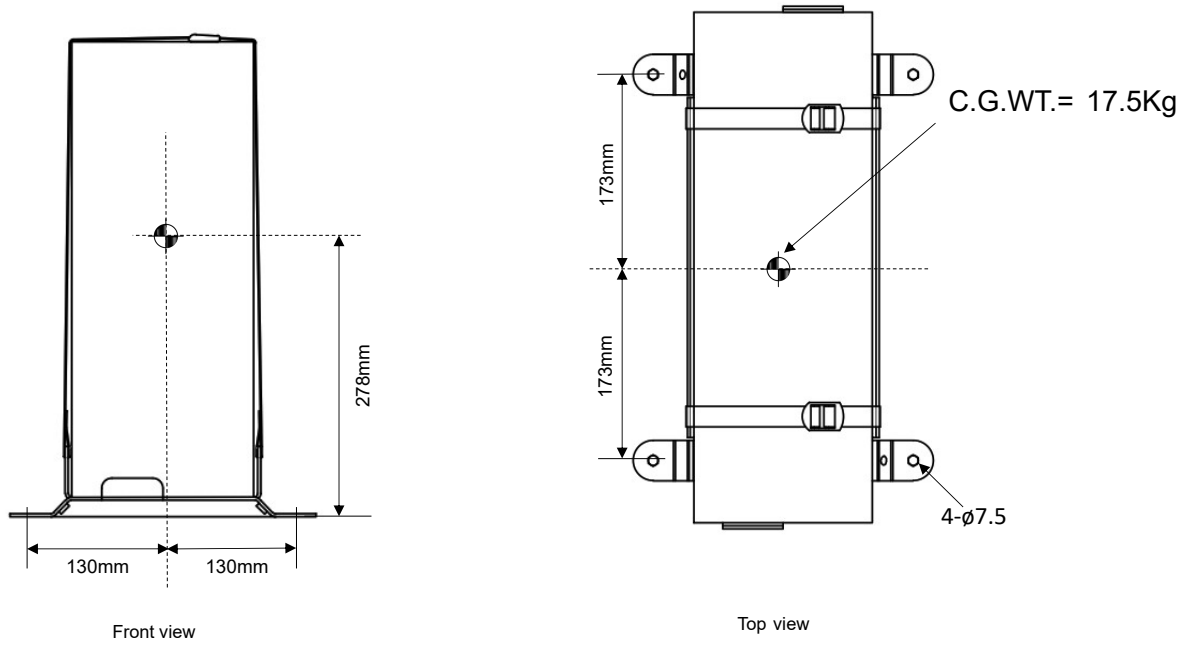
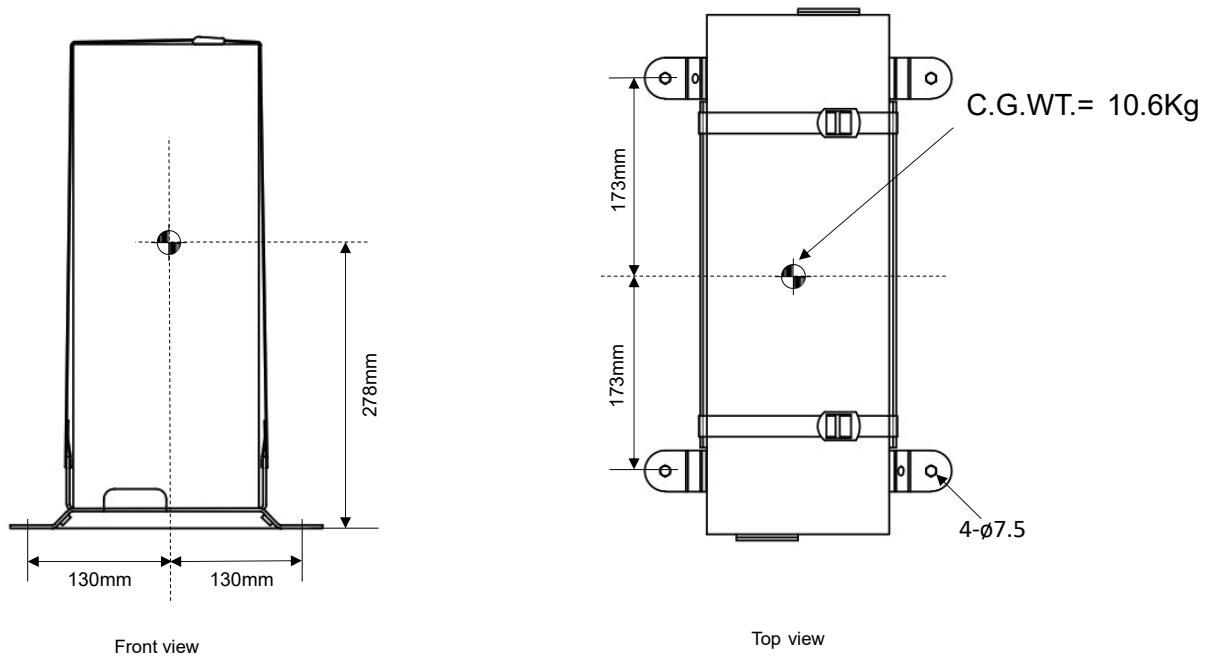

Figure 2-74 Floor Mounting Weight Z4G4 (8770000-W27): 10.6Kg max.



2.4.3.6 AP assembly

Figure 2-75 Wall mounting Weight: 0.6Kg

All mounting holes have a 4 mm diameter.

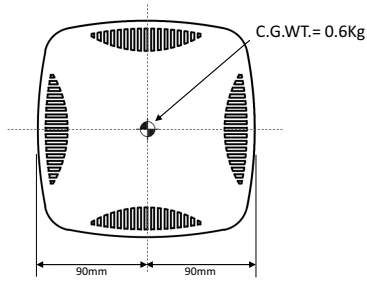

Front view

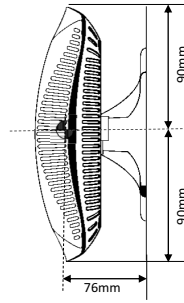

Side view

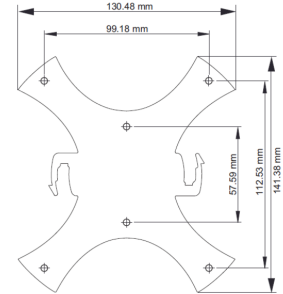

2.4.3.7 Grid box

Figure 2-76 Wall mounting Weight: 13.8Kg Totally Mechanical part, only used to store Grids

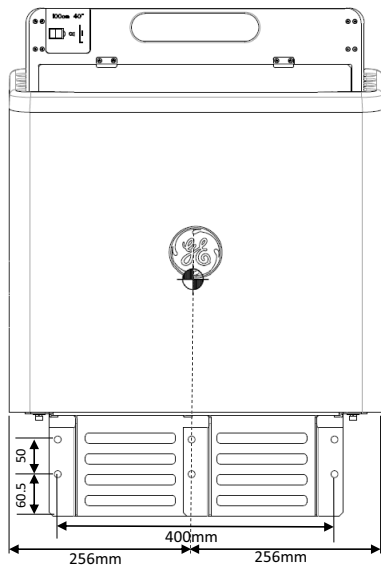

Front view

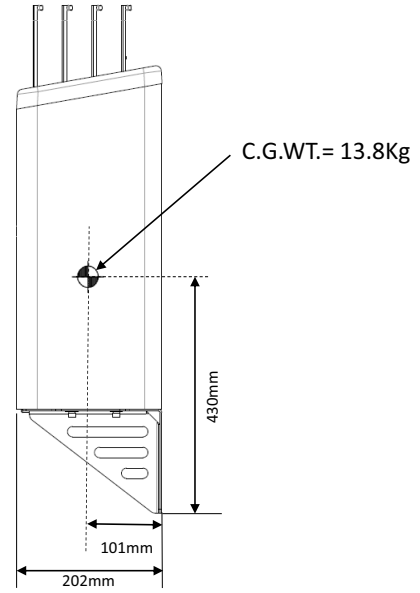

Side view

2.4.3.8 G3 wall stand GCWS-C3

Figure 2-77 Floor mounting Weight: 284kg

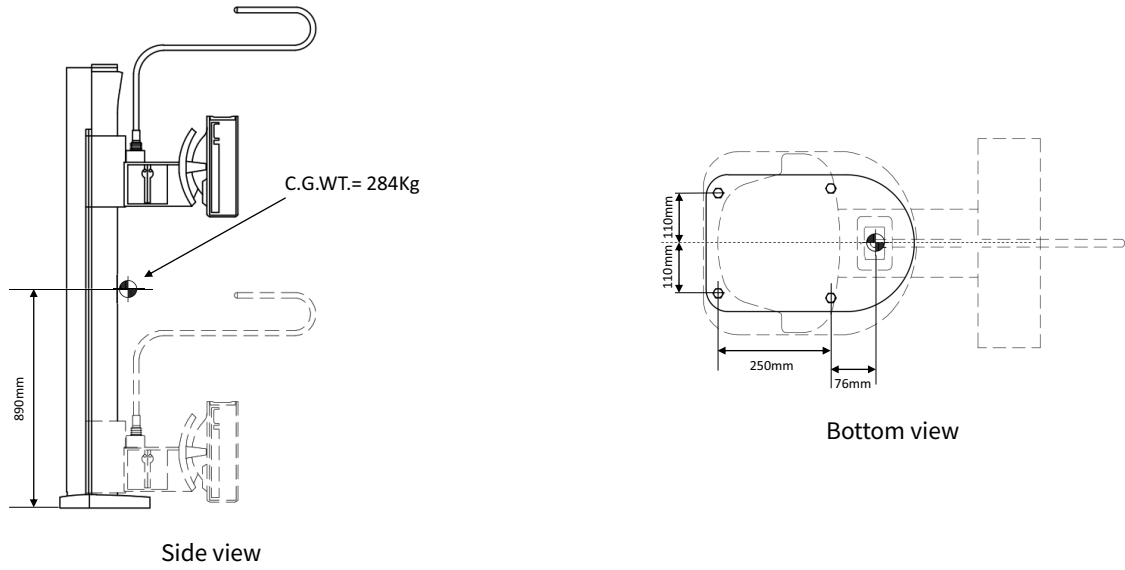

2.4.3.9 G3 extended wall stand GCEWS-C3

Figure 2-78 Floor mounting Weight: 292kg

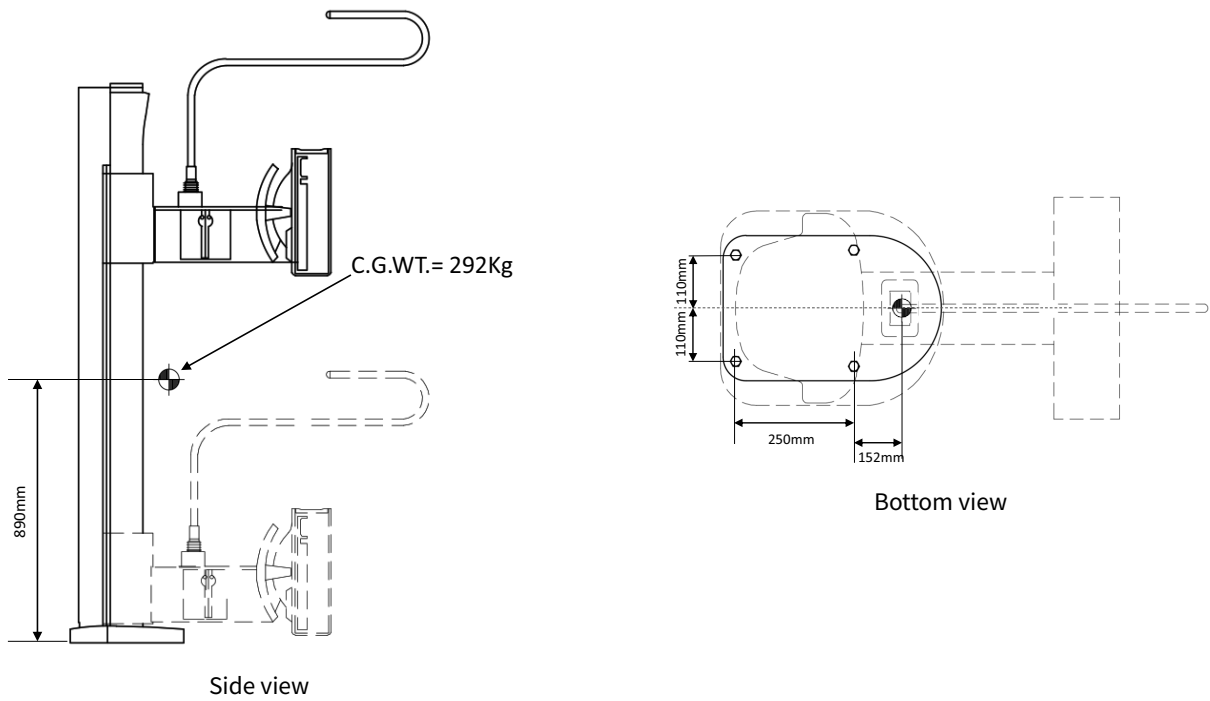

2.4.3.10 Manual Wall stand GCMWS-C5

Figure 2-79 Floor mounting Weight: 244Kg max

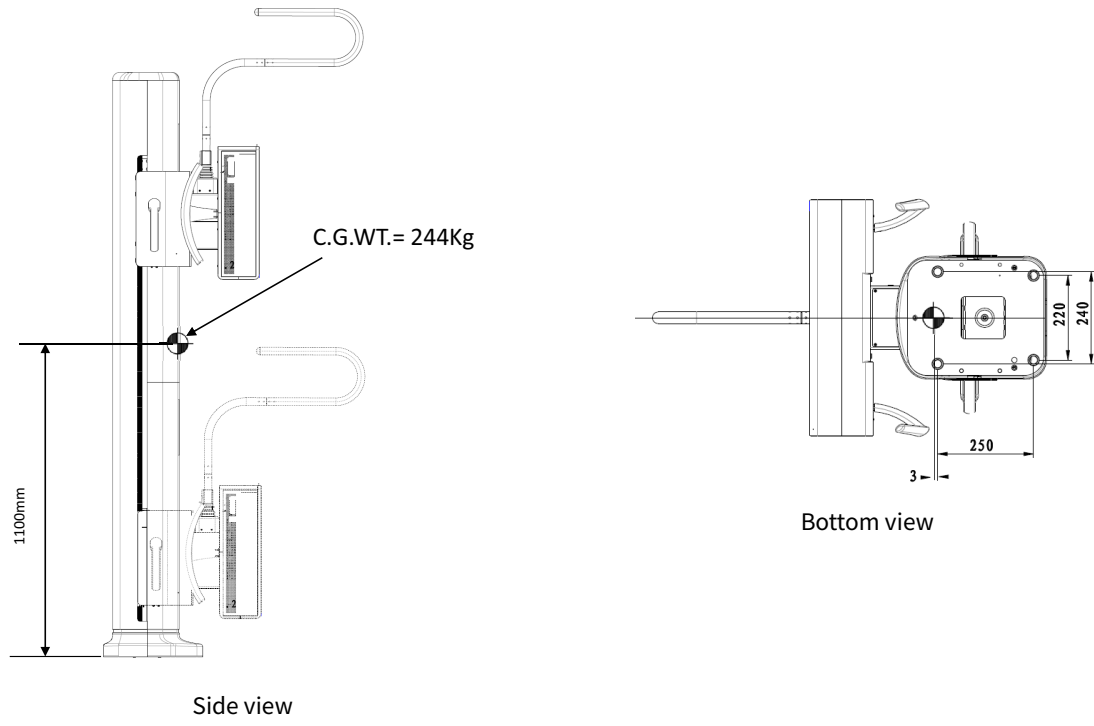

2.4.3.11 Cabinet GCC-C3

Figure 2-80 Wall Mounting Weight: 320Kg

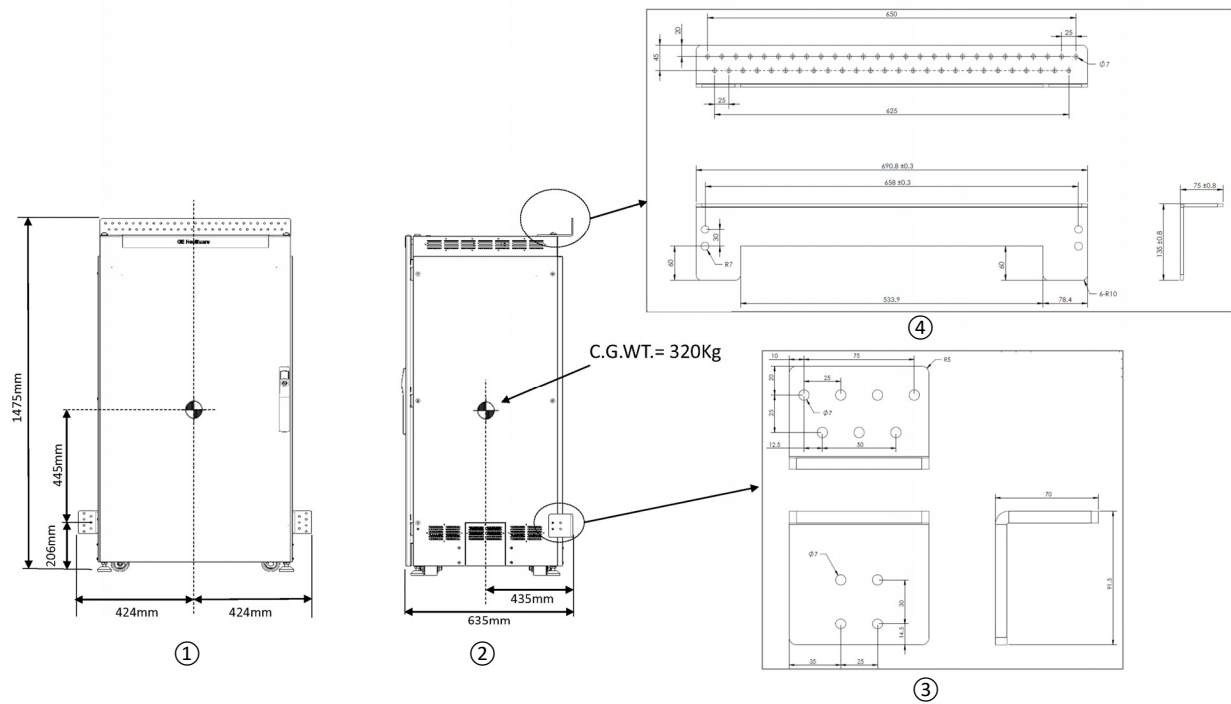

Item	Description
1	Front view
2	Side view
3	Side bracket, GE HealthCare PN 5692809, Steel, Thickness 5mm
4	Top bracket, GE HealthCare PN 5692807, Steel, Thickness 5mm

2.4.3.12 OTS with bridge

Figure 2-81 OTS 2m Bridge 5693326 and OTS 3m Bridge 5693325, Drape version

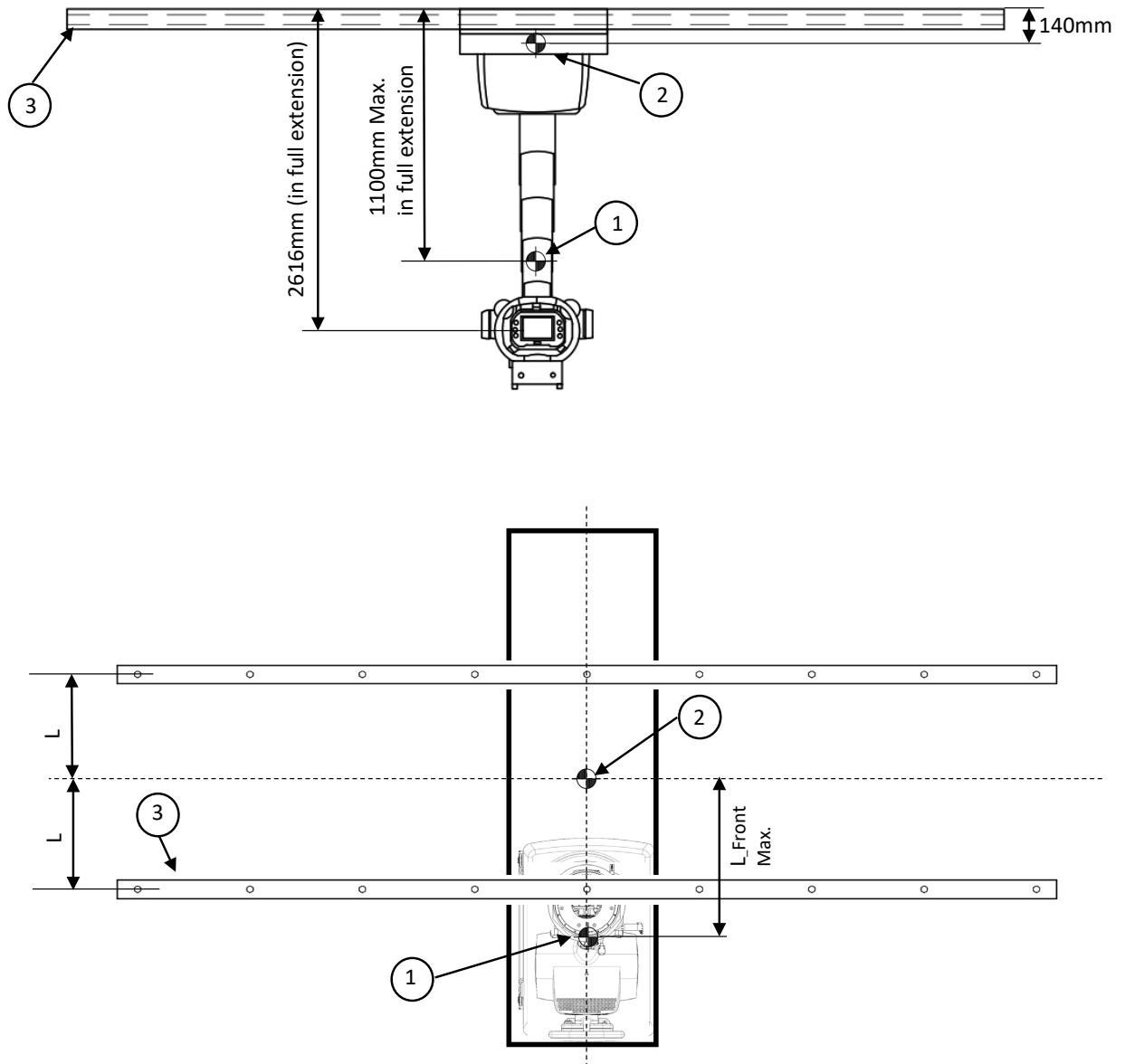

OTS at the front position of Bridge with UIF at 0°

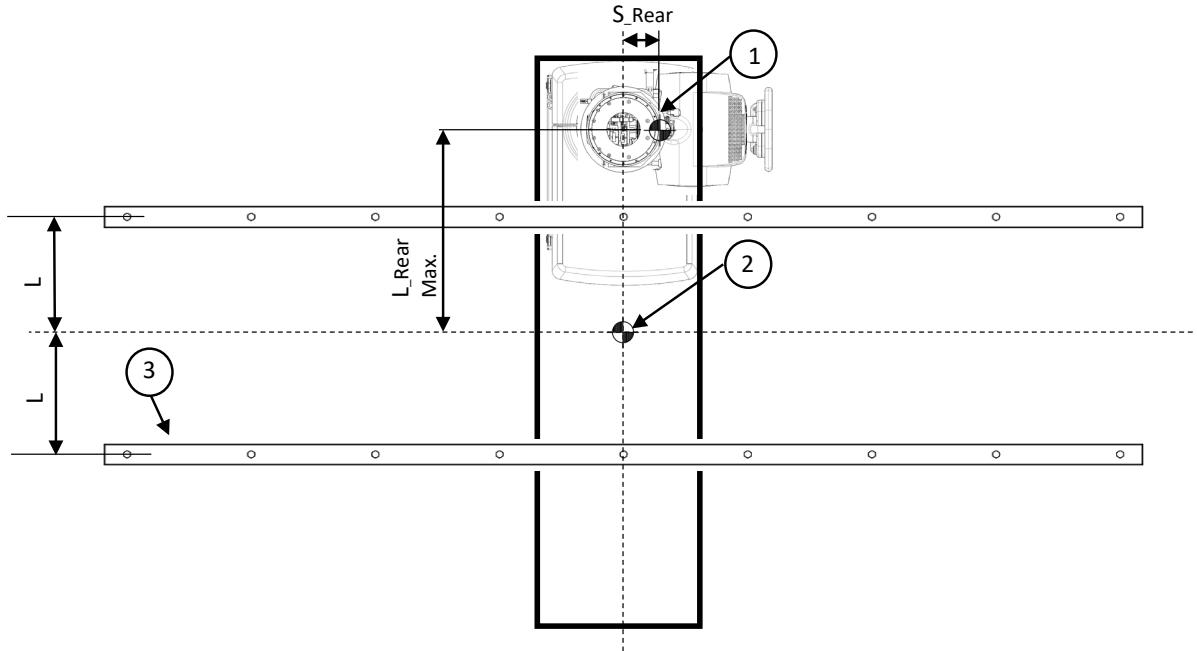

OTS at the rear position of Bridge with UIF at 90°



NOTE

OTS in full extension vertically and at the rear position of Bridge with UIF at 90° (worst case).

Description	OTS 2m Bridge	OTS 3m Bridge
① Column and Tube support	240Kg	240Kg
② Bridge	54.9Kg	63Kg
③ Longitudinal Rails	62.7Kg/5.79M	62.7Kg/5.79M
L_Front Max.	469mm	1002mm
L_Rear Max.	579mm	1112mm
S_Rear	110mm	110mm
L	711mm	711mm

Figure 2-82 OTS 2m Bridge 5693326 and OTS 3m Bridge 5693325 Cable chain version (Not seismic shake tested)

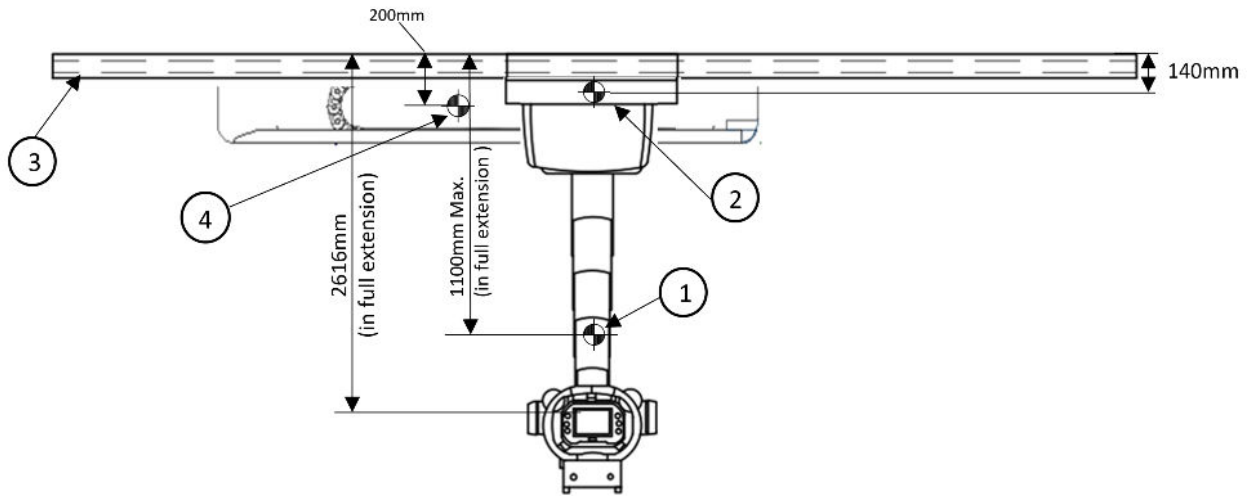

The Back bracket is fixed to ceiling separately.

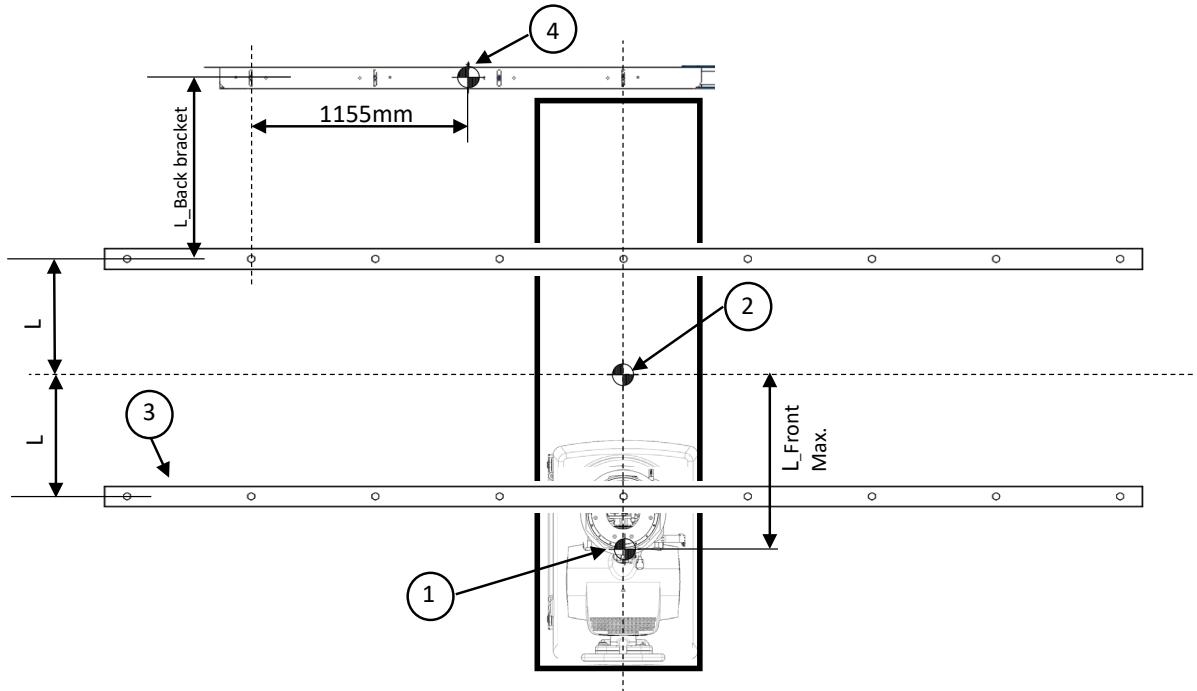

OTS at the front position of Bridge with UIF at 0°

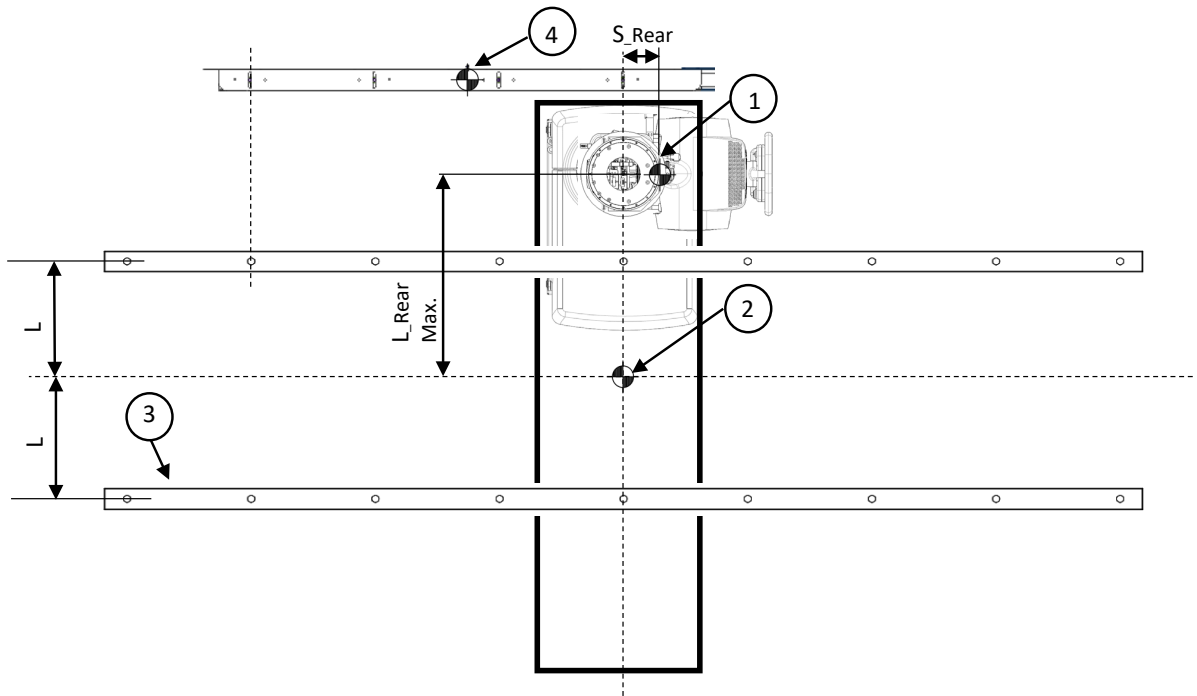

OTS at the rear position of Bridge with UIF at 90°



NOTE

OTS in full extension vertically and at the rear position of Bridge with UIF at 90° (worst case).

Description	OTS 2m Bridge	OTS 3m Bridge
① Column and Tube support + side bracket of cable chain	240Kg+20Kg	240Kg+20Kg
② Bridge	54.9Kg	63Kg
③ Longitudinal Rails	62.7Kg/5.79M	62.7Kg/5.79M
④ Back bracket of cable chain	31Kg	31Kg
L_Front Max.	469mm	1002mm
L_Rear Max.	579mm	1112mm
S_Rear	125mm	125mm
L	711mm	711mm
L_Back bracket	447mm	915mm

3 Special construction

3.1 Radiation Protection

Because X-ray equipment produces radiation, special precautions may need to be taken or special site modifications may be required. The GE HealthCare does not make recommendations regarding radiation protection. It is the purchaser's responsibility to consult a radiation physicist for advice on radiation protection in X-ray rooms.

4 HVAC

4.1 Environmental Requirements

4.1.1 Relative Humidity and Temperature

Table 4-1 Environmental Requirements (Relative Humidity and Temperature)

Product or Component	RELATIVE HUMIDITY (Non-Condensing)		Temperature	
	IN-USE		IN-USE	
	MIN	MAX	MIN	MAX
Detector	20%	75%	15° C (59° F)	32° C (89.6° F)
Wall Stand Std. and Ext.	20%	75%	15° C (59° F)	32° C (89.6° F)
Table (TBL)	20%	75%	15° C (59° F)	32° C (89.6° F)
OTS	20%	75%	15° C (59° F)	32° C (89.6° F)
System Cabinet(SKL1)	20%	75%	15° C (59° F)	32° C (89.6° F)
Maxiray 100-09 X-ray Tube	20%	75%	15° C (59° F)	32° C (89.6° F)
Radiographic Stretcher Table (optional)	20%	75%	15° C (59° F)	32° C (89.6° F)
Operator Console:				
PC	20%	75%	15° C (59° F)	32° C (89.6° F)
Monitor	20%	75%	15° C (59° F)	32° C (89.6° F)

Limits for rates of change:

In-Use	Storage
< 10 degree C / hour	< 20 degree C / hour
< 30% / hour	< 30% / hour

NOTICE

Storage values only refer to equipment in shipping containers. If the equipment is partially or completely installed, refer to In-Use values.

The operation environment is the environmental requirements for the normal use of the device during the expected service life. It does not apply to the short term manufacturing testing and the like.

4.1.2 Altitude and Atmospheric Pressure

Table 4-2 Environmental Requirements - (Altitude & Atmospheric Pressure)

PRODUCT OR COMPONENT	ALTITUDE				ATMOSPHERIC PRESSURE			
	IN-USE		STORAGE		IN-USE		STORAGE	
	MIN	MAX	MIN	MAX	MIN	MAX	MIN	MAX
Total System Limits	-30 m (-98.43 ft)	3000 m (9843 ft)	-30 m (-98.43 ft)	3000 m (9843 ft)	70 kPa	106 kPa	70 kPa	106 kPa

Limits for rates of change:

In-Use	Storage
< 1.8 kPa / hour	< 76 kPa / hour

NOTICE

STORAGE values only refer to equipment that is still in shipping containers. If the equipment is partially or completely installed, refer to IN-USE values.

The operating environment is the environmental requirements for the normal use of the device during the expected service life. It does not apply to the short term manufacturing testing and the like.

4.1.3 Non-operating Environment

4.1.3.1 Temperature

The non-operating ambient temperature range of the packaged system (except detector) shall be -20 degrees centigrade to +60 degrees centigrade.

The transportation non-operating ambient temperature range of the packaged detector shall be -5 to 50 degrees centigrade and for exceptions the shipping containers should be labeled.

The long term non-operating ambient temperature range of the detector shall be 5 to 25 degrees centigrade.

4.1.3.2 Humidity

The non-operating ambient humidity range of the packaged system shall be 10% to 85% relative humidity, non-condensing. Exceptions should have the shipping containers labeled.

4.1.3.3 Atmospheric Pressure

The non-operating ambient atmospheric pressure range of the packaged system shall be 106 kPa down to 70kPa.

4.1.3.4 Altitude

The non-operating altitude range of the packaged system shall be -30 meters up to 3000 meters to support transport at high altitude and for exceptions the shipping containers should be labeled.

4.1.4 Heat Output

The standby and in-use heat output of each system component are provided below.

Table 4-3 Heat Outputs

System Power Consumption	HEAT OUTPUT			
	STANDBY		IN-USE	
Standby Power	1.0 Kilowatt	3412 BTU/hr		
Standby Current	2.0A			
Continuous Power			2.2Kilowatt	7507 BTU/hr
Continuous Current			4.5A	

4.1.5 EMC Requirement

Refer to the Direction 5643975-1EN Optima XR646 HD Specification Chapter 2 - EMC Compliance Statement

5 Electrical

5.1 System Facility Power and Grounds

5.1.1 Introduction

The purpose of this section is to ensure that the product is properly powered and grounded, thus ensuring the proper operation of the product installed. The information in this section should be adhered to, unless there are written deviations approved by GE HealthCare.

This section gives the sizes and procedures on how to power and ground your system. If these power and grounding instructions are not adhered to, proper operation cannot be guaranteed. Any cost associated and found to be a result of non-conformity, as stated in this section, may result in additional cost charged back to the institution and/or their contractor.

NOTICE

All system and sub-system power connections shall be made ONLY to power outlets that are connected to the system.

5.1.2 Power Quality

The electrical power, from its origination to the system, must adhere to the wire size and transformer sizes as prescribed in the installation drawings. The feeder voltage-drops, as well as the supplying power, must be within the given parameters. Sizing for feeder is usually calculated for a maximum of 2% voltage drop at the minimum voltage range. The actual feeder sizing may vary from the installation drawing for a facilities voltage.

Calculate feeder losses before you begin. Total feeder losses must be calculated to ensure that the losses are less than those specified in the installation drawings. Calculating the recommended minimum transformer sizing for feeding a system ensures the transformer losses are less than half of the maximum regulation for the system.

Regulation is the calculated voltage losses for the entire power distribution system (No-Load Voltage minus Full-Load Voltage) divided by the no-load voltage minus the system losses (Full- Load Voltage):

$$\text{Regulation} = \frac{\text{NoLoadVoltage} - \text{FullLoadVoltage}}{\text{FullLoadVoltage}} \times 100$$

In the X-ray room, there must be a lockable facility power disconnect. It must be installed electrically before the equipment, for the purpose of locking out the power. This must be done before service to the high voltage system is performed.

5.1.3 Electrical Grounds

5.1.3.1 System and Facility Grounds

The ground for this system must originate at the system’s power source and be continuous (i.e., transformer or first access point of power into a facility, and be continuous to the system power disconnect in the room). Ground connection at the power source must be at the grounding point of the “Neutral/Ground” if a “Wye” transformer is used, or typical grounding points of a separately derived system. In the case of an external facility, it must be bonded to the facility ground point at the electrical service entrance.

The “system” ground can be spliced using “High Compression Fittings” but must be properly terminated at each distribution panel it passes through. When it is terminated, it must be connected into an approved grounding block. Incoming and outgoing grounds must terminate at this same grounding block. Grounds must only be terminated to approved grounding blocks. Grounds must never connect directly to the panels, frames or other materials in a cabinet or distribution panel.

5.1.3.2 Recommended Ground Wire Sizes

The ground wire impedance from the system disconnect (including the ground rod) measured to earth, must not exceed 2 ohms (as measured by one of the applicable techniques described in Section 4 of ANSI/IEEE Standard 142 - 1982).

NOTE

For general system grounding requirements and information on establishing an equipotential grounding system, refer to:

- Direction 46-014505, Electrical Safety - Equipment Grounding
- Direction 46-014546, Electrical Safety - Leakage Currents

5.2 Electrical Requirements

5.2.1 Generator Electrical Requirements

All system components obtain their power from the Power Distribution Unit (PDU) in the System Cabinet. **Providing power and ground wires to the PDU are the responsibility of the customer.** As an aid, wire sizes for various lengths of the power supply cable are shown in the following tables.

NOTE

The length of stripped wires should be longer than 25 mm (1in), and tinned.

NOTE

Shunt trip circuit breaker required. The main circuit breaker supplied by the customer must be sized in accordance to local regulations.

Generator Power Specifications

Table 5-1 JEDI Generator Power Specifications

Input Voltage	380/400/415/440/460/480 VAC Wye 3-Phase and ground without neutral
Daily Voltage variations	+/- 10% (VAC) In this range, the generator will operate without any de-rating in accuracy

Table 5-1 JEDI Generator Power Specifications (Table continued)

Nominal line frequency (Hz)	50 Hz / 60 Hz																											
Daily frequency variation (Hz)	+/- 3 Hz																											
Line Impedance	<p>The apparent line impedance guaranteed by the customer should be equal or less than the values indicated below, according to the voltage value and the commercial power of the system.</p> <p>Voltage range (V) Line Impedance (ohms)</p> <table border="1"> <thead> <tr> <th>3 phase</th> <th>50kW</th> <th>65kW</th> <th>80kW</th> </tr> </thead> <tbody> <tr> <td>380</td> <td>0.15</td> <td>0.118</td> <td>0.096</td> </tr> <tr> <td>400</td> <td>0.16</td> <td>0.131</td> <td>0.100</td> </tr> <tr> <td>415</td> <td>0.18</td> <td>0.138</td> <td>0.113</td> </tr> <tr> <td>440</td> <td>0.20</td> <td>0.154</td> <td>0.125</td> </tr> <tr> <td>480</td> <td>0.24</td> <td>0.185</td> <td>0.150</td> </tr> </tbody> </table> <p>NOTE 400-480 VAC impedance values are based on IEC 601-2-7 standard. Values are interpolated from values in standard.</p>				3 phase	50kW	65kW	80kW	380	0.15	0.118	0.096	400	0.16	0.131	0.100	415	0.18	0.138	0.113	440	0.20	0.154	0.125	480	0.24	0.185	0.150
3 phase	50kW	65kW	80kW																									
380	0.15	0.118	0.096																									
400	0.16	0.131	0.100																									
415	0.18	0.138	0.113																									
440	0.20	0.154	0.125																									
480	0.24	0.185	0.150																									
Inrush current	1000 Amps. Genetrator needs a 165Amps and the fuse is a part of PDU. 1000Amps is rating at 3 phase at system I/P, for generator 1000Amps current may not be required. The max current raquired for generator is during start-up (capacitor changing) and during peak power exposure for long durationns.																											
HV cable type	USA: 22mm DSI (<= 165 pF/m) HV cable connector = Federal standard																											
Ground Wire	Same as power cable																											

5.2.2 System Wire Sizes & kVA Load Characteristics

- Calculations based upon nominal voltage, wire size in AWG. To convert to mm², refer to [Table 5-2](#).
- Recommended feeder sizes from distribution transformer to the power cabinet.
- Neutral must be terminated inside the main disconnect panel and not at any GE HealthCare cabinet.
- The grounding conductor will be of same size as the feeder wires. This ground will run from equipment back to the facility power source / main grounding point and always travel in the same conduit with the feeders and neutral.

Table 5-2 AWG Wire Size Conversion to mm²

American Wire Gauge (AWG)	Diameter (Inches)	Diameter (mm)	Cross Sectional Area (mm ²)
6	0.1620	4.11	13.30
5	0.1819	4.62	16.77
4	0.2043	5.19	21.15
3	0.2294	5.83	26.65

Table 5-2 AWG Wire Size Conversion to mm² (Table continued)

American Wire Gauge (AWG)	Diameter (Inches)	Diameter (mm)	Cross Sectional Area (mm ²)
2	0.2576	6.54	33.61
1	0.2893	7.35	42.39
1/0	0.3249	8.25	53.46
2/0	0.3648	9.27	67.40
3/0	0.4096	10.40	84.97
4/0	0.46	11.68	107.16
250M	0.575	14.6	126.68
300M	0.630	16.0	152.0
350M	0.681	17.3	177.35
400M	0.728	18.49	202.68

5.2.2.1 JEDI Generator 3-Phase 50 kW System - Minimum Wire Size

WIRE RUN LENGTH	INPUT VOLTAGE (VAC)					
	380	400	420	440	460	480
	+/- 10%	+/- 10%	+/- 10%	+/- 10%	+/- 10%	+/- 10%
15m (50 ft.)	*6	*6	*6	*6	*6	*6
30m (100 ft.)	5	5	*6	*6	*6	*6
46m (150 ft.)	4	4	4	4	4	4
61m (200 ft.)	3	4	4	4	4	4
77 m (250 ft)	2	2	2	3	3	4
92 m (300 ft)	1/0	1	1	2	2	2
107m (350ft)	2/0	2/0	1/0	1	1	1
122m (400 ft)	3/0	2/0	2/0	1/0	1/0	1/0
138m (450 ft)	4/0	3/0	3/0	2/0	2/0	1/0

* minimum wire size for circuit breaker, based on recommended overcurrent protection.

5.2.2.2 kVA Load Characteristics 50KW

Table 5-3 kVA Load Characteristics 50KW

Phase	THREE PHASE					
Nominal Line Voltage (Vac)	380	400	420	440	460	480
Voltage Range (Vac)	+/- 10%	+/- 10%	+/- 10%	+/- 10%	+/- 10%	+/- 10%
Momentary Line Current (Amp)	110	105	100	95	92	88
Continuous Line Current (Amp)	7	6.7	6.2	6	5.7	5.5
Power Demand (kVA)	70	70	70	70	70	70
Frequency	47/53Hz and 57/63Hz					

5.2.2.3 JEDI Generator 3-Phase 65 kW and System - Minimum Wire Size

Table 5-4 JEDI Generator 3-Phase 65 kW System - Minimum Wire Size

WIRE RUN LENGTH	INPUT VOLTAGE (VAC)					
	380	400	420	440	460	480
	+/- 10%	+/- 10%	+/- 10%	+/- 10%	+/- 10%	+/- 10%
15m (50 ft.)	*4	*4	*4	*4	*4	*4
30m (100 ft.)	3	*4	*4	*4	*4	*4
46m (150 ft.)	2	2	2	3	3	*4
61m (200 ft.)	1/0	1	1	2	2	2
77 m (250 ft)	2/0	2/0	1/0	1	1	1
92 m (300 ft)	3/0	2/0	2/0	1/0	1/0	1/0
107m (350ft)	4/0	3/0	3/0	2/0	2/0	1/0
122m (400 ft)	250M	4/0	4/0	3/0	3/0	2/0
138m (450 ft)	300M	250M	4/0	4/0	3/0	3/0

* minimum wire size for circuit breaker, based on recommended overcurrent protection.

5.2.2.4 kVA Load Characteristics 65KW

Table 5-5 kVA Load Characteristics 65 kW

Phase	THREE PHASE					
	380	400	420	440	460	480
Nominal Line Voltage (Vac)	380	400	420	440	460	480
Voltage Range (Vac)	+/- 10%	+/- 10%	+/- 10%	+/- 10%	+/- 10%	+/- 10%
Momentary Line Current (Amp)	147	140	133	127	122	117
Continuous Line Current (Amp)	7	6.7	6.2	6	5.7	5.5
Power Demand (kVA)	97	97	97	97	97	97
Frequency	47/53Hz and 57/63Hz					

5.2.2.5 JEDI Generator 3-Phase 80 kW and System - Minimum Wire Size

Table 5-6 JEDI Generator 3-Phase 80 kW System - Minimum Wire Size

WIRE RUN LENGTH	INPUT VOLTAGE (VAC)					
	380	400	420	440	460	480
	+/- 10%	+/- 10%	+/- 10%	+/- 10%	+/- 10%	+/- 10%
15m (50 ft.)	*2	*2	*2	*2	*2	*2
30m (100 ft.)	*2	*2	*2	*2	*2	*2
46m (150 ft.)	1/0	1	1	*2	*2	*2
61m (200 ft.)	2/0	2/0	1/0	1/0	1	1
77 m (250 ft)	3/0	3/0	2/0	2/0	1/0	1/0
92 m (300 ft)	4/0	4/0	3/0	3/0	2/0	2/0

Table 5-6 JEDI Generator 3-Phase 80 kW System - Minimum Wire Size (Table continued)

WIRE RUN LENGTH	INPUT VOLTAGE (VAC)					
	380	400	420	440	460	480
	+/- 10%	+/- 10%	+/- 10%	+/- 10%	+/- 10%	+/- 10%
107m (350ft)	300M	250M	4/0	4/0	3/0	3/0
122m (400 ft)	350M	300M	250M	4/0	4/0	3/0
138m (450 ft)	400M	350M	300M	250M	250M	4.0

* minimum wire size for circuit breaker, based on recommended overcurrent protection.

5.2.2.6 kVA Load Characteristics 80KW

Table 5-7 kVA Load Characteristics 80 kW

Phase	THREE PHASE					
Nominal Line Voltage (Vac)	380	400	420	440	460	480
Voltage Range (Vac)	+/- 10%	+/- 10%	+/- 10%	+/- 10%	+/- 10%	+/- 10%
Momentary Line Current (Amp)	190	180	170	163	156	150
Continuous Line Current (Amp)	7	6.7	6.2	6	5.7	5.5
Power Demand (kVA)	125	125	125	125	125	125
Frequency	47/53Hz and 57/63Hz					

5.2.3 Recommended Wall Circuit-Breaker Ratings

Table 5-8 Wall Breaker Parameter (Theoretical Current Values)

Power / Voltage	50 kW	65 kW	80 kW
380 V	55 A / 600 V	74 A / 600 V	95 A / 600 V
400 V	52 A / 600 V	70 A / 600 V	90 A / 600 V
415 V	50 A / 600 V	67 A / 600 V	85 A / 600 V
440 V	47 A / 600 V	64 A / 600 V	82 A / 600 V
460 V	45 A / 600 V	61 A / 600 V	78 A / 600 V
480 V	43 A / 600 V	59 A / 600 V	75 A / 600 V

5.2.4 Wiring Electrical Power and Disconnects

This section provides additional data regarding power circuits the customer must provide, and internal electrical circuits necessary to supply the correct power to the system. [Figure 5-1](#) shows the room power supply installed.

5.2.4.1 Room Power Supply

Figure 5-1 Room Power Supply (refer to Table 5-9 for Legend)

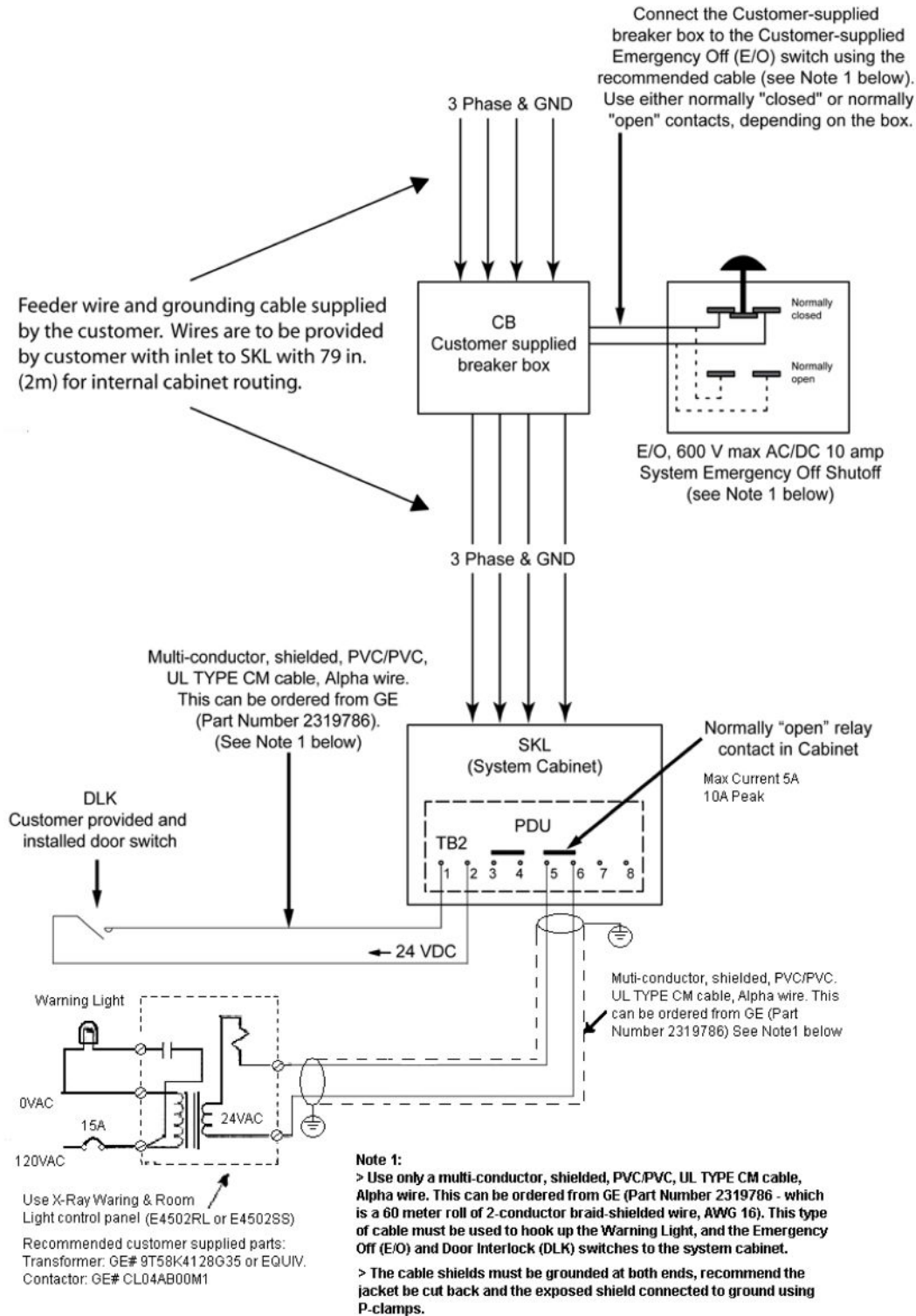

Table 5-9 Legend for the above figure

United States Key	Description
Feeder Wires and Grounding Cable	Feeder wire and grounding cable supplied by the customer. Wires are to be provided by customer with inlet to SKL with 2 meters for internal cabinet routing).
E/O (see Note below)	Emergency Off switch located near room access door. The switch is supplied by the Hospital. The recommended distance above the floor is 1.5 meters. Use only a multi-conductor, shielded cable to connect to System Cabinet.
XRL	Yellow X-ray emission indicator lamp above the room access door. 220 V in Europe/120 V in USA with 25 W max. bulb (per local regulations). Wires and light fixtures supplied by customer.
DLK (see Note below)	Open-door detector (per local regulations). SKL provides 24 VDC.
CB	Circuit breaker with remote trip (shunt) capabilities supplied by customer.

NOTE

Use only a multi-conductor, shielded, PVC/PVC, UL TYPE CM cable, Alpha wire. The cable shield must be grounded at both ends. With the system cabinet grounding, avoid make wireless transmission unintelligible by causing interference.

5.2.4.2 Multiple Emergency OFF Switches

The facility designer determines the quantity and locations of the Emergency OFF (E/O) switches. GE HealthCare recommends placing at least one Emergency OFF switch near the doorway of every room in the system scan suite.

Figure 5-2 Wiring Multiple "Emergency OFF" (E/O) Switches

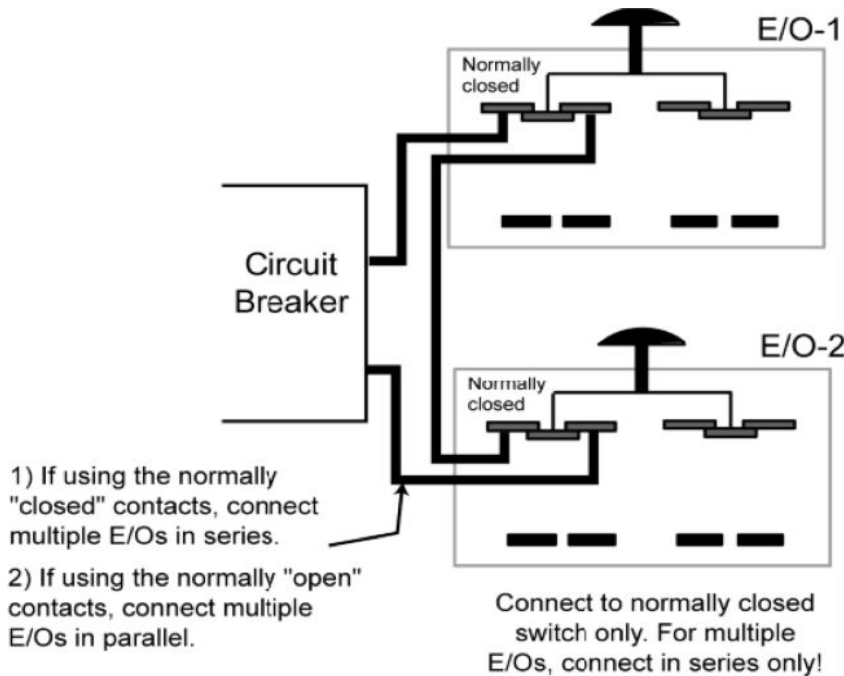

5.3 Routing Cables

5.3.1 General

These wires must be kept separated from each other:

- High voltage and power cables must be separated from other cables
- Separate conduits must be used for power and signal wires

Use a separate trough in the duct system, or use a separate conduit.

Minimize cable length between the line disconnect and the System Cabinet power unit to reduce voltage regulation problems and wiring costs.

5.3.1.1 Electrical Ducts (Recommended)

It is important that electrical ducts have separate compartments for power and signal wires. These wires must be kept separated from each other for proper system operation.

Electrical ducts have advantages, when used with a single room or two adjacent rooms. Electrical ducts combine cabling in a neat and functional appearance, with accessibility and room for expansion.

5.3.1.2 Conduit

If conduit is used make sure the conduit is large enough to pull the cable and connector through with all the other cables all ready in the conduit.

The use of conduit is recommended for cables running overhead between rooms, especially when a diagonal run provides the shortest cable path.

5.3.2 Power Distribution

The system power distribution consists of two major components that must either be customer supplied or GE HealthCare supplied. These are:

- Feeder power from Hospital distribution center to the System Cabinet load power unit (SKL).
- Feeder power must be provided via a WYE transformer only with dedicated ground. Neutral is not used.
- Power distribution from the System Cabinet load power unit (SKL) to all the components in the system room.

Usually the feeder power from the Hospital distribution center is customer supplied and the power distribution within the system is supplied by GE HealthCare.

5.4 Light Specification

The monitor screen is adjusted for an optimum ambient light level of 50 lux.

5.5 Dimensioned Figures and Drawings

5.5.1 Wall Box (if applicable)

NOTE

The use of a wall box is required with this system. Wall box is used to interface the cables in exam room and patient room. Wall box shall be installed on the wall, that can't be placed on the ground. The cables used with this system are terminated with connectors that can only be used with this specific wall box.

The wall box will fit best over a 370 x 170 mm (14.6 x 6.7 in) x 4" wall box (installed by electrical contractor).

Figure 5-3 Wall box Dimensions 370 mm X 170 mm X (14.6in x 6.7in)

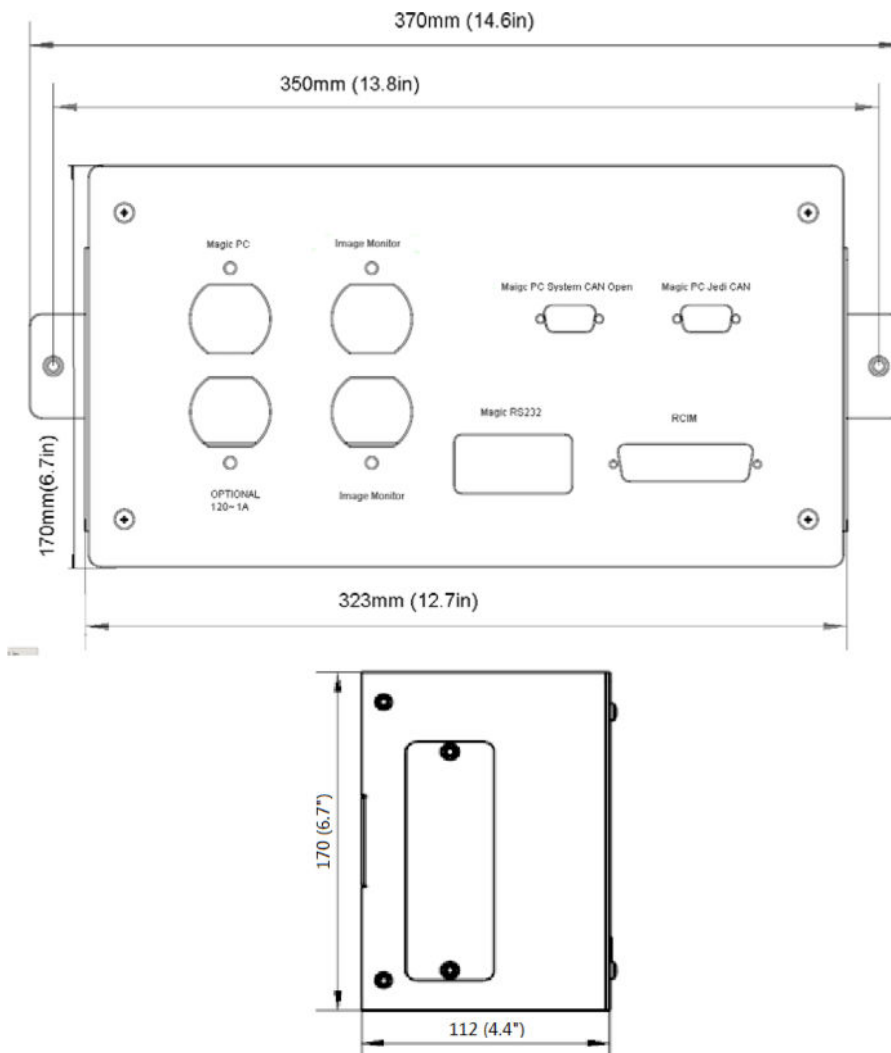

5.5.2 System Equipment Cable Entrance

Figure 5-4 System Cabinet Cable Entrances

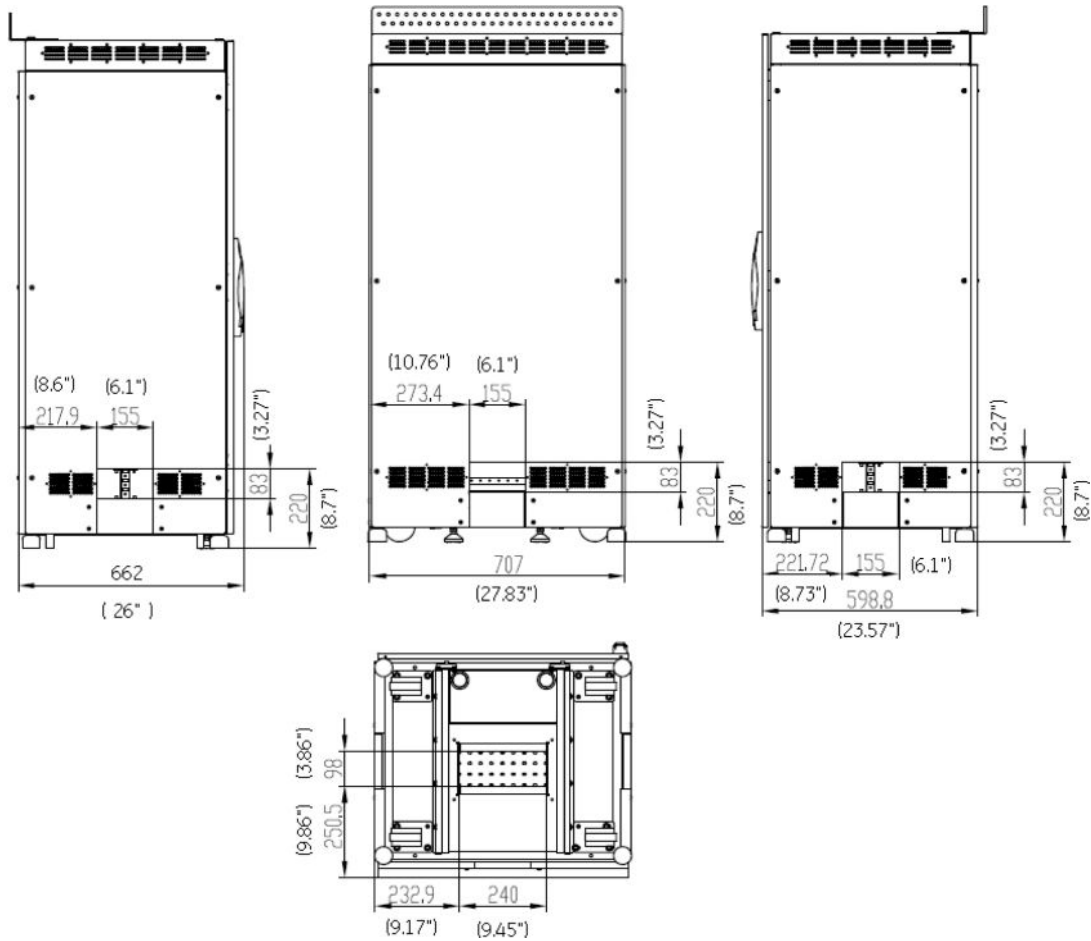

Figure 5-5 VCP Cabinet Cable Entrance

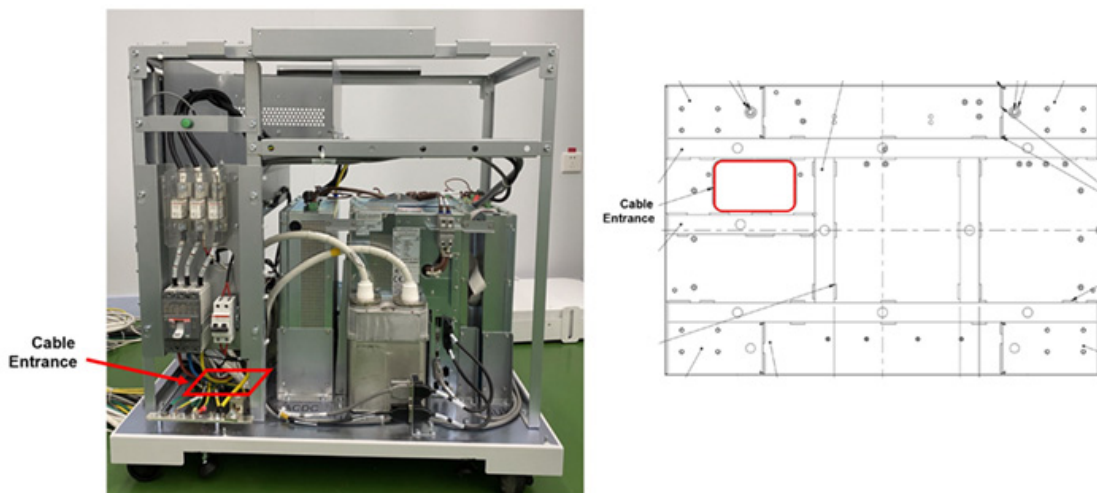
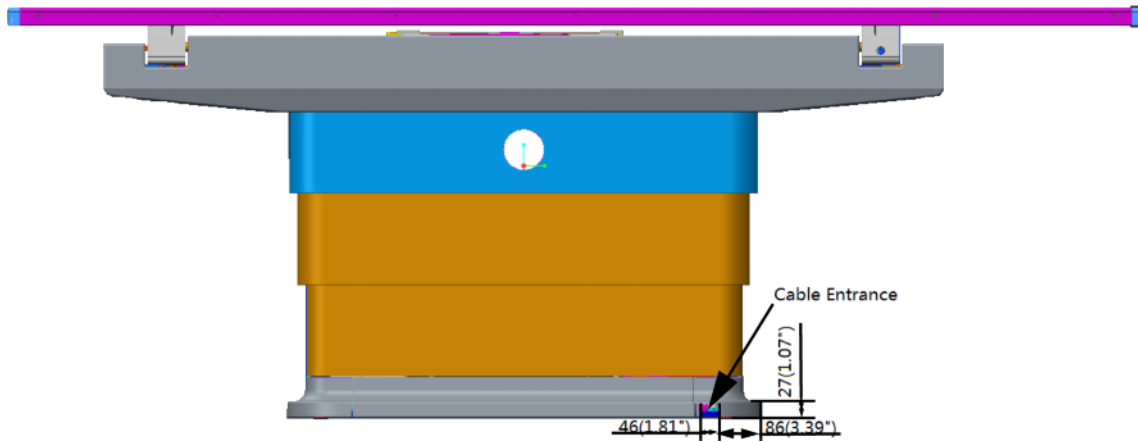

Figure 5-6 Global G3Table Cable Entrance



There are two cable entrances, the cable entrance of on the back side usually is for the cables on the floor, the cable entrance of on the table base usually is for raceway.

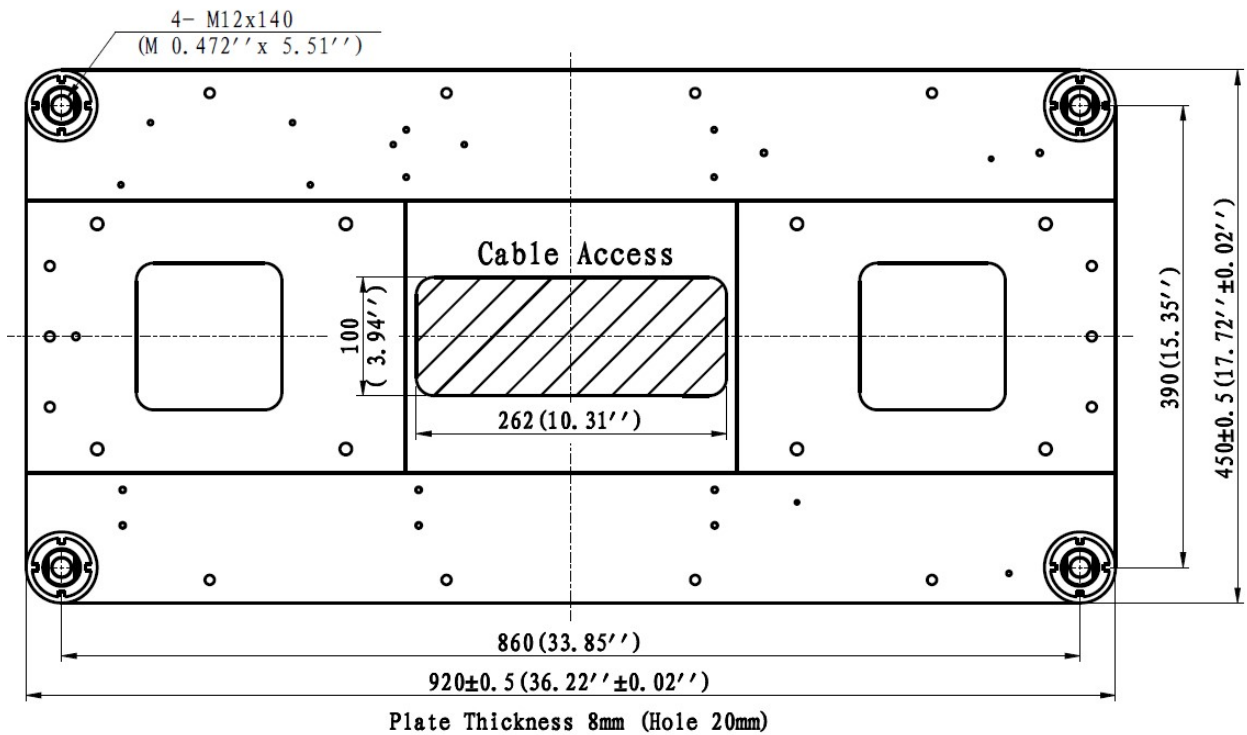

Table Base View

Figure 5-7 Global G3 Std Table Cable Entrance

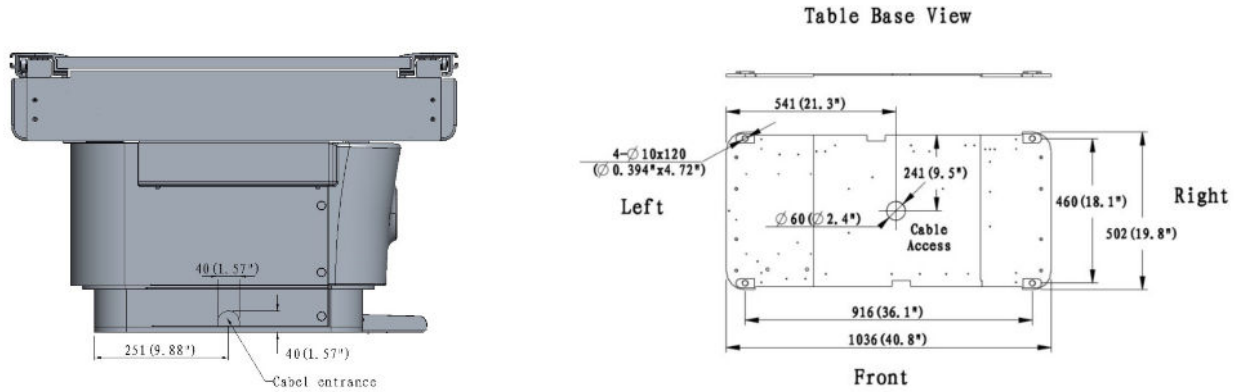
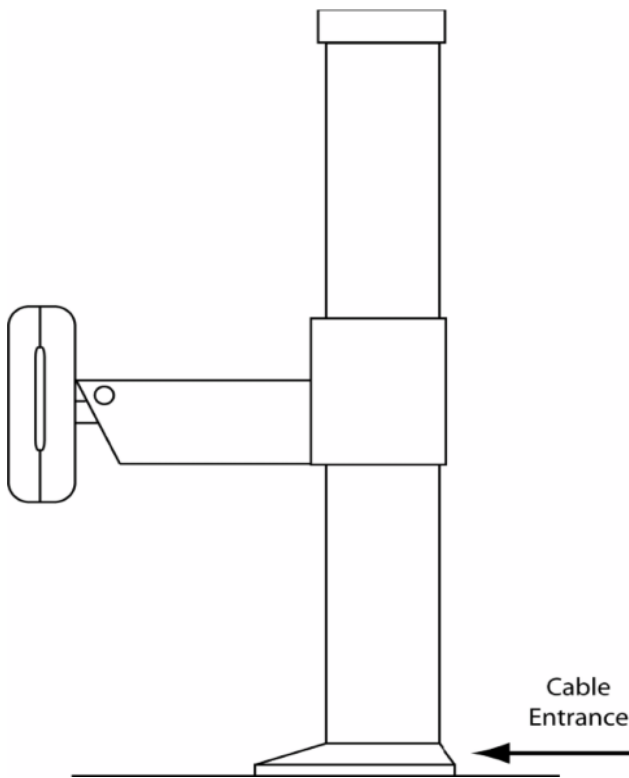

Figure 5-8 Wall Stand Cable Entrance



5.5.3 Power and cables requirements for TIB

The System cabinet distribute the power 120VAC to TIB J1 through PN#5402662 and TIB Ground cable PN# 5789055, TIB output 15VDC by tether cable PN# 5736526 to Detector and Tether Ethernet cable PN# 5777037 to PC. See System MIS Map.

Figure 5-9 TIB Power input and output

J1: 120VAC Input

5.5.4 Power and cables requirements for Chargers BIN

Need a 110/220VAC power distribute by hospital and two Ethernet cables connect to PC. See System MIS Map.

6 Communications/Networking

6.1 Hospital Network

6.1.1 Broadband Network Connection

The system is equipped with Broadband fast Ethernet hardware for Service diagnostics. Systems equipped with Digital Imaging are capable of placing electronic images on the Hospital image Ethernet Network. It is the purchasers responsibility to provide the Ethernet connection (rated at 100Mb/sec transfer rate for optimal performance) within 3 feet (0.91 meters) of the Operator Console.

The network connection is made at the Operator Console.

- 100BaseT network connection is preferred
- 10BaseT network connection is acceptable

NOTE

If using GE PACS LITE BOX software, the GE PACS LITE BOX software revision must be 6.1d02 or greater. Older versions will not work with the system.

NOTE

1. Connection of the product to a network that includes other equipment could result in previously unidentified risks to patients, operators or third parties;
2. The responsible organization should identify, analyze, evaluate and control these risks;
3. Subsequent changes to the network could introduce new risk and require additional analysis; and
 - Changes to the network include:
 - Changes in network configuration;
 - Connection of additional items to the network;
 - Disconnecting items from the network;
 - Update of equipment connected to the network;
 - Upgrade of equipment connected to the network.

NOTE

The means required to present the images for diagnostic purpose shall comply with the requirements of DICOM standards.

6.1.2 Phone Line(s) - Voice

It is recommended that phone line(s) be installed within 3 feet (0.91 meters) of the Operator Console and be operational prior to installation.

6.1.3 Remote Services Broadband Pre-Installation Requirements for Europe

- To enable an easier installation and to benefit from remote support (service and engineering teams), equipment should be Insite connected at installation.
- Thus the connectivity solution to implement should be decided during pre installation and all related data should be available before installation starts.
- For all installations make sure that you have at least one RJ45 dedicated to connect the new equipment on the LAN. In case of Broadband, this connection will also be used for the remote service of the equipment.
- GE HealthCare offers a wide range of connectivity solutions: From full GE HealthCare package (GE HealthCare supplies Router and customer buys the line) to customized solutions (GE HealthCare adapts to customer infrastructure).
- Network devices (like CISCO Routers for instance) can be shipped with the equipment only if the Sales Representative has added the connectivity item in the order.
- For complete descriptions of these connectivity solutions, please refer to the Broadband Solutions catalogue available through your local GE HealthCare sales and service representative.
- Connectivity Process and pre-installations checklists are available in the Broadband Connectivity Pre-Installation Manual (PIM) available through your local GE HealthCare sales and service representative.
- For each solution selected by the customer the pre-installation checklist must be fulfilled by site IT manager in order to get connectivity information (site IT manager contacts, IP address...) available at installation.

NOTE

Connection of the product to a network that includes other equipment could result in previously unidentified risks to patients, operators or third parties;

- The responsible organization should identify, analyze, evaluate and control these risks;
- Subsequent changes to the network could introduce new risk and require additional analysis; and
 - Changes to the network include;
 - Changes in network configuration;
 - Connection of additional items to the network;
 - Disconnecting items from the network;
 - Update of equipment connected to the network;
 - Upgrade of equipment connected to the network.

6.2 Networkflow Audit

Understanding how your facility leverages its network investment through our Networkflow process will help us better integrate the system into your operations. The following is intended to identify the various ways the system can fit into your workflow and the ramifications of selecting one path or another. We would like to start at the beginning, with the patient arriving at your facility, going

through registration/admittance/patient scheduling and proceed all the way to the read images being archived.

6.2.1 What is the Networkflow Audit

This audit was designed to collect information on your network, your DICOM equipment, your workflow and your dataflow. Once this information is collected, it will be used to determine the best way the system can fit into your facility. The information will also be used to ease and speed the integration of the system into your facility .This audit is intended to be performed before the system is quoted to you. With all facts uncovered, GE HealthCare can prepare a more accurate quote and minimize "surprises" at the time of install.

You should fill this out with the GE HealthCare representative. They will be able to answer any questions you may have.

6.2.2 Facility Information

- | | |
|--|----------------------------------|
| <input type="checkbox"/> Name of facility: | <input type="checkbox"/> Room #: |
| <input type="checkbox"/> Workflow contact: | <input type="checkbox"/> Phone: |
| <input type="checkbox"/> Network Infrastructure contact: | <input type="checkbox"/> Phone: |
| <input type="checkbox"/> DICOM Device contact: | <input type="checkbox"/> Phone: |
| <input type="checkbox"/> Other contact: | <input type="checkbox"/> Phone: |
| <input type="checkbox"/> GE HealthCare Sales Representative: | |
| <input type="checkbox"/> GE HealthCare Auditor: | |

6.2.3 Workflow Analysis

When the patient arrives in the system room for the exam, how is the patient data entered into the system?

<input type="checkbox"/> Manually typed	<input type="checkbox"/> Entered via barcode reader Barcode format:_____	<input type="checkbox"/> Downloaded from HIS/RIS
---	---	--

If the patient information was downloaded from a HIS/RIS system, how would the query be structured? (Pick all that apply)

<input type="checkbox"/> By date	<input type="checkbox"/> By modality	<input type="checkbox"/> By patient information
<input type="checkbox"/> Other method - Please explain:	_____	

In retrieving patient schedule information, do you query

<input type="checkbox"/> Once at the start of the shift	<input type="checkbox"/> Several times during a shift	<input type="checkbox"/> Before each patient
---	---	--

What percent of images acquired are reviewed via softcopy? _____%

What percent of images acquired are printed? _____%

Once the digital diagnostic images are acquired, what is your facility's default workflow? (Pick one)

<input type="checkbox"/> Manually send	<input type="checkbox"/> Automatically push
--	---

(Pick all that apply)

<input type="checkbox"/> Review station(s)	<input type="checkbox"/> Archive system(s)	<input type="checkbox"/> Printer(s)
--	--	-------------------------------------

When images are configured for automatic push, what would you like to be sent to PACS/archive/review stations?

<input type="checkbox"/>	Raw	<input type="checkbox"/>	Processed	<input type="checkbox"/>	Raw and Processed
--------------------------	-----	--------------------------	-----------	--------------------------	-------------------

When images are printed, on what device is the print command originated? (Pick all that apply)

<input type="checkbox"/>	The system	<input type="checkbox"/>	A review workstation	<input type="checkbox"/>	A PACS system
--------------------------	------------	--------------------------	----------------------	--------------------------	---------------

How soon after the images are acquired is the first image quality check done?

<input type="checkbox"/>	Before the next image is shot	<input type="checkbox"/>	Before the patient leaves	<input type="checkbox"/>	After patient leaves
--------------------------	-------------------------------	--------------------------	---------------------------	--------------------------	----------------------

When it comes to image quality, would you prefer to;

- Consider all images good unless marked bad
- Consider all images bad unless marked good

6.2.4 The Physical Network

Physical infrastructures vary widely from institution to institution. GE HealthCare tried to pick the most popular networking connection to ease integration into your facility's network. In the system room, this facility;

<input type="checkbox"/>	Has 100baseT installed	<input type="checkbox"/>	Has 10baseT installed	<input type="checkbox"/>	Has a different network installed
<input type="checkbox"/>	Will have 100baseT installed	<input type="checkbox"/>	Will have 10baseT installed	<input type="checkbox"/>	We don't have a network installed

Do you segment your network using subnets?

<input type="checkbox"/>	Yes	<input type="checkbox"/>	No
--------------------------	-----	--------------------------	----

Our equipment's IP addresses are:

<input type="checkbox"/>	Static	<input type="checkbox"/>	Acquired via DHCP	<input type="checkbox"/>	A combination of both methods
--------------------------	--------	--------------------------	-------------------	--------------------------	-------------------------------

6.2.5 System Parameters

The system default uses the following IP Addresses internally:

- 192.168.1.1 eth0
- 192.168.2.1 eth1
- 192.168.3.1 br0 (eth2/3)
- 192.168.3.30 detector IP before detector boot
- 192.168.1.xx detector IP after boot in table
- 192.168.2.xx detector IP after boot in WS
- 192.168.3.xx detector IP after boot in Tether/wireless
- 192.168.4.30 AP IP

NOTICE

If the hospital network uses 192.168.x.x, there will be a conflict. If this conflict occurs, you must contact your GE HealthCare Service Representative to change the internal IP Addresses used by the system.

System

Host Name: _____

Network (IP) Address: ____ . ____ . ____ . ____

Subnet Mask: ____ . ____ . ____ . ____

Router IP: ____ . ____ . ____ . ____

Scheduled Station AE Title: _____

The Host Name is the network's name for the system. IP addresses uniquely identify a device on a network. IP addresses are constructed of 32 bits, usually displayed as four numbers separated by a period. Please indicate the Network (IP) Address that will be assigned to the system.

Subnets are a method of logically dividing a network into smaller blocks. This is usually done based upon locality, functionality or security requirements. If your facility will place the system on a subnet, please list the Subnet Mask and Router IP.

The Scheduled Station AE (Application Entity) Title is the name your HIS/RIS system will use to send worklist information to the system.

Table 6-1 Remote Host Data

Remote Hosts	Include a DICOM Compliance Statement for each device			
This remote Host is a:	<input type="checkbox"/> Review Work Station <input type="checkbox"/> Archival Device <input type="checkbox"/> PACS System <input type="checkbox"/> MPPS Server	<input type="checkbox"/> Review Work Station <input type="checkbox"/> Archival Device <input type="checkbox"/> PACS System <input type="checkbox"/> MPPS Server	<input type="checkbox"/> Review Work Station <input type="checkbox"/> Archival Device <input type="checkbox"/> PACS System <input type="checkbox"/> MPPS Server	Information on the System The system allows you to configure only 1 HIS/RIS server. The system allows you to configure only 1 MPPS server. The system allows configuration of multiple printers and multiple PACS/archive/review stations. The Host Name of all the nodes configured on the system should be unique within the system.
Manufacturer/Model:				
Software/Firmware version:				

Table 6-1 Remote Host Data (Table continued)

Remote Hosts	Include a DICOM Compliance Statement for each device		
Network (IP) Address: DICOM Compliance Level: Image Types Supported: Supports Multi-framing: Host Name:	----- _ <input type="checkbox"/> 1.0 <input type="checkbox"/> 2.0 <input type="checkbox"/> 3.0 <input type="checkbox"/> Not DICOM Compliant <input type="checkbox"/> DX <input type="checkbox"/> CR <input type="checkbox"/> Yes <input type="checkbox"/> No	----- _ <input type="checkbox"/> 1.0 <input type="checkbox"/> 2.0 <input type="checkbox"/> 3.0 <input type="checkbox"/> Not DICOM Compliant <input type="checkbox"/> DX <input type="checkbox"/> CR <input type="checkbox"/> Yes <input type="checkbox"/> No	----- _ <input type="checkbox"/> 1.0 <input type="checkbox"/> 2.0 <input type="checkbox"/> 3.0 <input type="checkbox"/> Not DICOM Compliant <input type="checkbox"/> DX <input type="checkbox"/> CR <input type="checkbox"/> Yes <input type="checkbox"/> No
Do you plan to use this device as a: Remote Host Server? AE Title:	<input type="checkbox"/> Yes <input type="checkbox"/> No If "yes" provide:	<input type="checkbox"/> Yes <input type="checkbox"/> No If "yes" provide:	<input type="checkbox"/> Yes <input type="checkbox"/> No If "yes" provide:
Port Number:			
Query/Retrieve? Query/Retrieve AE Title:	<input type="checkbox"/> Yes <input type="checkbox"/> No If "yes" provide:	<input type="checkbox"/> Yes <input type="checkbox"/> No If "yes" provide:	<input type="checkbox"/> Yes <input type="checkbox"/> No If "yes" provide:
Port Number:			
Query/Retrieve by:	<input type="checkbox"/> Study <input type="checkbox"/> Patient	<input type="checkbox"/> Study <input type="checkbox"/> Patient	<input type="checkbox"/> Study <input type="checkbox"/> Patient
Storage Commitment? Storage Commitment AE Title:	<input type="checkbox"/> Yes <input type="checkbox"/> No If "yes" provide:	<input type="checkbox"/> Yes <input type="checkbox"/> No If "yes" provide:	<input type="checkbox"/> Yes <input type="checkbox"/> No If "yes" provide:
Port Number:			
Network (IP) Address:	-----	-----	-----
MPPS Server? AE Title:	<input type="checkbox"/> Yes <input type="checkbox"/> No If "yes" provide:	<input type="checkbox"/> Yes <input type="checkbox"/> No If "yes" provide:	<input type="checkbox"/> Yes <input type="checkbox"/> No If "yes" provide:
Port Number:			
Network (IP) Address:	-----	-----	-----

6.2.6 Devices & Services Audit

Use the following narrative to complete the form on the previous page.

REMOTE HOSTS: Remote hosts are DICOM devices to which the system can push an image. Remote hosts can be review workstations, archival devices, or PACS systems. Please indicate the type of remote host. Now indicate the manufacturer and model name or number.

Compatibility can vary with software versions, please indicate the version of device firmware/software the device will be running.

List the device's **IP address**.

The answers to the next several items can be found in the device's DCS (DICOM Conformance Statement).

Please indicate the highest level of **DICOM conformance** for this device. If the device is not DICOM compliant, please indicate so and move on to the next device.

If the device does have some level of DICOM conformance please return a copy of the DICOM Conformance Statement with this completed form.

DICOM supports a number of **image types**. Please indicate if this device supports the DX and/or the CR image types.

The **host name** is the name that will appear on the screen and users will use to indicate this device. Please list the host name.

The next four sections address the four services that remote host devices may offer. Each of the services will have its own AE (application entity) title and port number. The AE title is the name given to a service or application provided by a DICOM device. The port number is a logical designation within the device. These pieces of information are available in the device's DCS.

Being a **remote host server** allows the system to push images to other devices. If you want the device to accept this service, check yes and provide the AE title and port number.

Being a **query/retrieve** service class provider allows the system to query this device and retrieve images stored there. If you want this device to provide these services to the system check yes and fill in the requested items.

The **query/retrieve** by study or patient controls how much the user is able to retrieve at one time. For study, the user may retrieve studies, series, images. For patient, the user may retrieve all of the study attributes plus a patient's entire image collection.

A **storage commitment** provider confirms that images sent by the Discovery XR656 HD system to an archival system were received and stored. Note - This option is only available when the system is sending DX type images. If your device supports both DX image types and storage commitment check yes and provide the AE title, the port number and the network (IP) address.

The **MPPS server** receives the messages sent by the system. These messages consist of information such as when the exam started and closed, how many images were acquired, dose information, etc. This information is then updated on the Hospital Scheduling system. If the site has an MPPS server, provide the AE Title, IP address and port number.

Printers	Include a DICOM Compliance Statement for each printer	
Manufacturer/Model:		
Software/Firmware Version:	<input type="checkbox"/> Yes <input type="checkbox"/> No	<input type="checkbox"/> Yes <input type="checkbox"/> No
Prints via Spooler:	_____	_____
Network (IP) Address:	<input type="checkbox"/> 1.0	<input type="checkbox"/> 1.0
DICOM Compliance Level:	<input type="checkbox"/> 2.0	<input type="checkbox"/> 2.0
Host Name:	<input type="checkbox"/> 3.0	<input type="checkbox"/> 3.0
Printer AE Title:	<input type="checkbox"/> Not DICOM Compliant	<input type="checkbox"/> Not DICOM Compliant
Port Number:		

Printers: As with the remote hosts, please list the manufacturer and the model name/number. The software/firmware version should also be entered. Next, supply the IP address of the printer.

Indicate the DICOM compliance level of the printer. If it is not DICOM compatible, please indicate so.

DICOM compatibility does not guarantee all functions will work properly. **Include every unique printer's DICOM Compliance Statement.**

Supply the Host name for the printer.

Look in the DCS for the printer's AE title and port number.

RIS Systems	Include a DICOM Compliance Statement for each device	
Manufacturer/Model:		
Software/Firmware Version:	-----	-----
Network (IP) Address:	<input type="checkbox"/> 1.0 <input type="checkbox"/> 2.0 <input type="checkbox"/> 3.0	<input type="checkbox"/> 1.0 <input type="checkbox"/> 2.0 <input type="checkbox"/> 3.0
DICOM Compliance Level:	<input type="checkbox"/> Not DICOM Compliant	<input type="checkbox"/> Not DICOM Compliant
Host Name:		
HIS/RIS AE Title:	<input type="checkbox"/> DX <input type="checkbox"/> CR	<input type="checkbox"/> DX <input type="checkbox"/> CR
Port Number:		
Modality used for Scheduling:		

RIS Systems: As with the remote hosts please list the manufacturer and the model name/number. The software/firmware version should also be entered. Indicate the IP address the device is using as well as the DICOM compliance level. Please include the DCS for the RIS with this completed form.

Fill in the Host name. Look in the DCS for the AE title and port number. Please indicate if this device supports the DX and/or the CR image types. This information should also be in the device's DCS.

6.2.7 Data Flow Analysis

Now that we have outlined the way your facility works and the devices you work with, we would like to define how the images flow through your network.

The system is an acquisition-only device. Because of that fact you will need to move acquired images off the system and into your work/data flow. Please use the chart below to describe your data flow. As an example, if your facility reviewed images as the first step after acquisition, the review box would be checked in the first column of the Task row (shaded) and the review workstation would be checked in the first column of the Device row. You should use each of the functions once.

1st step after acquisition	2nd step after acquisition	3rd step after acquisition
<input type="checkbox"/> Archive	<input type="checkbox"/> Archive	<input type="checkbox"/> Archive
<input type="checkbox"/> Print	<input type="checkbox"/> Print	<input type="checkbox"/> Print
<input type="checkbox"/> Review	<input type="checkbox"/> Review	<input type="checkbox"/> Review
<input type="checkbox"/> Archive device	<input type="checkbox"/> Archive device	<input type="checkbox"/> Archive device
<input type="checkbox"/> PACS	<input type="checkbox"/> PACS	<input type="checkbox"/> PACS
<input type="checkbox"/> Printer	<input type="checkbox"/> Printer	<input type="checkbox"/> Printer
<input type="checkbox"/> Review Workstation	<input type="checkbox"/> Review Workstation	<input type="checkbox"/> Review Workstation
<input type="checkbox"/> Spooler =>Printer(s)	<input type="checkbox"/> Spooler =>Printer(s)	<input type="checkbox"/> Spooler =>Printer(s)
<input type="checkbox"/> Spooler =>Review Workstation(s)	<input type="checkbox"/> Spooler =>Review Workstation(s)	<input type="checkbox"/> Spooler =>Review Workstation(s)

Printing: It is important to us to understand the path your images follow before they are printed. We are now looking to answer the question of what road an image most typically travels on its way to be printed regardless if that is the first step in your process or not. Please try to find in the list below the path that best describes the path the image takes from acquisition to printing.

- XR System =>Printer
- XR System =>Spooler =>Printer(s)
- XR System =>Archive Device =>Printer
- XR System =>Archive Device =>Spooler =>Printer (s)

- XR System =>Archive Device =>Review Workstation =>Printer
- XR System =>Archive Device =>Review Workstation =>Spooler =>Printer
- XR System =>PACS =>Printer
- XR System =>PACS =>Spooler =>Printer
- XR System =>Review Workstation =>Printer
- XR System =>Review Workstation =>Spooler =>Printer
- XR System =>Other: _____ =>Printer(s)

Image Review: Now let's trace the path from acquisition to image review. Again, pick the item below that best describes how the image flows from the system to the radiologist.

- XR System =>Printer =>Printed Film =>Radiologist
- XR System =>Review Workstation =>Radiologist
- XR System =>Archive Device =>Review Workstation =>Radiologist
- XR System =>PACS =>Radiologist
- XR System =>PACS =>Review Workstation =>Radiologist
- XR System =>Other: _____ =>Radiologist

Archive: The final part of this triad is archiving images. Pick the item below that best describes the flow of images to be archived.

- XR System =>Archive Device
- XR System =>PACS
- XR System =>Printer =>Printed Film =>Filing System
- XR System =>Review Workstation =>Archive Device
- XR System =>Review Workstation =>PACS
- XR System =>Other: _____ =>Archive Device

6.2.8 What Will Happen Next?

Next, your completed audit sheet will be analyzed by your GE HealthCare representative and any issues identified.

6.3 Remote Connection Configuration

Contact Security Administrator for information on outbound traffic allowance and to start connectivity work flows. The Optima XR646 HD (G3B Software) can connect to GE HealthCare Back Office / Online Center, this allows for remote health monitoring, diagnostics, and can help facilitate troubleshooting customer problems. Site information is required for configuration, see below. A site may require the System ID and System IP Address to begin work flow. The following URLs will need to be accepted by the site for outbound traffic to GE HealthCare:

- <https://insite.gehealthcare.com:443>
- <https://as1-insite.gehealthcare.com:443>
- <https://as2-insite.gehealthcare.com:443>

For EU Sites:

- <https://insite-eu.gehealthcare.com:443>
- <https://as1-insite-eu.gehealthcare.com:443>
- <https://as2-insite-eu.gehealthcare.com:443>

The Optima XR646 HD (G3B Software) can connect to GE HealthCare Back Office / OLC. This allows for remote diagnostic and help to facilitate troubleshooting customer problems. Site information is required for configuration, see below.

Table 6-2 Remote Connection Configuration Information

Can the device communicate on port 443/SSL?	<input type="checkbox"/> Yes <input type="checkbox"/> No
Is a proxy needed for outbound traffic	<input type="checkbox"/> Yes (Proceed with the following) <input type="checkbox"/> No (stop)
Proxy IP Address (XXX.XXX.XXX.XXX):	
Proxy Port Number:	
Does proxy require authentication?	<input type="checkbox"/> Yes (Proceed with the following) <input type="checkbox"/> No (stop)
Proxy Username:	
Proxy Password:	



NOTE

The vpn tunnel can be used for sites that were previously configured for insite 1 vpn connections. Enter the IP port for the server in the proxy details in the SUIF (Configuration -> Remote Connectivity -> Proxy).

Proxy Server Address: 150.2.1.251

Proxy Server Port: 8002 Open a case with RSVP team to map the new system in the back office to RSVP:

[http:// supportcentral.ge.com/ProcessMaps/ form_new_request.asp?prod_id=24026&form_id=249959&node_id=463500&map_id=&reference_id=&reference_type=](http://supportcentral.ge.com/ProcessMaps/form_new_request.asp?prod_id=24026&form_id=249959&node_id=463500&map_id=&reference_id=&reference_type=)

7 Cable Information

7.1 Cable Introduction

The following information is provided as an aid to make the physical installation of system cables easy and efficient. In the tables that follow, the physical characteristics of each cable and its associated connectors is provided. Thus making it easier to plan cable paths and clearances in advance. Physical characteristics are given for each available cable length. Review cable lengths carefully and choose lengths appropriate for your installation prior to the equipment arriving, to avoid unnecessary installation delays.

Remember, it is up to you to make sure that all cables are routed and connected in accordance with all regulatory laws that may apply.

7.2 Cable Information

7.2.1 OTS

ITEM	PART NO.	DESCRIPTION	LENGTH	USABLE LENGTH	RATING VOLTAGE	CONNECTOR SIZE (MM) L*W*D	CONNECTION	SHIELDED
1	5146500-7-ROHS	FeiTian OTS CAN and CANopen Cable - ROHS compliant	20M (65.62FT)	19.5M (63.98FT)	350ACV 500VDC	35 X 20 X 45	Cabinet to OTS	Shield
2	5146500-9-ROHS	FeiTian Tube Stator, Fan and Pressure Switch Cable - ROHS compliant.	25M (82.02FT)	24.5M (80.38FT)	350ACV 500VDC	40 X 30 X 30	Cabinet to OTS	Shield
3	5146500-12-ROHS	FeiTian OTS Power Cable-ROHS Compliant	20M (65.62FT)	19.5M (63.98FT)	350ACV 500VDC	28 X 20 X 45	Cabinet to OTS	Non-Shield
4	5160469-1	Fei Tian HV cable-Anode	25M (82.02FT)	24.5M (80.38FT)	75KV	190 X 80 X 80	Cabinet to OTS	Shield
5	5160469-2	Fei Tian HV Cable-cathode	25M (82.02FT)	24.5M (80.38FT)	75KV	190 X 80 X 80	Cabinet to OTS	Shield
6	5146500-8	FeiTian OTS Ground Cable	20M (65.62FT)	19.5M (63.98FT)	350ACV 500VDC	φ10 X 35	Cabinet to OTS	Non-Shield
7	5146500-14-ROHS	FeiTian OTS Console VGA Cable	30M (98.43FT)	29.5M (96.78FT)	350ACV 500VDC	35 X 20 X 45	Magic PC to OTS	Shield
8	5146500-13-ROHS	FeiTian OTS Console Touchscreen Cable	26M (85.30FT)	25.5M (83.66FT)	350ACV 500VDC	35 X 20 X 60	Magic PC to OTS	Shield

7.2.2 System MIS Cable-OTS

ITEM	PART NO.	DESCRIPTION	LENGTH	USABLE LENGTH	RATING VOLTAGE	CONNECTOR SIZE (MM) L*W*D	CONNECTION	SHIELDED
1	5491864	Optima 3M bridge OTS cable hose Assembly	30M (98.43FT)	29.5M (96.78FT)	NA	NA	NA	NA
2	5491865	Optima 2M bridge OTS cable hose Assembly	30M (98.43FT)	29.5M (96.78FT)	NA	NA	NA	NA

7.2.3 Table Standard Length MIS Cable 5777374

ITEM	PART NO.	DESCRIPTION	LENGTH	USABLE LENGTH	RATING VOLTAGE	CONNECTOR SIZE (MM) L*W*D	CONNECTION	SHIELDED
1	5307318-4	Table Ion chamber MIS cable	16M (52.49FT)	15.5M (50.85FT)	350ACV 500VDC	45 x 20 x 45	Cabinet to Table	Shield
2	5777034	Table Detector Ethernet MIS cable	50M (164.04FT)	49.5M (162.40)	350ACV 500VDC	20 x 12 x 40	PC to Table	Shield
3	5336729-4	Table Power MIS cable	16M (52.49FT)	15.5M (50.85FT)	350ACV 500VDC	30 x 25 x 30	Cabinet to Table	Non-Shield
4	5336730-4	Table DPS MIS cable	16M (52.49FT)	15.5M (50.85FT)	350ACV 500VDC	30 x 21 x 87	Cabinet to Table	Non-Shield
5	5336731-4	Table Can MIS cable	16M (52.49FT)	15.5M (50.85FT)	350ACV 500VDC	35 x 20 x 45	Cabinet to Table	Shield
6	5336736-4	Table Ground MIS cable	16M (52.49FT)	15.5M (50.85FT)	300V	φ10 X 35	Cabinet to Table	Non-Shield
7	5336737-4	Table Emergency Stop MIS cable	16M (52.49FT)	15.5M (50.85FT)	350ACV 500VDC	35 x 20 x 45	Cabinet to Table	Shield
8	5776868	Table TOMO Trigger	16M (52.49FT)	15.5M (50.85FT)	300V	39 x 33 x 16	Cabinet to Table	Shield

7.2.4 Table Long Length MIS Cables 5777375

ITEM	PART NO.	DESCRIPTION	LENGTH	USABLE LENGTH	RATING VOLTAGE	CONNECTOR SIZE (MM) L*W*D	CONNECTION	SHIELDED
1	5307318-5	Table Ion chamber MIS cable	21M (68.90FT)	20.5M (67.26FT)	350ACV 500VDC	45 x 20 x 45	Cabinet to Table	Shield
2	5777034	Table Detector Ethernet MIS cable	50M (164.04FT)	49.5M (162.40FT)	350ACV 500VDC	20 x 12 x 40	PC to Table	Shield

ITEM	PART NO.	DESCRIPTION	LENGTH	USABLE LENGTH	RATING VOLTAGE	CONNECTOR SIZE (MM) L*W*D	CONNECTION	SHIELDED
3	5336729-5	Table Power MIS cable	21M (68.90FT)	20.5M (67.26FT)	350ACV 500VDC	30 x 25 x 30	Cabinet to Table	Non-Shield
4	5336730-5	Table DPS MIS cable	21M (68.90FT)	20.5M (67.26FT)	350ACV 500VDC	30 x 21 x 87	Cabinet to Table	Non-Shield
5	5336731-5	Table Can MIS cable	21M (68.90FT)	20.5M (67.26FT)	350ACV 500VDC	35 x 20 x 45	Cabinet to Table	Shield
6	5336736-5	Table Ground MIS cable	21M (68.90FT)	20.5M (67.26FT)	300V	φ10 X 35	Cabinet to Table	Non-Shield
7	5336737-5	Table Emergency Stop MIS cable	21M (68.90FT)	20.5M (67.26FT)	350ACV 500VDC	35 x 20 x 45	Cabinet to Table	Shield
8	5758574	Table TOMO Trigger	21M (68.90FT)	20.5M (67.26FT)	300V	39 x 33 x 16	Cabinet to Table	Shield

7.2.5 Standard WS Length Version 5777377

ITEM	PART NO.	DESCRIPTION	LENGTH	USABLE LENGTH	RATING VOLTAGE	CONNECTOR SIZE (MM) L*W*D	CONNECTION	SHIELDED
1	5336717-2	WS CAN Cable	15M (49.21FT)	14.5M (47.57FT)	350ACV 500VDC	35 x 20 x 45	Cabinet to WS	Shield
2	5336733-2	WS ION Chamber Cable	15M (49.21FT)	14.5M (47.57FT)	350ACV 500VDC	45 x 20 x 45	Cabinet to WS	Shield
3	5336732-2	WS DPS Power Cable	15M (49.21FT)	14.5M (47.57FT)	350ACV 500VDC	30 x 21 x 87	Cabinet to WS	Non-Shield
4	5336722-2	WS Power Cable	15M (49.21FT)	14.5M (47.57FT)	350ACV 500VDC	30 x 21 x 87	Cabinet to WS	Non-Shield
5	5336738-2	WS Ground Cable	15M (49.21FT)	14.5M (47.57FT)	300V	φ10 X 35	Cabinet to WS	Non-Shield
6	5777036	G3 WS Detector Ethernet MIS cable	30M (98.4FT)	29.5M (96.7FT)	350ACV 500VDC	20 x 12 x 40	PC to WS	Shield
7	5776872	WS TOMO Trigger	15M (49.21FT)	14.5M (47.57FT)	300V	39 x 33x 16	Cabinet to WS	Shield

7.2.6 Ext WS Length Version 5777376

ITEM	PART NO.	DESCRIPTION	LENGTH	USABLE LENGTH	RATING VOLTAGE	CONNECTOR SIZE (MM) L*W*D	CONNECTION	SHIELDED
1	5336717	WS CAN and CAN open Cable	20M (65.62FT)	19.5M (63.98FT)	350ACV 500VDC	35 x 20 x 45	Cabinet to WS	Shield

ITEM	PART NO.	DESCRIPTION	LENGTH	USABLE LENGTH	RATING VOLTAGE	CONNECTOR SIZE (MM) L*W*D	CONNECTION	SHIELDED
2	5336733	WS ION Chamber Cable	20M (65.62FT)	19.5M (63.98FT)	350ACV 500VDC	45 x 20 x 45	Cabinet to WS	Shield
3	5777036	PC Ethernet cable to Wall Stand	30M (98.4FT)	29.5M (96.7FT)	350ACV 500VDC	20 x 12 x 40	PC to WS	Shield
4	5336732	WS DPS Power Cable	20M (65.62FT)	19.5M (63.98FT)	350ACV 500VDC	30 x 21 x 87	Cabinet to WS	Non-Shield
5	5336722	WS Power Cable	20M (65.62FT)	19.5M (63.98FT)	350ACV 500VDC	30 x 21 x 87	Cabinet to WS	Non-Shield
6	5336738	WS Ground Cable	20M (65.62FT)	19.5M (63.98FT)	300V	φ10 X 35	Cabinet to WS	Non-Shield
7	5758575	WS TOMO Trigger	20M (65.62FT)	19.5M (63.98FT)	300V	39 x 33x 16	Cabinet to WS	Shield

7.2.7 TIB

ITEM	PART NO.	DESCRIPTION	LENGTH	USABLE LENGTH	RATING VOLTAGE	CONNECTOR SIZE (MM) L*W*D	CONNECTION	SHIELDED
1	5402662	TIB Power Cable	20M (65.62FT)	19.5M (63.98FT)	350ACV 500VDC	35 x 40 x 87	TIB Box To Cabinet	Non-Shield
2	5777037	TIB Ethernet Cable	25M (82.02FT)	24.5M (80.38FT)	350ACV 500VDC	20 x 12 x 40	TIB Box To Magic PC	Shield
3	5736526-4	FlashPad HD Tether with Plug Asm, 4m	4M (13.12FT)	3.5M (11.48FT)	350ACV 500VDC	100 x 28 x 110	TIB Box To Detector	Shield
4	5736526-7	FlashPad HD Tether with Plug Asm, 7m	7M (13.12FT)	6.5M (11.48FT)	350ACV 500VDC	100 x 28 x 110	TIB Box To Detector	Shield
5	5736526-10	FlashPad HD Tether with Plug Asm, 10m	10M (13.12FT)	9.5M (11.48FT)	350ACV 500VDC	100 x 28 x 110	TIB Box To Detector	Shield
6	5789055	G3A TIB grounding MIS cable	16M (52.49FT)	15.5M (50.85FT)	300V	φ10 X 35	TIB Box To Cabinet	Non-Shield

7.2.8 Wireless AP

ITEM	PART NO.	DESCRIPTION	LENGTH	USABLE LENGTH	RATING VOLTAGE	CONNECTOR SIZE (MM) L*W*D	CONNECTION	SHIELDED
1	5772927	Wireless AP Power MIS Cable	20M (65.62FT)	19.5M (63.98FT)	300V	φ35 X 50	Cabinet to AP power	Non-Shield

ITEM	PART NO.	DESCRIPTION	LENGTH	USABLE LENGTH	RATING VOLTAGE	CONNECTOR SIZE (MM) L*W*D	CONNECTION	SHIELDED
2	5772928	Wireless AP Ethernet MIS Cable	25M (82.02FT)	24.5M (80.38FT)	350ACV 500VDC	20 x 12 x 40	PC to AP	Shield
3	5851609	AP315 power cable	0.3M (0.98FT)	0.25M (0.82FT)	500VDC	20 x 12 x 40	AP power to AP	Non-Shield

7.2.9 Control Room MIS Cable (without Wall Box)

ITEM	PART NO.	DESCRIPTION	LENGTH	USABLE LENGTH	RATING VOLTAGE	CONNECTOR SIZE (MM) L*W*D	CONNECTION	SHIELDED
1	5835456	RCIM, PC to Cabinet	20M (65.62FT)	19.5M (63.98FT)	350ACV 500VDC	45 x 20 x 45	RCIM2 to Cabinet	Shield
2	5835455	PC, Monitor Power Cable	20M (65.61FT)	19.5M (63.98FT)	350ACV 500VDC	35 x 40 x 60	Monitor to Cabinet	Non-Shield
3	5336726	Substitute 5146500-24 for Rohs compliance, FeiTian Magic PC Ground Cable	20M (65.61FT)	19.5M (63.98FT)	300V	φ10 X 35	Magic PC to Cabinet	Non-Shield
4	5835454	Jedi CAN, PC to Cabinet	20M (65.61FT)	19.5M (63.98FT)	350ACV 500VDC	35 x 20 x 45	Magic PC to Cabinet	Shield
5	5835453	System CAN, PC to Cabinet	20M (65.61FT)	19.5M (63.98FT)	350ACV 500VDC	35 x 20 x 45	Magic PC to Cabinet	Shield

7.2.10 Control Room MIS Cable (with Wall Box, only applied for IB)

ITEM	PART NO.	DESCRIPTION	LENGTH	USABLE LENGTH	RATING VOLTAGE	CONNECTOR SIZE (MM) L*W*D	CONNECTION	SHIELDED
1	5341236	26 PIN HD D-SUB CABLE	3M (9.84FT)	2.8M (9.19FT)	350ACV 500VDC	45 x 20 x 45	RCIM2 to Wall Box	Shield
2	5341237-2	26 PIN HD D-SUB CABLE	20M (65.62FT)	19.5M (63.98FT)	350ACV 500VDC	45 x 20 x 45	Wall Box to Cabinet	Shield
3	5146500-17	FeiTian WBI CRE Power Cable	20M (65.62FT)	19.5M (63.98FT)	350ACV 500VDC	28 X 20 X 45	Cabinet to Wall Box	Non-Shield
4	5146500-18	FeiTian WBI Ground Cable	20M (65.62FT)	19.5M (63.98FT)	300V	φ10 X 35	Cabinet to Wall Box	Non-Shield
5	5336726	Magic PC Ground Cable	18M (59.06FT)	17.5M (57.41FT)	300V	φ10 X 35	Magic PC to Wall Box	Non-Shield

ITEM	PART NO.	DESCRIPTION	LENGTH	USABLE LENGTH	RATING VOLTAGE	CONNECTOR SIZE (MM) L*W*D	CONNECTION	SHIELDED
6	5336719	Substitute 5146500-15 for Rohs compliance, FeiTian II WBI Jedi CAN Cable	20M (65.62FT)	19.5M (63.98FT)	350ACV 500VDC	35x20x45	Cabinet to Wall Box	Shield
7	5336720	Substitute 5146500-16 for Rohs compliance, FeiTian II WBI CAN Cable	20M (65.62FT)	19.5M (63.98FT)	350ACV 500VDC	35x20x45	Cabinet to Wall Box	Shield
8	5336721	Magic PC Jedi CAN Cable	3M (9.84FT)	2.8M (9.19FT)	350ACV 500VDC	35 x 20 x 45	Magic PC to Wall Box	Shield
9	5336723	Magic PC System CAN open Cable	3M (9.84FT)	2.8M (9.19FT)	350ACV 500VDC	35 x 20 x 45	Magic PC to Wall Box	Shield

7.2.11 Computer

ITEM	PART NO.	DESCRIPTION	LENGTH	USABLE LENGTH	RATING VOLTAGE	CONNECTOR SIZE (MM) L*W*D	CONNECTION	SHIELDED
1	5146500-22	FeiTian Image Monitor Cable (Viewer Monitor)	3M (9.84FT)	2.8M (9.19FT)	350ACV 500VDC	35 x 42 x 60	Monitor to Cabinet	Non-Shield
2	5336724	Magic PC Power Cable	3M (9.84FT)	2.8M (9.19FT)	350ACV 500VDC	35 x 40 x 60	Magic PC to Cabinet	Non-Shield

7.3 System Master Interconnect Schematic (MIS Map)

Figure 7-1 Without Wall Box

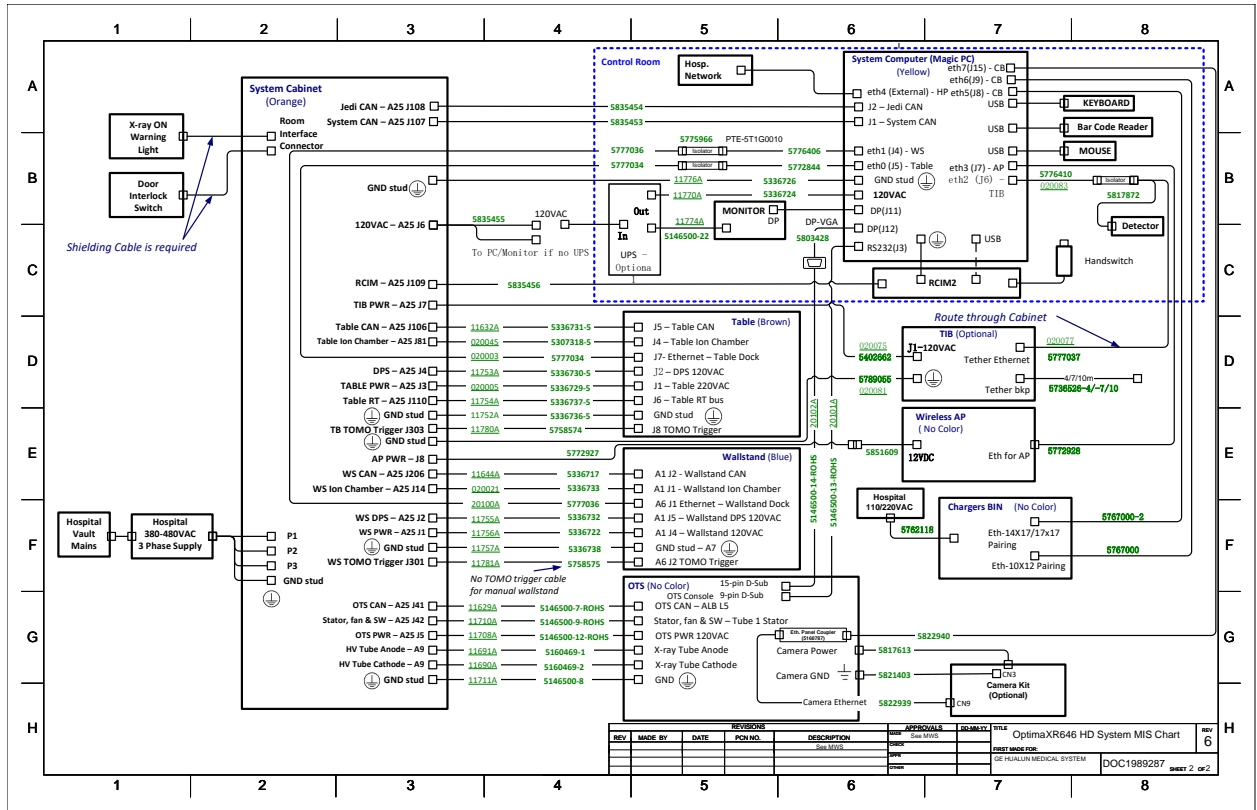
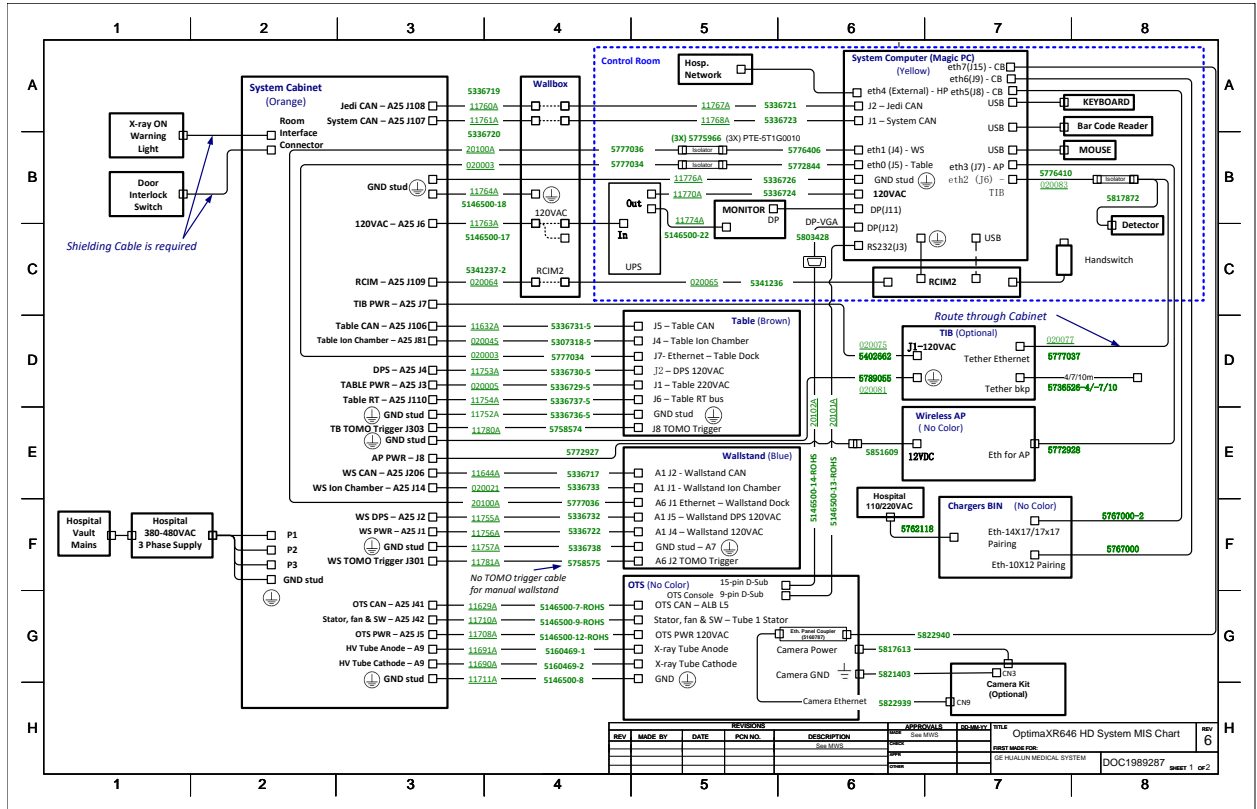
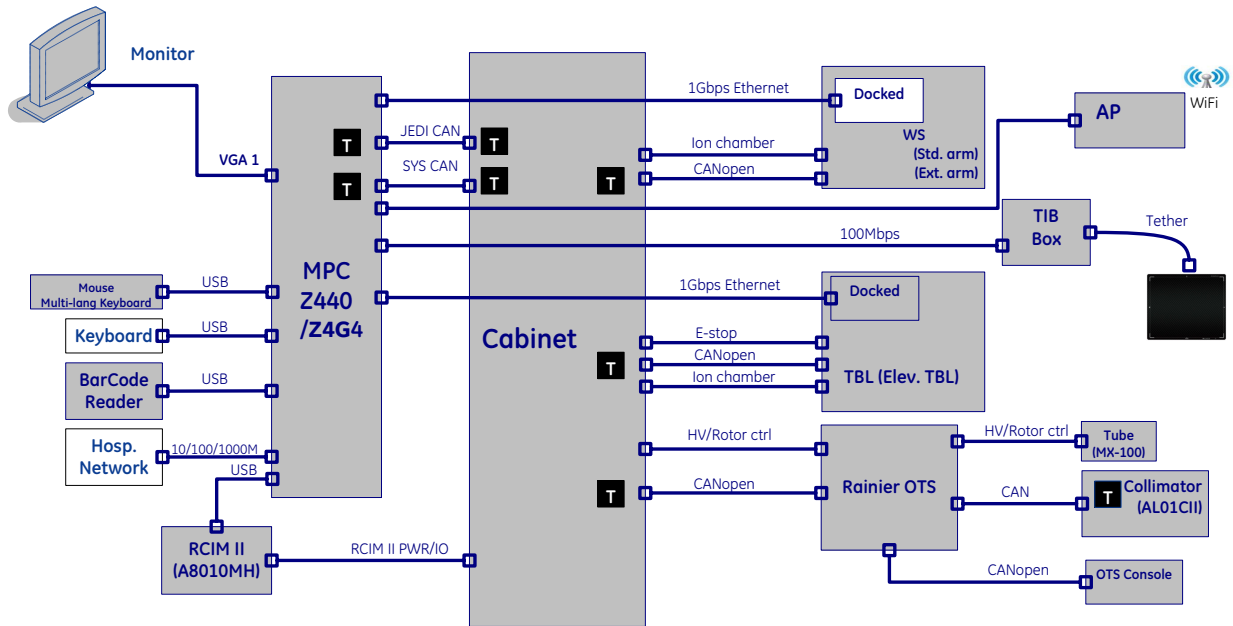

Figure 7-2 With Wall Box



7.4 System Architecture

XR646 HD Architecture - SIGNAL



XR646 HD Architecture POWER & GROUNDING

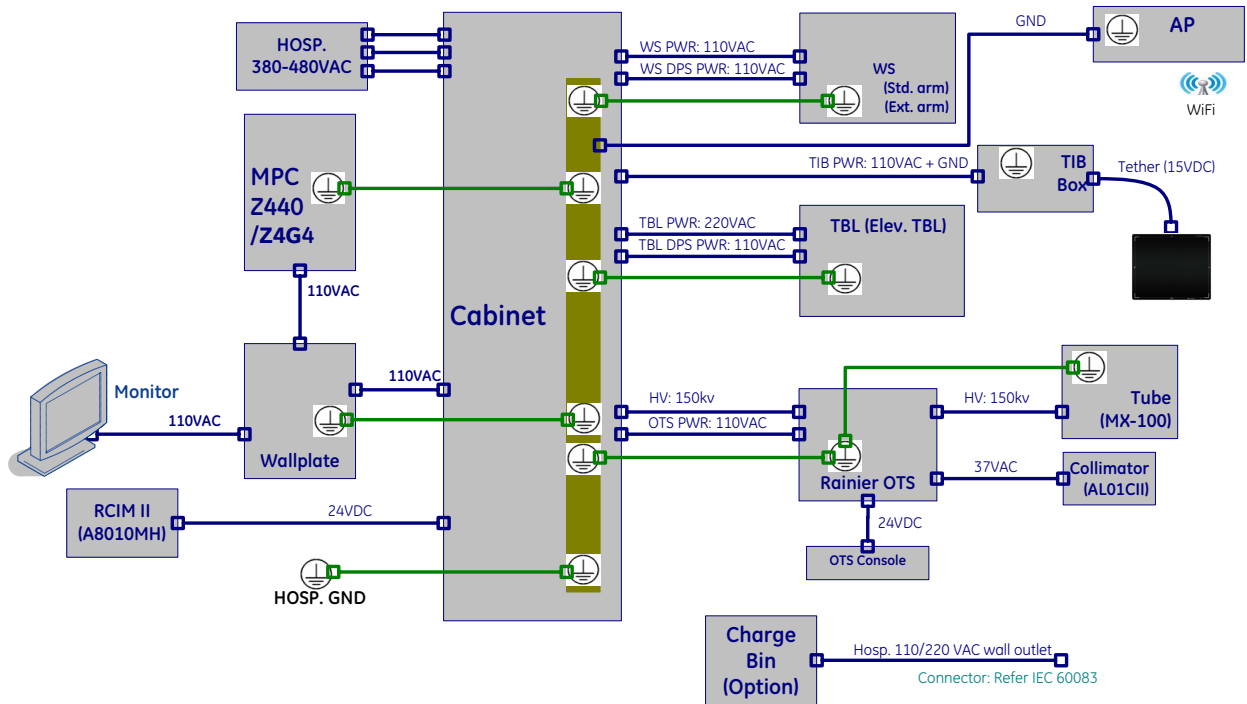



GE HealthCare

www.gehealthcare.com