



# Allia™ IGS 3, Allia™ IGS 5

## Pre-Installation Manual

5914487-8EN  
Revision 6  
US English

## Important...X-Ray Protection



### WARNING

X-ray equipment if not properly used may cause injury. Accordingly, the instructions herein contained should be thoroughly read and understood by everyone who will use the equipment before you attempt to place this equipment in operation. GE HealthCare will be glad to assist and cooperate in placing this equipment in use.

Although this apparatus incorporates a high degree of protection against x-radiation other than the useful beam, no practical design of equipment can provide complete protection. Nor can any practical design compel the operator to take adequate precautions to prevent the possibility of any persons carelessly exposing themselves or others to radiation.

It is important that anyone having anything to do with x-radiation be properly trained and fully acquainted with the recommendations of the National Council on Radiation Protection and Measurements as published in NCRP Reports available from NCRP Publications, 7910 Woodmont Avenue, Room 1016, Bethesda, Maryland 20814, and of the International Commission on Radiation Protection, and take adequate steps to protect against injury.

The equipment is sold with the understanding that GE HealthCare, its agents, and representatives have no responsibility for injury or damage which may result from improper use of the equipment.

Various protective materials and devices are available. It is urged that such materials or devices be used.

# Language Policy

## DOC0371395 - Global Language Procedure

PARALAJ-MËRIM (SQ-AL)	<p>Ky manual është i disponueshëm në disa gjuhë.</p> <ul style="list-style-type: none"> <li>Nëse një ofrues shërbimi klientësh kërkon një gjuhë të ndryshme nga ato që mundësohen në Portalin e dokumentacionit të klientit, është përgjegjësia e klientit që të ofrojë shërbime përkthimi.</li> <li>Mos u përpiqni të kryeni shërbime në pajisje, pa lexuar dhe kuptuar paraprakisht manualin e shërbimit.</li> <li>Mosrespektimi i këtij paralajmërimi mund të çojë në lëndim të ofruesit të shërbimit, operatorit ose pacientit si pasojë e goditjes elektrike, mekanike ose një rreziku tjetër.</li> </ul>
تحذير (AR-SA)	<p>هذا الدليل متوفر بعدة لغات</p> <ul style="list-style-type: none"> <li>إذا كان مقدم الخدمة التابع للعميل يطلب لغة غير تلك المتوفرة في بوابة توثيق العميل، فإنه يقع على عاتق العميل مسؤولية تقديم خدمات الترجمة</li> <li>لا تحاول صيانة الجهاز ما لم تتم استشارة دليل الخدمة هذا وفهمه</li> <li>قد يؤدي عدم مراعاة هذا التحذير إلى إصابة مقدم الخدمة أو المشغل أو المريض من جراء الصدمات الكهربائية أو المخاطر الميكانيكية أو غيرها من المخاطر</li> </ul>
ПРЕДУПРЕЖДЕНИЕ (BG)	<p>Това ръководство е налично на няколко езика.</p> <ul style="list-style-type: none"> <li>Ако доставчикът на услуги на даден клиент изисква език, който е различен от осигурените в портала с документация за клиенти, отговорност на клиента е да предостави преводачески услуги.</li> <li>Не се опитвайте да обслужвате оборудването, освен ако не сте се консултирали с това сервизно ръководство и сте го разбрали.</li> <li>Несъблюдаването на това предупреждение може да доведе до нараняване на предоставящия услугите, оператора или пациента вследствие на токов удар, механична или други опасности.</li> </ul>
警告 (ZH-CN)	<p>本手册有多种语言版本。</p> <ul style="list-style-type: none"> <li>如果客户的服务提供商要求使用 Customer Documentation Portal (客户文档门户) 未提供的其他语言, 则客户有责任提供相应的翻译服务。</li> <li>请勿尝试检修设备, 除非已明确参考并理解本检修手册。</li> <li>不遵循此警告可能会导致检修服务提供者、操作员或患者受到触电、机械或其他危害的损伤。</li> </ul>
警告 (ZH-HK)	<p>本手冊備有多個語言版本。</p> <ul style="list-style-type: none"> <li>若客戶的服務提供者所需語言版本不在 Customer Documentation Portal (客戶文件入口網站) 所列語言之中, 客戶需自行負責提供翻譯服務。</li> <li>除非已查閱並理解本檢修手冊, 否則, 請勿嘗試檢修設備。</li> <li>不遵循此警告可能會導致服務提供者、操作員或患者因為觸電、機械或其他危險而受傷。</li> </ul>
警告 (ZH-TW)	<p>本手冊備有多個語言版本。</p> <ul style="list-style-type: none"> <li>若客戶的服務提供者所需語言版本不在 Customer Documentation Portal (客戶文件入口網站) 所列語言之中, 客戶需自行負責提供翻譯服務。</li> <li>除非已查閱並理解本檢修手冊, 否則, 請勿嘗試檢修設備。</li> <li>不遵循此警告可能會導致服務提供者、操作員或患者因為觸電、機械或其他危險而受傷。</li> </ul>
UPOZOR-ENJE (HR)	<p>Ovaj je priručnik dostupan na nekoliko jezika.</p> <ul style="list-style-type: none"> <li>Ako serviser klijenta zahtijeva jezik koji nije jedan od jezika dostupnih na portalu s korisničkom dokumentacijom (Customer Documentation Portal), odgovornost je klijenta pružiti uslugu prevođenja.</li> <li>Nemojte pokušavati servisirati opremu ako niste proučili i razumjeli ovaj servisni priručnik.</li> <li>Nepoštovanje ovog upozorenja može izazvati ozljede servisera, rukovatelja ili pacijenta kao posljedicu strujnog udara, mehaničkih ili drugih opasnosti.</li> </ul>

VÝSTRAHA (CS)	<p>Tato příručka je k dispozici v několika jazycích.</p> <ul style="list-style-type: none"> <li>• Pokud zákazníkům poskytovatel služeb vyžaduje jiný jazyk než jazyky, které jsou k dispozici na portálu s uživatelskou dokumentací, je odpovědností zákazníka poskytnout překladatelské služby.</li> <li>• Nepokoušejte se provádět servis zařízení, aniž byste prostudovali tuto servisní příručku a porozuměli jí.</li> <li>• Nedodržení tohoto varování může vést ke zranění poskytovatele služeb, obsluhy nebo pacienta, způsobenému úrazem elektrickým proudem či mechanickým nebo jiným nebezpečím.</li> </ul>
ADVARSEL (DA)	<p>Denne vejledning fås på flere sprog.</p> <ul style="list-style-type: none"> <li>• Hvis en kundes tjenesteudbyder kræver et andet sprog end dem, der er til rådighed i Kundedokumentationsportalen, er det kundens ansvar at levere oversættelsestjenester.</li> <li>• Undgå at forsøge at udføre service på udstyret, medmindre du har læst og forstået denne servicevejledning.</li> <li>• Hvis du undlader at overholde denne advarsel, kan det føre til skader på servicemedarbejderen, operatøren eller patienten på grund af elektrisk stød, mekaniske eller andre farer.</li> </ul>
WAAR-SCHUWING (NL)	<p>Deze handleiding is in verschillende talen beschikbaar.</p> <ul style="list-style-type: none"> <li>• Als de serviceprovider van een klant een andere taal vereist dan de talen die beschikbaar worden gesteld in het Customer Documentation Portal (Klantdocumentatieportaal), is het de verantwoordelijkheid van de klant om vertaalservices te leveren.</li> <li>• Probeer geen service op de apparatuur uit te voeren zonder de servicehandleiding te hebben gelezen en begrepen.</li> <li>• Het negeren van deze waarschuwing kan leiden tot letsel bij de serviceprovider, de operator of de patiënt door elektrische schokken, mechanische of andere gevaren.</li> </ul>
WARNING (EN)	<p>This manual is available in several languages.</p> <ul style="list-style-type: none"> <li>• If a customer's service provider requires a language other than those provided in the Customer Documentation Portal, it is the customer's responsibility to provide translation services.</li> <li>• Do not attempt to service the equipment unless this service manual has been consulted and is understood.</li> <li>• Failure to heed this warning may result in injury to the service provider, operator or patient from electric shock, mechanical or other hazards.</li> </ul>
HOIATUS (ET)	<p>Käesolev juhend on saadaval mitmes keeles.</p> <ul style="list-style-type: none"> <li>• Kui kliendi teenusepakkuja vajab juhendit mõnes muus keeles, mida pole kliendidokumentatsiooni portaalis, on kliendi kohustuseks tõlketeenuste osutamine.</li> <li>• Ärge hakake seda seadet hooldama enne, kui olete käesolevat hooldusjuhendit lugenud ja selle sisu mõistnud.</li> <li>• Selle hoiatuse eiramine võib põhjustada hooldusteenuse pakkuja, operaatorile või patsiendile elektrilöögist, mehhaanilistest või muudest ohtudest tulenevaid vigastusi.</li> </ul>
VAROITUS (FI)	<p>Tämä opas on saatavilla useilla kielillä.</p> <ul style="list-style-type: none"> <li>• Jos asiakkaan palveluntarjoaja edellyttää muita kuin asiakkaan asiakirjaportaalissa saatavilla olevia kieliä, käännöspalveluiden tarjoaminen on asiakkaan vastuulla.</li> <li>• Lue huolto-opas huolellisesti ennen laitteen huoltotoimenpiteiden suorittamista.</li> <li>• Tämän varoituksen huomiotta jättäminen voi johtaa huollon suorittajan, laitteen käyttäjän tai potilaan loukkaantumiseen sähköiskun, mekaanisen vaaran tai muun vaaran vuoksi.</li> </ul>
ATTENTION (FR)	<p>Ce manuel est disponible en plusieurs langues.</p> <ul style="list-style-type: none"> <li>• Si le prestataire de services d'un client nécessite que le manuel soit rédigé dans une autre langue que celles fournies sur le Portail de Documentation Client, il incombe au client de le faire traduire.</li> <li>• Ne pas essayer d'assurer la maintenance de l'équipement sans avoir au préalable consulté et compris les informations contenues dans ce manuel.</li> <li>• Le non-respect de cet avertissement peut entraîner chez le technicien, l'opérateur ou le patient des blessures dues à des dangers électriques, mécaniques ou autres.</li> </ul>

WARNUNG (DE)	<p>Dieses Handbuch ist in mehreren Sprachen erhältlich.</p> <ul style="list-style-type: none"> <li>• Wenn ein Dienstleister des Kunden dieses in einer anderen Sprache als der im Kundendokumentationsportal verfügbaren benötigt, liegt es in der Verantwortung des Kunden, Übersetzungsdienstleistungen zu erbringen.</li> <li>• Wartungsarbeiten am Gerät dürfen nur durchgeführt werden, nachdem dieses Wartungshandbuch gelesen und verstanden wurde.</li> <li>• Andernfalls besteht Verletzungsgefahr für den Dienstleister, Bediener oder Patienten durch Stromschlag, mechanische Gefahren oder andere Gefahren.</li> </ul>
ΠΡΟΕΙΔΟΠΟΙ ΗΣΗ (EL)	<p>Αυτό το εγχειρίδιο διατίθεται σε διάφορες γλώσσες.</p> <ul style="list-style-type: none"> <li>• Εάν ο πάροχος υπηρεσιών συντήρησης ενός πελάτη χρειάζεται διαφορετική γλώσσα από αυτές που διατίθενται στο Customer Documentation Portal (Πύλη τεκμηριώσεων πελάτη), ο πελάτης είναι υπεύθυνος για την παροχή υπηρεσιών μετάφρασης.</li> <li>• Μην επιχειρήσετε να εκτελέσετε συντήρηση του εξοπλισμού, εάν δεν έχετε διαβάσει και κατανοήσει το παρόν εγχειρίδιο συντήρησης.</li> <li>• Εάν δεν τηρήσετε αυτήν την προειδοποίηση, μπορεί να προκληθεί τραυματισμός του παρόχου υπηρεσιών συντήρησης, του χειριστή ή του ασθενούς λόγω ηλεκτροπληξίας, μηχανικής βλάβης ή άλλου κινδύνου.</li> </ul>
אזהרה (HE)	<p>מדריך זה זמין במספר שפות</p> <ul style="list-style-type: none"> <li>• אם ספק שירות של לקוח זקוק לשפה שאינה מופקת ב Customer Documentation Portal (פורטל באחריות הלקוח לספק את שירותי התרגום, תיעוד ללקוחות)</li> <li>• אסור לנסות להעניק שירות לציוד לפני עיון במדריך שירות זה והבנת התוכן שלו</li> <li>• פעולה שלא בהתאם לאזהרה זו עלולה לגרום לפציעה של ספק השירות, המפעיל או המטופל כתוצאה מהתחשמלות, סיכונים מכניים או סיכונים אחרים</li> </ul>
FIGYELMEZ- TETÉS (HU)	<p>Ez a kézikönyv több nyelven is rendelkezésre áll.</p> <ul style="list-style-type: none"> <li>• Ha az ügyfél szervizszolgáltatója azoktól eltérő nyelvű kézikönyvet szeretne, mint amelyeket az Ügyféldokumentációs portálon biztosítunk, akkor az ügyfél feladata, hogy gondoskodjon a megfelelő fordításról.</li> <li>• Ne próbálkozzon a berendezés szervizelésével anélkül, hogy a jelen szervizkézikönyvet elolvasta és megértette volna.</li> <li>• Ennek a figyelmeztetésnek a figyelmen kívül hagyása áramütés, mechanikai vagy egyéb veszélyek következtében a szervizszolgáltató, a kezelő vagy a páciens sérülését okozhatja.</li> </ul>
AÐVÖRUN (IS)	<p>Þessi handbók er fánleg á mörgum tungumálum.</p> <ul style="list-style-type: none"> <li>• Ef þjónustuaðili viðskiptavinar þarfnast annars tungumáls en þessara tungumála er það á ábyrgð viðskiptavinarins að veita þýðingarþjónustu.</li> <li>• Ekki reyna að þjónusta búnaðinn fyrr en búið er að lesa og skilja þessa þjónustuhandbók.</li> <li>• Sé ekki farið eftir þessari viðvörðun getur það valdið meiðslum á þjónustuaðila, notanda eða sjúklingi af völdum raflosts, vélrænna áverka eða annarar hættu.</li> </ul>
PERINGATAN (IN)	<p>Manual ini tersedia dalam beberapa bahasa.</p> <ul style="list-style-type: none"> <li>• Jika penyedia layanan pelanggan membutuhkan bahasa selain dari yang disediakan dalam Portal Dokumentasi Pelanggan, merupakan tanggung jawab pelanggan untuk menyediakan layanan penerjemahan.</li> <li>• Jangan berupaya untuk melakukan servis pada peralatan sebelum menyimak manual servis dan memahami isinya.</li> <li>• Jika peringatan ini tidak ditaati, ini dapat menyebabkan cedera penyedia layanan, operator, atau pasien, akibat sengatan listrik, bahaya mekanis, atau bahaya lainnya.</li> </ul>
AVVERTENZA (IT)	<p>Il presente manuale è disponibile in varie lingue.</p> <ul style="list-style-type: none"> <li>• Qualora un fornitore di servizi del cliente richieda una lingua diversa da quelle fornite nel Portale con la documentazione per il cliente, sarà responsabilità del cliente fornire il servizio di traduzione corrispondente.</li> <li>• Non tentare di riparare l'apparecchiatura se non si è prima consultato e compreso il presente manuale di servizio.</li> <li>• Il mancato rispetto di questa avvertenza può provocare lesioni per il fornitore dei servizi, per l'operatore o per il paziente, a causa di scosse elettriche, meccaniche o altri pericoli.</li> </ul>

警告 (JA)	<p>本マニュアルは多言語で提供されています。</p> <ul style="list-style-type: none"> <li>お客様のサービスプロバイダが、お客様ドキュメントポータルページで使用されていない言語を必要とする場合は、お客様の責任で翻訳サービスを提供してください。</li> <li>機器の保守を行う場合は、必ず本サービスマニュアルを読み理解した上で行ってください。</li> <li>この警告に従わない場合は、サービスプロバイダー、オペレータ、または患者が、感電、機械的異常、またはその他の有害要因によって負傷する恐れがあります。</li> </ul>
경고 (KO)	<p>이 설명서는 여러 언어로 제공됩니다.</p> <ul style="list-style-type: none"> <li>고객의 서비스 제공자가 고객 문서 포털에 제공된 언어가 아닌 다른 언어를 요구하는 경우 번역 서비스를 제공하는 것은 고객의 책임입니다.</li> <li>이 서비스 설명서를 참고했고 이해하지 않는 한은 해당 장비를 수리하려고 시도하지 마십시오.</li> <li>이 경고를 지키지 않으면 감전, 기계상의 위험 또는 다른 위험으로부터 서비스 제공자, 사용자 또는 환자가 다칠 수 있습니다.</li> </ul>
BRĪDINĀ- JUMS (LV)	<p>Šī rokasgrāmata ir pieejama vairākās valodās.</p> <ul style="list-style-type: none"> <li>Ja klientu apkalpošanas speciālistam ir nepieciešama cita valoda, kas nav piedāvāta klientu dokumentācijas portālā, klienta pienākums ir nodrošināt tulkošanas pakalpojumus.</li> <li>Nemēģiniet veikt aprikojuma apkopi, kamēr nav izlasīta un izprasta apkopes rokasgrāmata.</li> <li>Ja šis brīdinājums netiek ņemts vērā, pakalpojumu sniedzējs, operators vai pacients var tikt savainots elektriskās strāvas trieciena, mehāniskas vai citas bīstamības rezultātā.</li> </ul>
ĮSPĖJIMAS (LT)	<p>Šis vadovas yra išverstas į keletą kalbų.</p> <ul style="list-style-type: none"> <li>Jei kliento paslaugų teikėjui reikalingas vertimas į kitą kalbą, kurios nėra kliento dokumentacijos portale, už vertimo paslaugų suteikimą atsako klientas.</li> <li>Neatlikite įrangos techninės priežiūros, kol neperžiūrėjote ir neišsiaiškinote šio techninės priežiūros vadovo.</li> <li>Nepaisant šio įspėjimo dėl elektros smūgio, mechaninio arba kitokio pavojaus gali būti sužalotas paslaugų teikėjas, operatorius arba pacientas.</li> </ul>
TWISSIJA (MT)	<p>Dan il-manwal huwa disponibbli f'diversi lingwi.</p> <ul style="list-style-type: none"> <li>Jekk fornitur tas-servizz ta' klient ikun jeħtieġ lingwa għajr dawk ipprovduti fil-Portal tad-Dokumentazzjoni tal-Klijent, hija r-responsabbiltà tal-klijent li jipprovidi servizzi ta' traduzzjoni.</li> <li>Tippruvax tagħmel service fuq it-tagħmir sakemm ma jkunx gie kkonsultat u mifhum dan il-manwal għas-service.</li> <li>Jekk wieħed jonqos milli josserva din it-twissija, dan jista' jwassal f'korriment lill-fornitur tas-servizz, lill-operatur jew lill-pazjent minn xokk elettriku, mekkaniku, jew perikli oħra.</li> </ul>
ADVARSEL (NO)	<p>Denne håndboken er tilgjengelig på flere språk.</p> <ul style="list-style-type: none"> <li>Hvis en kundes tjenesteleverandør krever et annet språk enn de som finnes i dokumentasjonsportalen for kunder, er det kundens ansvar å levere en oversettelsestjeneste.</li> <li>Ikke prøv å utfør service på utstyret med mindre man har konsultert og forstått servicehåndboken.</li> <li>Om denne advarselen ikke følges kan det føre til skade på tjenesteleverandør, operatør eller pasient fra elektrisk støt, mekanisk eller annen fare.</li> </ul>
OSTRZEŻE- NIE (PL)	<p>Niniejszy podręcznik jest dostępny w kilku językach.</p> <ul style="list-style-type: none"> <li>Jeżeli serwisant klienta wymaga języka, który nie został udostępniony w portalu dokumentacji klienta, obowiązkiem klienta jest zapewnienie usług tłumaczeniowych.</li> <li>Nie podejmować prób serwisowania urządzenia bez uprzedniego zapoznania się z niniejszym podręcznikiem serwisowym i zrozumienia jego treści.</li> <li>Nieprzestrzeganie tego ostrzeżenia może spowodować obrażenia u serwisanta, operatora lub pacjenta, spowodowane porażeniem prądem, zagrożeniami mechanicznymi lub innymi.</li> </ul>

<p>ATENÇÃO (PT-BR)</p>	<p>Este manual está disponível em vários idiomas.</p> <ul style="list-style-type: none"> <li>• Se o prestador de serviços de um cliente necessitar de um idioma diferente dos fornecidos no Portal da Documentação do Cliente, o fornecimento dos serviços de tradução é de responsabilidade do cliente.</li> <li>• Não tente realizar manutenção do equipamento a menos que o manual de serviço tenha sido consultado e seja entendido.</li> <li>• O não cumprimento deste aviso resultará em lesões ao provedor de serviço, operador ou paciente de choque elétrico, mecânico ou outros riscos.</li> </ul>
<p>ATENÇÃO (PT-PT)</p>	<p>Este manual está disponível em vários idiomas.</p> <ul style="list-style-type: none"> <li>• Se o fornecedor de serviços de um cliente necessitar de um idioma diferente dos fornecidos no Portal de Documentação do Cliente, é da responsabilidade do cliente assegurar os serviços de tradução.</li> <li>• Não experimente reparar o equipamento sem primeiro consultar, e compreender, o presente manual de assistência.</li> <li>• O incumprimento deste aviso pode resultar em ferimentos para o técnico de reparação, o operador ou o paciente decorrentes de perigos de eletrocussão, mecânicos ou outros.</li> </ul>
<p>ATENȚIE (RO)</p>	<p>Acest manual este disponibil în mai multe limbi.</p> <ul style="list-style-type: none"> <li>• Dacă furnizorul de servicii al unui client necesită o limbă diferită de cele furnizate în Customer Documentation Portal (Portalul cu documentație pentru clienți), este responsabilitatea clientului să furnizeze servicii de traducere.</li> <li>• Nu încercați să efectuați întreținerea echipamentului decât dacă ați consultat și ați înțeles acest manual de service.</li> <li>• Nerespectarea acestei avertizări poate duce la rănirea furnizorului de servicii, a operatorului sau a pacientului din cauza șocurilor electrice, mecanice sau a altor pericole.</li> </ul>
<p>ПРЕДУПРЕЖ ДЕНИЕ (RU)</p>	<p>Это руководство доступно на нескольких языках.</p> <ul style="list-style-type: none"> <li>• Если поставщику услуг заказчика требуется языковая версия, отличная от предложенных на портале документации для заказчиков, перевод руководства на необходимый язык осуществляется стороной заказчика.</li> <li>• Не начинайте эксплуатацию оборудования без предварительного надлежащего ознакомления с этим руководством.</li> <li>• Если вы проигнорируете это предупреждение, поставщик услуг, оператор или пациент могут получить механические травмы, травмы вследствие поражения электрическим током или другие увечья.</li> </ul>
<p>UPOZOR- ENJE (SR)</p>	<p>Ovaj priručnik je dostupan na nekoliko jezika.</p> <ul style="list-style-type: none"> <li>• Ako korisnikov serviser zahteva neki drugi jezik osim onih koji su dostupni na portalu sa korisničkom dokumentacijom (Customer Documentation Portal), klijent mora da obezbedi prevod.</li> <li>• Nemojte pokušavati da servisirate opremu ako niste proučili i razumeli ovaj priručnik za servisiranje.</li> <li>• Nepoštovanje ovog upozorenja može da izazove povrede servisera, operatera ili pacijenta kao posledicu strujnog udara, mehaničkih ili drugih opasnosti.</li> </ul>
<p>UPOZORNE- NIE (SK)</p>	<p>Táto príručka je k dispozícii v niekoľkých jazykoch.</p> <ul style="list-style-type: none"> <li>• Ak poskytovateľ služieb daného zákazníka požaduje jazyk odlišný od jazykov dostupných na portáli s dokumentáciou pre zákazníkov, za prekladateľské služby zodpovedá zákazník.</li> <li>• Nepokúšajte sa vykonávať servis na zariadení, pokiaľ ste si neprečítali a nepochopili pokyny v servisnej príručke.</li> <li>• Nedodržanie tohto varovania môže byť príčinou úrazu poskytovateľa servisu, obsluhy alebo pacienta v dôsledku zásahu elektrickým prúdom alebo v dôsledku mechanických alebo iných nebezpečenstiev.</li> </ul>

OPOZORILO (SL)	<p>Ta priročnik je na voljo v več jezikih.</p> <ul style="list-style-type: none"> <li>• Če ponudnik storitev stranke potrebuje priročnik v jeziku, ki ni na voljo na portalu z dokumentacijo stranke, mora stranka zagotoviti prevod.</li> <li>• Opreme ne poskušajte servisirati, če niste prebrali in razumeli tega servisnega priročnika.</li> <li>• V primeru neupoštevanja tega opozorila lahko pride do telesnih poškodb ponudnika storitev, upravljavca ali pacienta zaradi električnega udara, mehanskih ali drugih nevarnosti.</li> </ul>
ADVERTENCIA (ES)	<p>Este manual se encuentra disponible en varios idiomas.</p> <ul style="list-style-type: none"> <li>• Si el proveedor de servicios de un cliente requiere un idioma distinto de los proporcionados en el Customer Documentation Portal (Portal de documentación para clientes), es responsabilidad del cliente proporcionar los servicios de traducción.</li> <li>• No intente realizar el mantenimiento del sistema a menos que haya consultado y comprendido este manual de servicio.</li> <li>• El incumplimiento de esta advertencia puede causar lesiones al suministrador de servicios, el operador o el paciente debido a descarga eléctrica, mecánica u otros riesgos.</li> </ul>
VARNING (SV)	<p>Denna manual är tillgänglig på flera språk.</p> <ul style="list-style-type: none"> <li>• Om en kunds tjänsteleverantör behöver ett annat språk än de som tillgängliggjorts på portalen för kunddokumentation är det kundens ansvar att erbjuda översättningstjänster.</li> <li>• Försök inte att reparera utrustningen utan att först rådfråga och förstå denna servicehandbok.</li> <li>• Om denna varning inte beaktas kan det leda till skada för tjänsteleverantör, operatör eller patient genom elektrisk stöt, mekaniska eller andra faror.</li> </ul>
DİKKAT (TR)	<p>Bu kılavuz birden fazla dile sunulmaktadır.</p> <ul style="list-style-type: none"> <li>• Bir müşterinin servis sağlayıcısı Müşteri Belgeleri Portalı'nda sağlananlardan farklı bir dil talep ederse çeviri hizmeti sağlamak müşterinin sorumluluğundadır.</li> <li>• Bu servis kılavuzuna başvurmadan ve içeriğini anlamadan ekipman üzerinde servis işlemi yapmayı denemeyin.</li> <li>• Bu uyarıya uyulmaması; elektrik çarpması, mekanik tehlikeler veya başka tehlikelerden ötürü servis sağlayıcı, operatör veya hastanın yaralanmasıyla sonuçlanabilir.</li> </ul>
ПОПЕРЕДЖЕННЯ (UK)	<p>Цей посібник доступний кількома мовами.</p> <ul style="list-style-type: none"> <li>• Якщо постачальник послуг замовника використовує мову, яку не вказано на порталі з документацією для замовників, послуги з перекладу має забезпечити замовник.</li> <li>• Не починайте роботу з обладнанням без попереднього належного ознайомлення з посібником із використання.</li> <li>• Якщо ви проігноруйте це попередження, постачальник послуг, оператор або пацієнт можуть зазнати механічних травм, ураження електричним струмом або інших тілесних ушкоджень.</li> </ul>
CẢNH BÁO (VI)	<p>Tài liệu hướng dẫn này có sẵn ở một số ngôn ngữ.</p> <ul style="list-style-type: none"> <li>• Nếu nhà cung cấp dịch vụ của khách hàng yêu cầu ngôn ngữ khác với ngôn ngữ được cung cấp trong Cổng Thông Tin Tài Liệu Khách Hàng, khách hàng có trách nhiệm cung cấp dịch vụ dịch thuật.</li> <li>• Không cố bảo dưỡng thiết bị trừ khi đã tham khảo và hiểu rõ hướng dẫn sử dụng này.</li> <li>• Việc không chú ý đến cảnh báo này có thể dẫn đến thương tích cho nhà cung cấp dịch vụ, người vận hành hoặc bệnh nhân do điện giật, nguy hiểm cơ học hoặc các mối nguy hiểm khác.</li> </ul>

## Revision History

Part/Rev	Date	Reason for Change
5914487-8EN Rev 1	2023-07	First Release of direction 5914487-8EN
5914487-8EN Rev 2	2023-08	Second Release of direction 5914487-8EN
5914487-8EN Rev 3	2023-12	Introduction of Third Party on IGS Touch Panel option
5914487-8EN Rev 4	2024-12	Update of Pre-Installation Checklist, update of requirements for LDM protective screen, V-Point and Clinical Access
5914487-8EN Rev 5	2025-04	Introduction of IEC60601-1-2 Edition 4.1 and detector shipped on gantry, removal of 19" LCD monitors in Exam Room and various improvements (anchorage for Floor baseplate, table name ...)
5914487-8EN Rev 6	2025-10	Introduction of X-PDU, UPS 11 kVA and UPS 8 kVA Gen2.

# Contents

<b>1</b>	<b>General Requirements.....</b>	<b>13</b>
1.1	Objectives & Overview .....	13
1.1.1	Object and Scope of this manual .....	13
1.1.2	Pre-Installation Process.....	13
1.2	Customer Responsibilities .....	14
1.2.1	Responsibilities of the Purchaser/Customer .....	14
1.2.2	Equipment Classifications .....	15
1.2.3	Pre-Installation Checklist.....	16
1.3	Delivery Requirements.....	17
1.3.1	Shipping Information.....	17
1.3.1.1	Product Shipping Information .....	17
1.3.1.2	Detail of Shipping Information.....	19
1.3.2	Tools and Test Equipment .....	28
1.3.3	Door Size Requirements .....	30
1.3.4	Route Survey .....	31
1.4	Product Storage and Handling Requirements .....	32
1.4.1	Post-delivery warm up period .....	32
1.4.2	System Storage.....	32
1.4.3	Handling instructions .....	33
<b>2</b>	<b>Equipment Requirements .....</b>	<b>35</b>
2.1	System Components .....	35
2.1.1	Presentation of the 3 Rooms .....	35
2.1.2	Description of the System.....	36
2.1.2.1	Core System .....	36
2.1.2.2	Options.....	41
2.1.2.3	Components location and characteristics.....	48
2.1.3	Dimension Drawings .....	55
2.2	Room Layouts.....	95
2.2.1	Room Dimension Requirements .....	95
2.2.2	Room Layout Drawings.....	96
2.2.2.1	Exam Room Layout.....	96
2.2.2.2	Control Room Layout.....	102
2.2.2.3	Technical Room Layout .....	103
2.2.2.4	ECG Device Room Configurations .....	109
2.2.3	Room Layout Considerations .....	110
2.2.3.1	Clinical Access .....	110
2.2.3.2	Peripheral Equipment .....	111
2.2.3.3	Patient Environment Equipment .....	112
2.3	Room Structural Requirements .....	112
2.3.1	General Policy.....	112
2.3.1.1	Baseplates Mounting .....	112
2.3.1.2	Substructure for Dual Arm suspension Mounting (for Mavig suspension with fixed point dual arm).....	114
2.3.2	Floor Requirements .....	114
2.3.2.1	Floor requirements when using provided floor anchors .....	114
2.3.2.2	Floor Construction Requirement .....	115
2.3.2.3	Hole dimension and preferred location in concrete floor .....	116

2.3.2.4	Water Pipes and Oil Hoses Requirements .....	118
2.3.3	Mounting Requirements .....	120
2.3.3.1	Positioner and Table Floor Mounting .....	120
2.3.3.2	Gantry Table Floor Preparation Kits (GE supplied) .....	127
2.3.4	Ceiling Requirements.....	127
2.3.4.1	Third Party Monitor suspension (option).....	127
2.3.4.2	Mavig suspension with rails .....	127
2.3.4.3	MAVIG suspension with fixed point dual arm .....	129
2.3.5	Wall Requirements .....	131
2.3.5.1	I-Box Installation .....	131
2.3.5.2	<b>(For IGS Control Center)</b> I-Points.....	132
2.3.5.3	Optional Large Display secondary monitor .....	133
2.3.5.4	V-Point .....	133
2.4	Seismic.....	134
<b>3</b>	<b>Special Construction Requirements.....</b>	<b>136</b>
3.1	Radiation Protection .....	136
3.2	Protection against electromagnetic interference hazards .....	136
<b>4</b>	<b>Environmental Requirements .....</b>	<b>145</b>
4.1	Humidity, Temperature and Altitude .....	145
4.1.1	Humidity.....	145
4.1.2	Temperature and Altitude .....	145
4.2	Heat Output.....	146
4.3	Acoustic Specifications .....	146
4.4	Room Light .....	147
4.4.1	Requirements for Lighting.....	147
4.4.2	Windows and Curtains .....	147
4.4.3	Surgical Lights .....	147
<b>5</b>	<b>Electrical Requirements .....</b>	<b>148</b>
5.1	System Electrical Ratings.....	148
5.2	Power Distribution Schematics .....	148
5.2.1	System with 8 kVA UPS .....	149
5.2.2	System with Fluoro UPS 11 kVA.....	150
5.2.3	System with 20 kVA Fluoro UPS.....	151
5.2.4	System with 20 kVA Fluoro UPS and IT Electrical Network .....	151
5.3	Cabling Requirements.....	152
5.3.1	Power Source Characteristics.....	153
5.3.1.1	Transformer.....	153
5.3.1.2	Power Cables (Feeders) .....	153
5.3.2	20 kVA Fluoro UPS Cables .....	154
5.3.2.1	20 kVA Fluoro UPS UL Power Cables .....	154
5.3.2.2	20 kVA Fluoro UPS CE Power Cables .....	154
5.3.2.3	20 kVA Fluoro UPS Ethernet Cable .....	155
5.3.3	EPO Cables and additional buttons .....	155
5.3.3.1	EPO Cable between the MDP and the PDU .....	155
5.3.3.2	Additional EPO buttons .....	155
5.4	Mains Disconnect Panel .....	158
5.4.1	General Information.....	158

5.4.1.1	Introduction .....	158
5.4.1.2	Pre-Installation .....	159
5.4.1.3	Spare Parts .....	159
5.4.2	Mandatory Construction Requirements .....	159
5.4.2.1	Input Power .....	159
5.4.2.2	Breakers.....	160
5.4.2.3	Terminal Blocks .....	160
5.4.2.4	Protective Earth .....	160
5.4.2.5	Indicators .....	161
5.4.3	Mandatory EPO Requirements .....	161
5.4.4	Mandatory LOTO Requirements .....	161
5.4.5	Mandatory Labeling Requirements.....	161
5.4.6	Other Mandatory Requirements.....	162
5.4.7	Preferred Schematics and Components.....	163
5.4.7.1	Recommended CE Schematics .....	163
5.4.7.2	Minimum Components Specifications for the CE MDP .....	165
5.4.7.3	Recommended UL Schematics .....	167
5.4.7.4	Minimum Components Specifications for the UL MDP.....	169
5.4.8	Checklist .....	171
5.5	External Interfaces.....	172
5.5.1	X-Ray ON lights.....	172
5.5.2	System ON light.....	173
5.5.3	Room lights .....	173
5.5.4	Room door interlock.....	174
5.5.5	Video distribution .....	175
5.6	Additional Full UPS.....	175
5.7	Grounding Schematics.....	175
5.8	Third-Party Monitor Suspension Typical Connections.....	177
5.9	System Cable Information .....	178
5.9.1	Physical Runs .....	178
5.9.1.1	Physical Run Synoptic .....	179
5.9.1.2	System Core Matrix .....	185
5.9.2	MIS (Master Interconnect System).....	196
5.9.3	Cable Channeling.....	197
5.9.3.1	General .....	197
5.9.3.2	Conduit.....	197
5.9.3.3	Electrical Ducts .....	197
<b>6</b>	<b>Communication Requirements.....</b>	<b>200</b>
6.1	Network Requirements .....	200
6.1.1	General Information.....	200
6.1.2	InSite-RSvP Connection Requirements .....	200
6.1.3	Connection Configuration Parameters .....	201
6.2	DICOM Requirements .....	202
6.3	Privacy and Security Configuration.....	202

# 1 General Requirements

## 1.1 Objectives & Overview

### 1.1.1 Object and Scope of this manual

#### Object and Scope

In this manual:

- The name "Allia™ IGS 5" is used to designate indifferently Allia™ IGS 3 or Allia™ IGS 5. In this case, the requirements are applicable indifferently to both products,
- The term "IGS system" refers to Allia™ IGS 3 and Allia™ IGS 5 product models.
- Allia™ IGS 3 is a product model based on Allia™ IGS 5.

This document is intended as a guide and information resource to properly plan and prepare a site for the installation of an IGS system.

In addition, this document provides references to the pre-installation documents of the various product included with the System.

These documents are intended to assist the Project Manager of Installation (PMI) and the Site Planner in properly preparing a site for the installation of this system.

It provides pre-installation data, such as site preparation prior to the delivery of the System, environmental and electrical requirements and some additional planning aids.

This revision introduces new power distribution configurations, on among the following would be installed:

- System Interface Cabinet – PDU V2 with 8 kVA UPS could be the legacy UPS 8 kVA Gen1 and the newly UPS 8 kVA Gen2.
- System Interface Cabinet – PDU V2 with 20 kVA Fluoro UPS.
- System Interface Cabinet – X-PDU with 11 kVA Fluoro UPS.

The term “UPS 8 kVA” is used to refer to both Gen1 and Gen2 models.

The term “PDU” is used to refer to both System Interface Cabinet PDU V2 and X-PDU.

#### WARNING



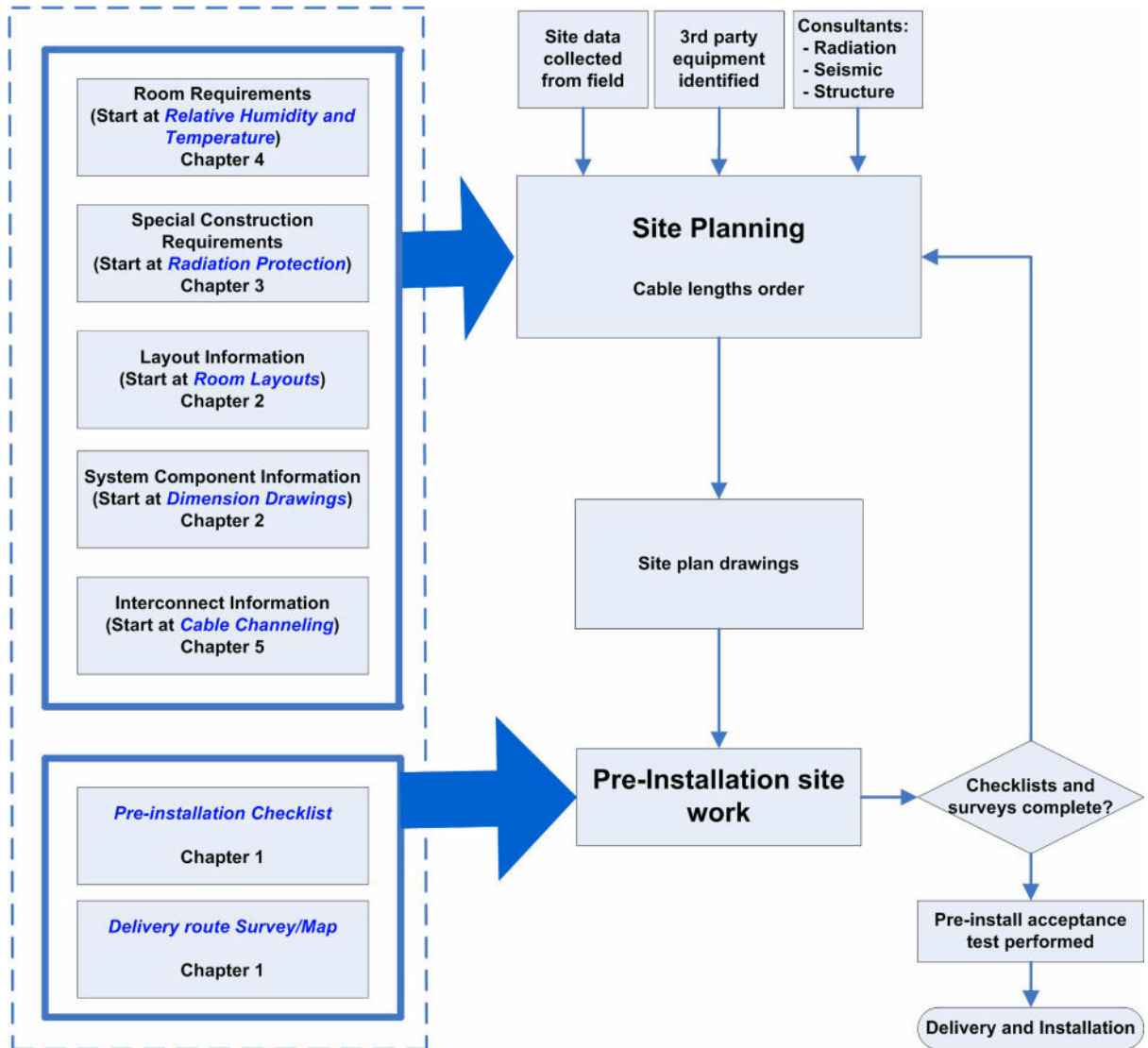
MAKE SURE THE ROOM PREPARATION COMPLIES WITH LOCAL REGULATIONS AS THE PIM IS NOT INTENDED TO REFLECT ALL OF THEM.

### 1.1.2 Pre-Installation Process

Complete the checklists in ROOM LAYOUTS, ELECTRICAL REQUIREMENTS, and GENERAL REQUIREMENTS of this manual. They represent an important part of the pre-installation process. The checklists summarize the required preparations and allow to verify the proper completion of the pre-installation procedures.

You will find hereafter a chart of the information flow in the pre-installation process.

Figure 1-1



## 1.2 Customer Responsibilities

### 1.2.1 Responsibilities of the Purchaser/Customer

To ensure that the installation of the System meets the purchaser or customer expectations, it is important to determine who will take responsibility for the various items during the system installation process. To help you in determining these responsibilities, review the following checklists with the customer and assign responsibilities as appropriate:

- [Tools and Test Equipment on page 28](#)
- [Pre-Installation Checklist on page 16.](#)

Contract Changes:

Be sure to inform the customer that the cost of any alteration or modification not specified in the sales contract are liable to the customer.

The following equipment must be installed by the Hospital's Contractors, per room drawings:

1. GE-supplied equipment:

- Gantry and Table baseplate with holes drilled (Per supplied template)
- Gantry and Table baseplate grout
- Gantry and Table baseplate floor anchors
- **(For Suspension with rails)** Monitor suspension stationary rails
- **(For Suspension with fixed point Dual Arm)** Substructure for Dual Arm Suspension (S18391MX)



**NOTE**

Means necessary to anchor of the Substructure for Dual Arm suspension (anchors, bolts, screws, etc.) are not delivered with the kit and should be provided and designed under customer responsibility.

2. Customer supplied equipment:

- MDP (Mains Disconnect Panel)
- Power cables MDP-PDU
- EPO cable MDP-PDU
- Protective Earth cable MDP-PDU



**NOTE**


In the case of the 11 kVA Fluoro UPS, all power cables are provided by GE HealthCare.


In the case of the 20 kVA Fluoro UPS, customer supplies:

- Power cable MDP to 20 kVA Fluoro UPS
- Power cable 20 kVA Fluoro UPS to PDU-V2
- **(For Suspension with fixed point Dual Arm)** Means necessary to anchor of the Substructure for Dual Arm suspension (anchors, bolts, screws, etc.)
- Third-Party Monitor suspension

## 1.2.2 Equipment Classifications

The following equipment classifications are applicable to the product:

Classification category	Equipment classification
Protection against electric shock	Class I  <div style="text-align: center;">  <p><b>WARNING</b></p> <p>TO AVOID THE RISK OF ELECTRIC SHOCK, THIS EQUIPMENT MUST ONLY BE CONNECTED TO A SUPPLY MAINS WITH PROTECTIVE EARTH.</p> </div>

Classification category	Equipment classification
Degree of protection against electric shock	<p><b>(For Omega and Innova IQ Table)</b></p> <p>Type B applied parts</p>  <p>Applied parts complying with the specified requirements of the IEC60601-1 standard to provide protection against electric shock, particularly regarding allowable patient leakage current and patient auxiliary current include:</p> <ul style="list-style-type: none"> <li>• Table Mattress</li> <li>• Table accessories and detachable parts: table head extender, clear-vu arm, head widener with pad/cushion, width extender with pad/cushion, armboard with thick pad/cushion, rail extender and patient restraint strap with cushion.</li> </ul> <p>Considered as applied parts: detector cover, removable rails (sleeve).</p>
Degree of protection against harmful ingress of water	<p>Ordinary equipment (enclosed equipment without protection against ingress of water, IPX0) except:</p> <ul style="list-style-type: none"> <li>• Footswitch (protected against the effects of permanent submersion, IPX8).</li> <li>• Innova<sup>IQ</sup> Table, Control Panel, Touch Panel, Table Panning Device (all protected against splashing, IPX4).</li> </ul>
Method(s) of sterilization or disinfection recommended by the manufacturer	<ul style="list-style-type: none"> <li>• Sterilization: not applicable</li> <li>• Disinfection: refer to User Manual (Chapter Safety and Regulatory, section Disinfection), Recommended disinfecting agents.</li> </ul>
Degree of safety of application in the presence of a flammable anesthetic mixture with air or with oxygen or nitrous oxide	<p>Equipment not suitable for use in the presence of a flammable anesthetic mixture with air or with oxygen or nitrous oxide</p> <p>The system does not fulfill the requirements for AP/APG classification (IEC60601-1)</p>
Mode of operation	Continuous operation with intermittent loading
Types of use/reuse	Multiple patient multiple use

**NOTICE**

THE SYSTEM CAN ONLY BE INSTALLED IN AN ANESTHETIZING LOCATION IF THAT LOCATION IS CLASSIFIED AS OTHER THAN HAZARDOUS AS PER NFPA 70 CLAUSE 517.60.

**NOTICE**

THE PRODUCT IS NOT CLASSIFIED AS AP, APG (EQUIPMENT NOT SUITABLE FOR USE IN THE PRESENCE OF A FLAMMABLE ANAESTHETIC MIXTURE WITH AIR OR WITH OXYGEN OR NITROUS OXIDE).

### 1.2.3 Pre-Installation Checklist

Refer to the document *Vascular Site Ready Checklist - DOC2949062* for standard HPM requirements on Room preparation for Vascular Systems installation.

See also the specific preparation requirements for IGS Systems installation given in sections 3, 4 and 5 of the Tab "Installation Prerequisites" in document *IGS System Installation Prerequisites - DOC2024755*.



**NOTE**

DOC2949062 and DOC2024755 are available from the Customer Documentation Portal.

## 1.3 Delivery Requirements

### 1.3.1 Shipping Information

#### 1.3.1.1 Product Shipping Information

Refer to the table below. To obtain shipping information for components not specified in the table, refer to the appropriate component Pre-Installation Manual.

**Table 1-1**

PRODUCT OR COMPONENT	DIMENSIONS			WEIGHT kg (lbs)	METHOD OF SHIPMENT
	Height mm (in)	Width mm (in)	Depth mm (in)		
Gantry Dolly Packaging (Gantry full configuration (on dolly) + pallet)	2300 (90.5)	1380 (54.5)	2900 (114)	1200 (2,645) (see **)	Air shipment. See <a href="#">Figure 1-4 Gantry Air Shipment on page 21</a>
Gantry (shipping & moving): Full configuration	2000 (79) (see *)	1230 (48.4)	2820 (111)	940 (2,072) (see **)	Shipping Dolly. See <a href="#">Figure 1-2 Gantry on Shipping Dolly - Delivered configuration on page 19</a>
Gantry (moving): Short lifts configuration	2000 (79)	1160 (46)	2300 (90)	780 (1,720) (see **)	See <a href="#">Figure 1-3 Gantry on Shipping Dolly - On-site shortened configuration on page 20</a>
C-FRT Cabinet	2200 (87)	1500 (59)	850 (34)	618.6 (1,362)	On pallet. See <a href="#">Figure 1-5 C-FRT Cabinet Shipment on page 22</a>
PDU V2	2022 (79.6)	984 (38.7)	950 (37.4)	353.5 (778)	On pallet. See <a href="#">Figure 1-6 PDU V2 or X-PDU Shipment on page 23</a>
X-PDU Cabinet	2022 (79.6)	984 (38.7)	950 (37.4)	310 (683.4)	On pallet, see <a href="#">Figure 1-6 PDU V2 or X-PDU Shipment on page 23</a>
Omega Table Base Assembly	1035 (41)	2060 (81)	840 (33)	585 (1,290)	On pallet. See <a href="#">Figure 1-7 Omega Table Shipment on page 24</a>
Omega Table Top Assembly	220 (9)	3470 (137)	840 (33)	70 (155)	On pallet. See <a href="#">Figure 1-7 Omega Table Shipment on page 24</a>

Table 1-1 (Table continued)

PRODUCT OR COMPONENT	DIMENSIONS			WEIGHT kg (lbs)	METHOD OF SHIPMENT
	Height mm (in)	Width mm (in)	Depth mm (in)		
Innova <sup>IQ</sup> Table Base Assembly and covers	1160 (45.7)	1000 (39.4)	2150 (84.6)	750 (1,653)	On pallet. See <a href="#">Figure 1-8 Innova<sup>IQ</sup> Table Shipment on page 25</a> and <a href="#">Figure 1-9 Covers Shipment on page 25</a>
X-Ray Tube Cooling Unit	730 (28.7)	990 (39)	500 (10.7)	98 (216)	On pallet
Detector Conditioner	550 (21.6)	470 (18.5)	350 (13.7)	17.6 (38.8)	On pallet
Gantry Requisites	-	-	-	-	On pallet
Cables	-	-	-	-	On pallet
Monitor susp. bridge	640 (25.2)	980 (38.6)	3060 (120.5)	210 (445)	On pallet
Monitor susp. rails	380 (15)	300 (12)	5960 (235)	160 (355)	On pallet
Large Display monitor (without integrated protective screen)	895 (35.2)	1390 (54.7)	275 (10.8)	45 (99.2)	On pallet
Large Display monitor (with integrated protective screen)	895 (35.2)	1390 (54.7)	275 (10.8)	54.5 (120.2)	On pallet
LD suspension with rails	1100 (43.3)	1100 (43.3)	1850 (72.8)	390 (860)	On pallet
LD suspension with rails 36 m harness	230 (9)	800 (34.5)	800 (34.5)	62 (134)	On pallet
Substructure for Dual Arm suspension (for Mavig suspension with fixed point dual arm for Large Display Monitor)	330 (13)	1040 (41)	490 (19.3)	70 (154.3)	On pallet, see <a href="#">Figure 1-10 Shipment of Substructure for Dual Arm suspension on page 26</a>
Mavig suspension with fixed point dual arm for Large Display Monitor	1860 (73.2)	2150 (84.6)	900 (35.4)	370 (815.7)	On pallet, see <a href="#">Figure 1-11 Large display MAVIG suspension with fixed point dual arm Shipment on page 27</a>
20 kVA Fluoro UPS UL	2100 (82.7)	890 (35)	1000 (39.4)	561 (1,235)	On pallet
20 kVA Fluoro UPS CE	1460 (57.5)	540 (21.3)	857 (33.8)	293 (645)	On pallet
8 kVA Gen1 UPS	2100 (82.6)	640 (25.2)	1040 (40.9)	97 (214 lbs)	On pallet
8 kVA Gen2 UPS	700 (27.6)	640 (25.2)	1040 (40.9)	91 (200.6)	On pallet
Fluoro UPS (11 kVA)	700 (27.6)	640 (25.2)	1040 (40.9)	91 (200.6)	On pallet
IGS Control Center not equipped (option for Innova <sup>IQ</sup> Table)	1700 (66.9)	700 (27.6)	700 (27.6)	46 (101.4)	On pallet
<b>(For IGS Control center)</b> System cables group Cart option	-	-	-	45 (99)	On pallet



**NOTE**

\*: Height can be adjusted: ONLY when necessary on delivery path and IF floor rolling surface is flat and leveled (no obstacle), Dolly can be lowered down by 120-130 mm (it means dolly horizontal bars are at 10 mm from floor surface, to prevent any damage on gantry).

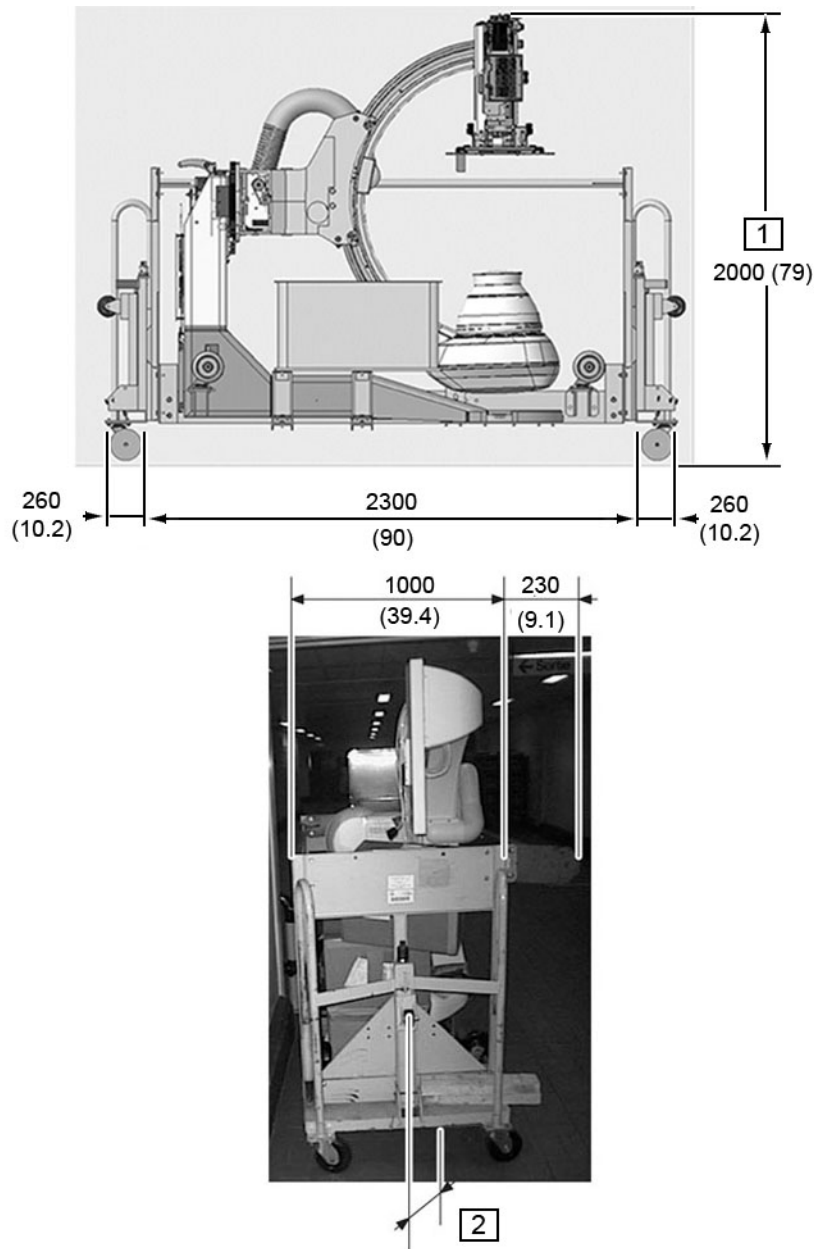
\*\* : If detector is shipped in a separate package, otherwise 29 kg are added.

### 1.3.1.2 Detail of Shipping Information

#### 1.3.1.2.1 Gantry Shipment

#### Gantry on Shipping Dolly

Figure 1-2 Gantry on Shipping Dolly - Delivered configuration

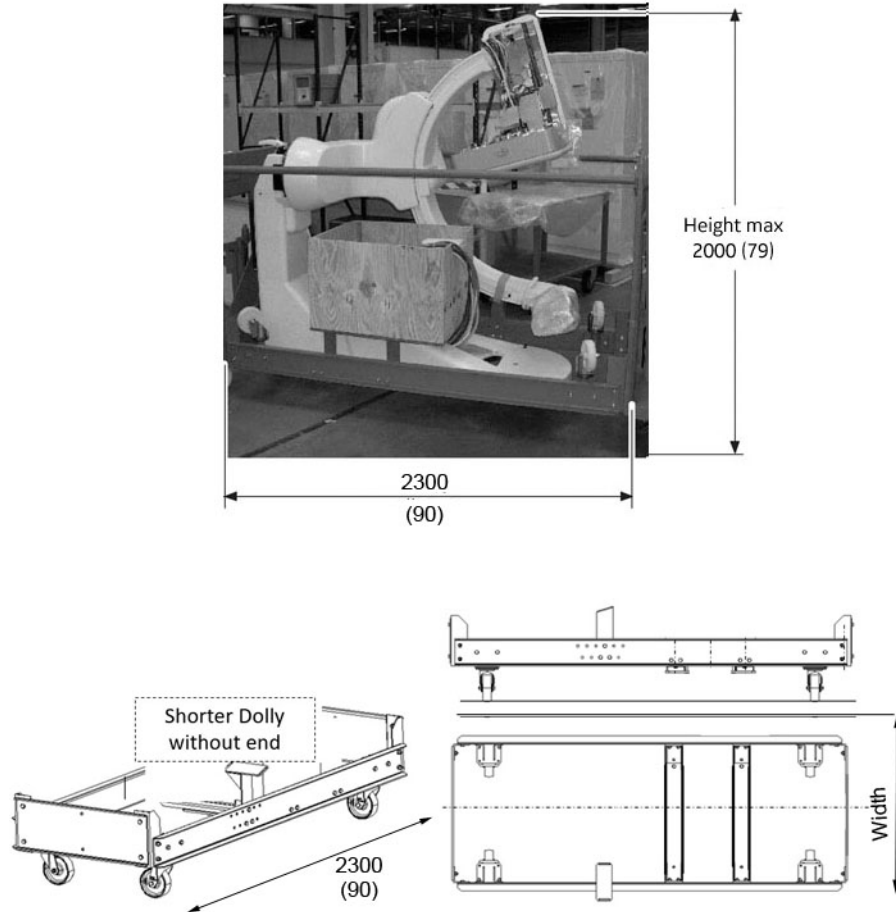


Dimensions in mm (in)

Item	Description
[1]	Maximum height
[2]	≈ 300 mm (12) with caster

If the shipping dolly depth is too large you may need to remove the two lift ends and the right and left top handles.

**Figure 1-3 Gantry on Shipping Dolly - On-site shortened configuration**



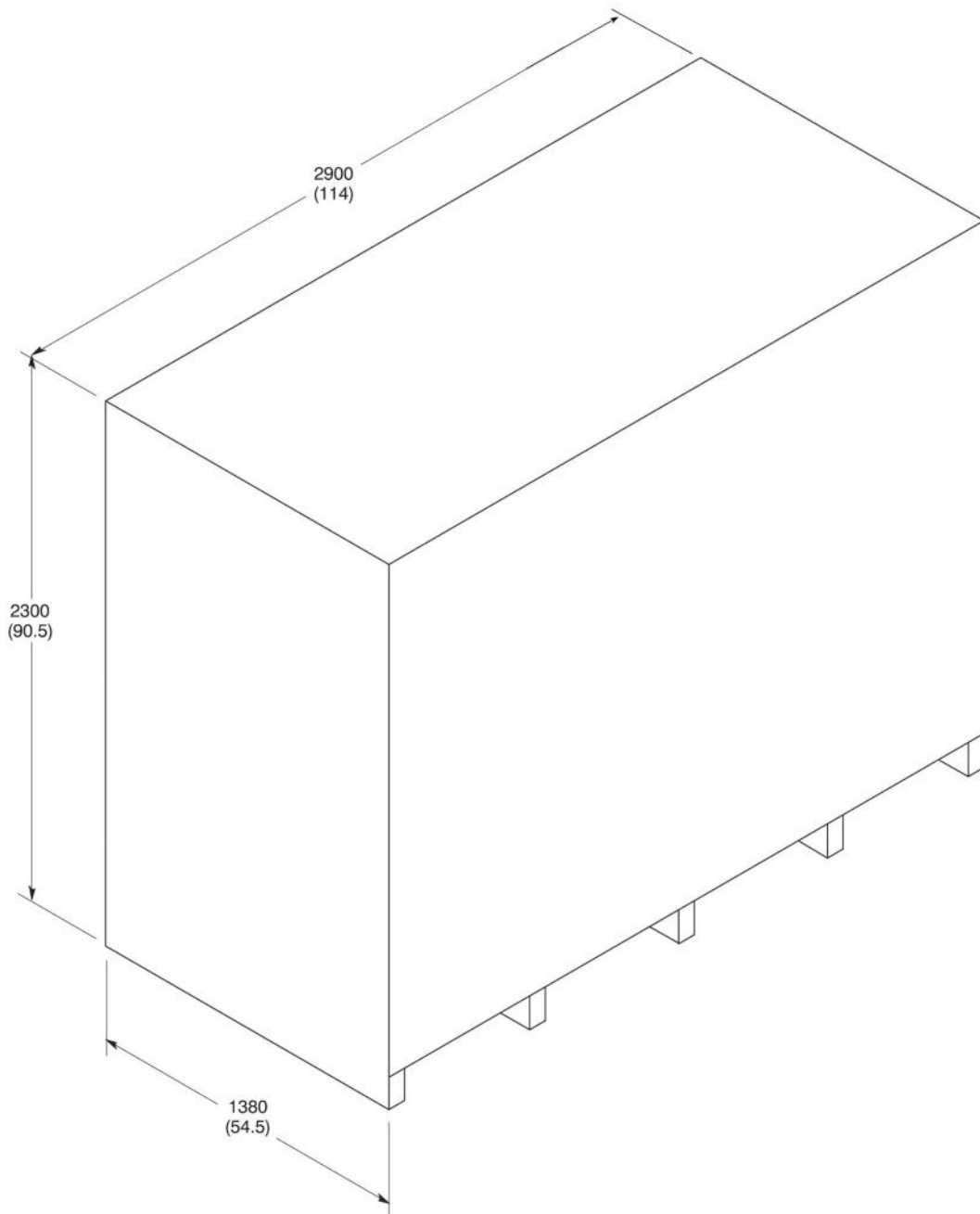
Dimensions in mm (in)

**Table 1-2 Gantry on Shipping Dolly - On-site shortened configuration**

Max width with Gantry mm (in)	Length mm (in)	Height mm (in)
1160 (46)	2300 (90)	2000 (79)

## Gantry Air Shipment

Figure 1-4 Gantry Air Shipment



DIMENSIONS IN MM (INCHES)


NOT TO SCALE

### 1.3.1.2.2 C-FRT Cabinet Shipment

Figure 1-5 C-FRT Cabinet Shipment

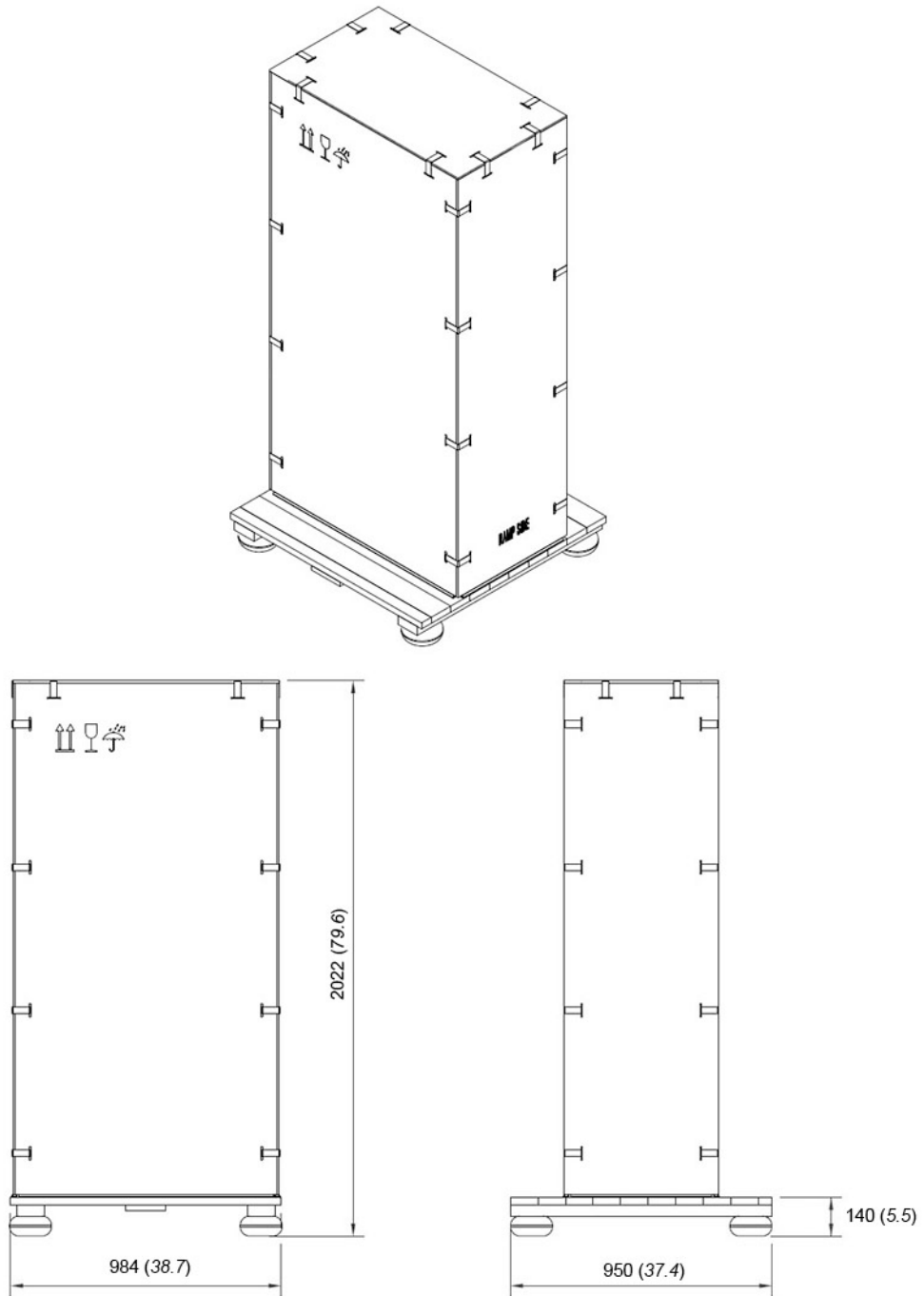


Dimensions in mm (in)

 **NOTE** Pallet is delivered as part of C-FRT Cabinet packaging.

### 1.3.1.2.3 PDU Shipment

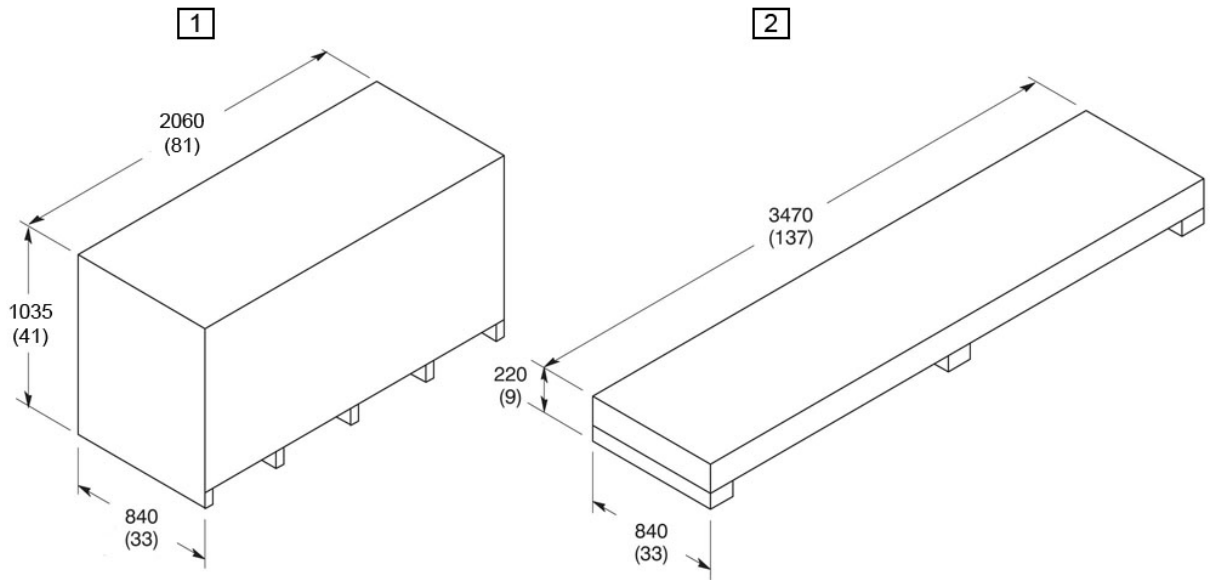
Figure 1-6 PDU V2 or X-PDU Shipment



Dimensions in mm (in)

### 1.3.1.2.4 Omega Table Shipment

Figure 1-7 Omega Table Shipment

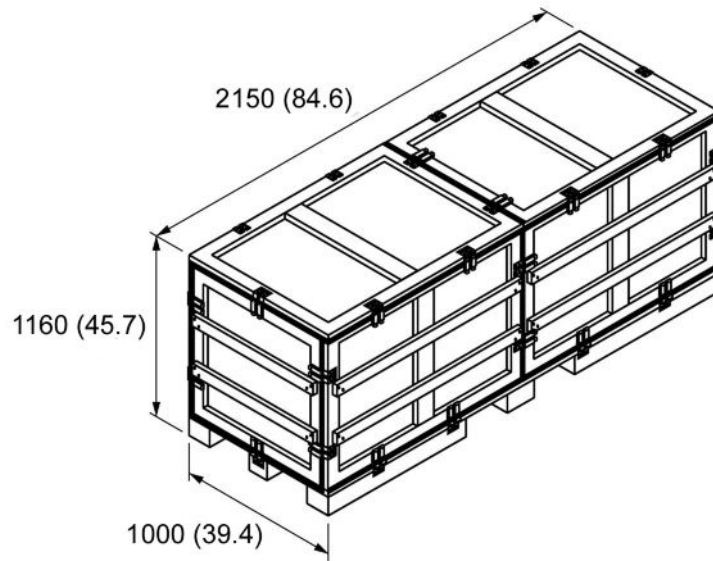


Dimensions in mm (in)

Item	Description
[1]	Base assembly
[2]	Table top assembly

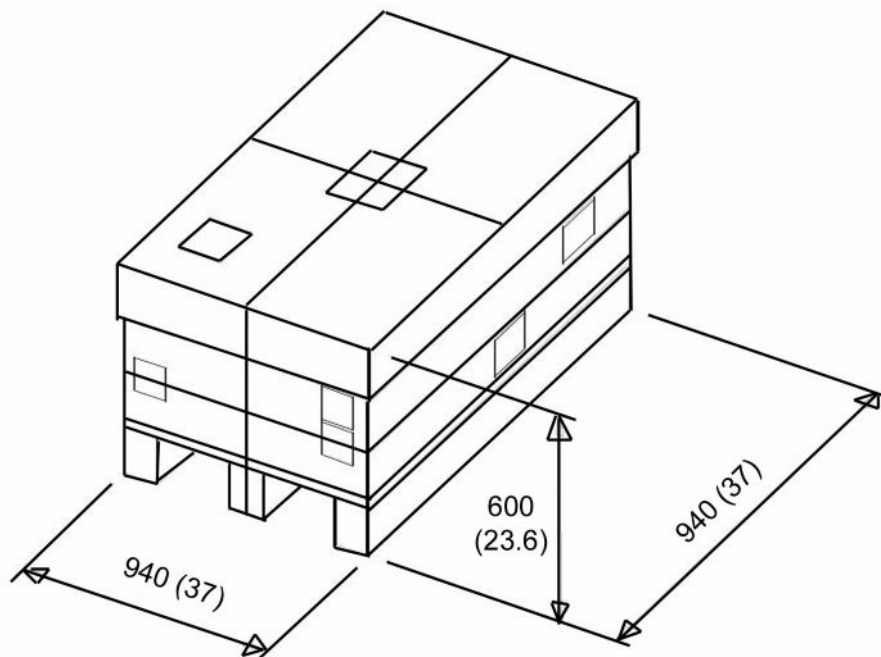
### 1.3.1.2.5 Innova<sup>IQ</sup> Table Shipment

Figure 1-8 Innova<sup>IQ</sup> Table Shipment



All dimensions are in mm (inches)

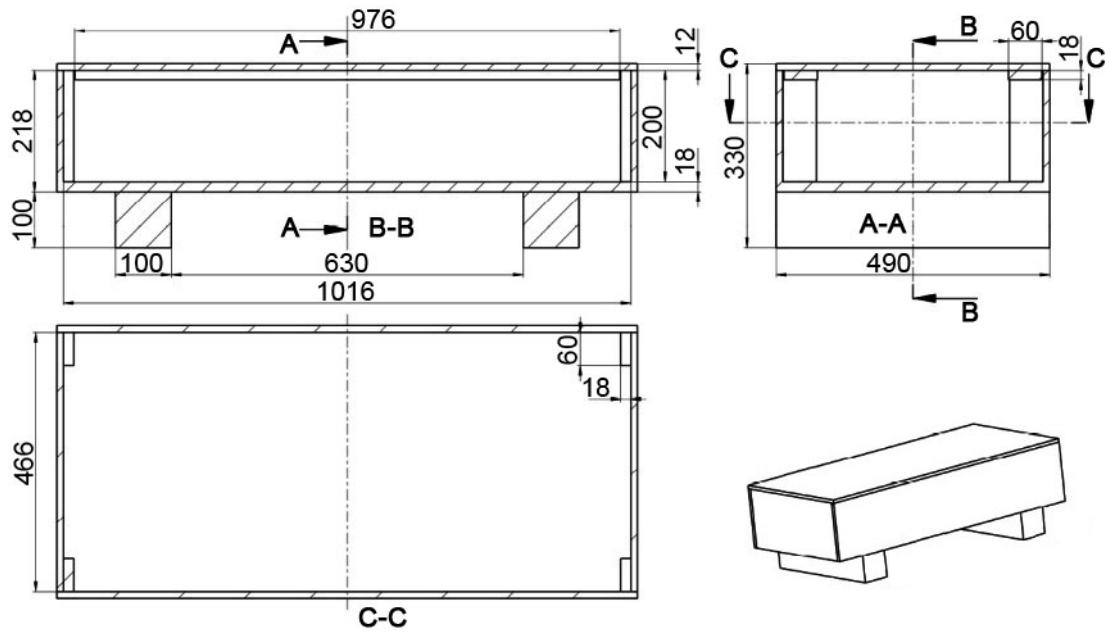
Figure 1-9 Covers Shipment



All dimensions are in mm (inches)

### 1.3.1.2.6 Monitor suspension with fixed point dual arm Substructure for Dual Arm suspension

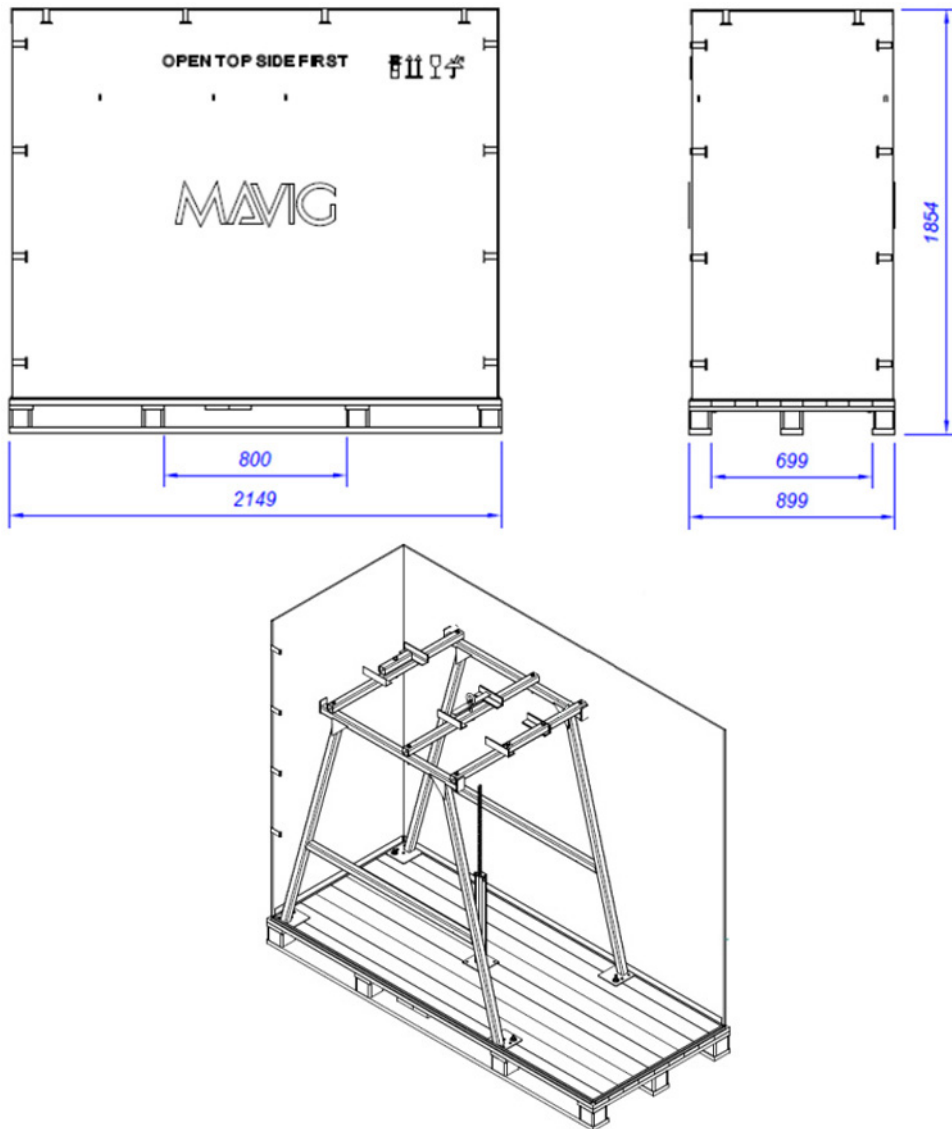
Figure 1-10 Shipment of Substructure for Dual Arm suspension



Dimensions in mm

## Mavig suspension with fixed point dual arm for Large Display Monitor

Figure 1-11 Large display MAVIG suspension with fixed point dual arm Shipment



Dimensions in mm

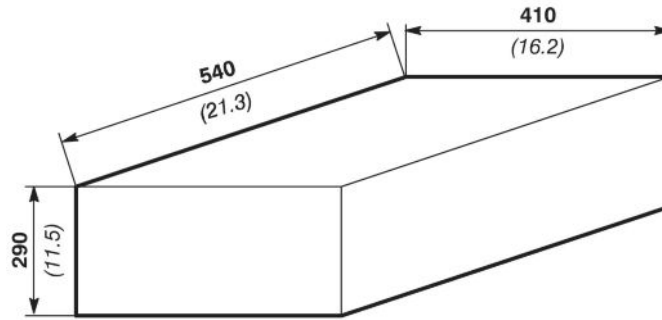
### 1.3.1.2.7 Other Elements Package



**NOTE**

All OEM parts are shipped inside their original boxes group as needed on pallets.

**Figure 1-12 Other Standard Shipping Box**



Dimensions in mm (in)

### 1.3.2 Tools and Test Equipment

Refer to [Table 1-3 on page 28](#). To obtain a list of tools and test equipment for components not specified in [Table 1-3 on page 28](#), refer to the appropriate component Pre-Installation Manual.

**Table 1-3**

PRODUCT OR COMPONENT	TOOLS	USED FOR	SOURCE	RECEIVED (DATE)
All	Service Engineer's Tool Case	General Use		
LC Positioner	Level, Protractor Type	Positioner Checks		
	Torque Wrench 2 to 20 daN.m (15 ft. lbs. to 150 ft. lbs.)	Positioner Checks		
	1/2 inch Ratchet Wrench	Raise and Lower Positioner shipping dolly		
	Laptop Computer	Positioner Configuration and Calibration		
Omega/Innova <sup>IQ</sup> Table	Same as for LC Positioner (Service Engineer's Tool Case) Fill in any additional tools or test equipment as required			
	Installation dolly (PN 5265134)	Installation		
Monitor Suspension	Ladders	Installation		
	<b>(For Suspension with rails) XT Lifting Tool (x2) 46-156940G3</b>	Installation		
	<b>(For Suspension with fixed point Dual Arm for LDM)</b> <ul style="list-style-type: none"> <li>• Installation tool and Pelicase (P/N 5758418)</li> <li>• Torque wrench 200 N.m (150 ft.lbs)</li> </ul>	Installation		

## Test Equipments and documentation to store in hospital

All dimensions are in mm and (inch).

- Accessories X-Ray tube cooling unit (to be stored at technical room):
  - 3 boxes : each H x W x D = 210 (8.3) x 400 (15.7) x 310 (12.2)



- Service tools (to be stored in technical room):
  - 2 boxes : each H x W x D = 80 (3.1) x 470 (18.5) x 470 (18.5)



- Suit Cases (to be stored near the exam room as required during calibration procedures):
  - **3D:** H x W x D = 460 (18.1) x 770 (30.3) x 580 (22.8)



- **Positioner:** H x W x D = 90 (3.5) x 340 (13.4) x 260 (10.2)
- **Composite phantom:** H x W x D = 180 (7.1) x 470 (18.5) x 360 (10.2)
- **X-Ray beam accessories:** H x W x D = 130 (5.1) x 450 (17.7) x 380 (15)
- **QAP:** H x W x D = 460 (18.1) x 570 (22.4) x 380 (15)



- Documentation maps (control room or technical room):
  - H x W x D = 330 (13) x 500 (19.7) x 310 (12.2)



### 1.3.3 Door Size Requirements

Minimum door sizes also apply to hallways and elevators. For additional details, refer to [1.3.1 Shipping Information on page 17](#).

#### Door Height

The minimum doors height shall be determined to accommodate for the following components:

- The Gantry on its dolly: **2 m** (79 in).
- The C-FRT Cabinet on its pallet: **2.20 m** (87 in).

If the door height is not sufficient, you may need to put the C-FRT Cabinet on its wheels (refer to Dimension Drawings [Figure 2-32 C-FRT Cabinet - Dimensions and CoG on page 74](#) and to *IST0527 - C-FRT Cabinet Installation* in the Service Manual.

#### WARNING



Adhere to the limit of use described in the Installation Job card.

#### Door Width

The minimum door width needed (to accommodate the LC shipping dolly) is **1.23 m** (48.4 in) in delivery configuration or **1.16 m** (46 in) in on-site shortened configuration.

#### NOTE

Door widths are based on a straight-in approach requiring a 2.44 m (96 in) wide corridor. Calculations need to be made for accommodation of equipment through narrower corridors.

## Elevator Depth

The minimum elevator depth needed to accommodate the Gantry shipping dolly is:

- **2.82 m** (111 in) with the Gantry shipping dolly in delivery configuration.
- **2.30 m** (90 in) with the Gantry shipping dolly in shortened configuration.

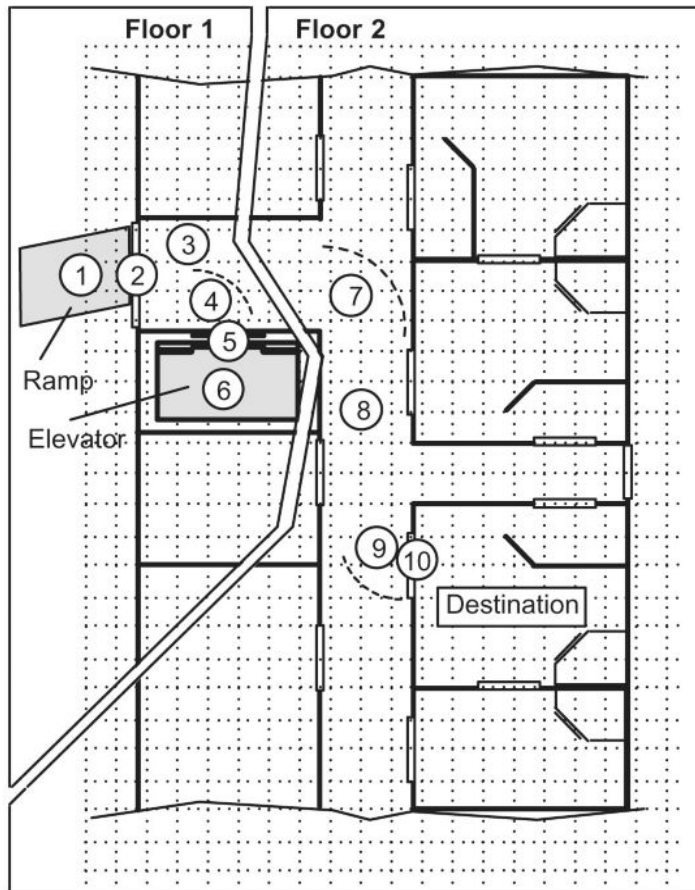
## 1.3.4 Route Survey

### Step One – Sketch

Start preparing Route Survey by sketching a floor plan of the hospital or clinic which will receive the equipment. Include all areas on the delivery route from outside the building to destination. See [Figure 1-13 on page 31](#).

Reference Numbers: Numbers in circles refer to Route Survey data. The Route Survey is a form on which site data are listed (see [Step Two – Survey on page 31](#)).

**Figure 1-13**



### Step Two – Survey

Data concerning the intended delivery route are recorded on the Route Survey in the following pages. Record all loading capacities, corridor widths, door openings, turning radii, flooring materials, elevator sizes, obstructions and so on.

### Step Three – Check

Verify equipment can be transported via the route specified in [Step One – Sketch on page 31](#). Compare Route Survey compiled in [Step Two – Survey on page 31](#) to equipment specifications in this and other applicable pre-installation directions.



**Table 1-6 Storage Requirement**

Component	TEMPERATURE		HUMIDITY		PRESSURE	
	MIN	MAX	MIN	MAX	MIN	MAX
All components	+10°C (+50°F)	+40°C (+104°F)	10%	80%	700 hPa	1030 hPa

It is recommended that the temperature for storage does not exceed +25°C (+77°F).

Systems with the 20 kVA Fluoro UPS shall be stored for less than 6 weeks if the storage temperature is above 30°C (86°F), and less than 12 weeks if the storage temperature is above +25°C (+77°F).

Systems with the 8 kVA UPS or Fluoro UPS (11 kVA) shall be stored for less than 14 weeks if the storage temperature is above 30°C (86°F), and less than 25 weeks if the storage temperature is above +25°C (+77°F).

The overall storage time for the system shall be less than 6 months.

**Special instructions for the detector:**

The detector is very sensitive to temperature and humidity, as irreparable damage to the detector scintillator will occur. If the detector is shipped in a separate package, as defined in [Table 1-6 Storage Requirement on page 33](#), it shall be stored between +10 and +40°C (+50 to +104°F) and less than 80% RH inside its unopened shipping box, the lowest temperature and humidity being preferable. If it is to be stored outside of its shipping box or if the plastic wrapping has been removed, it should be stored at +20°C (68°F) or less and 30% RH or less.

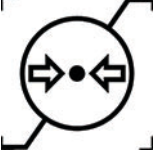



**1.4.3 Handling instructions**

The system can be shipped and stored in multiple packaging, with special handling instructions for transport defined using the following symbols:

**Table 1-7**

Symbol	Meaning
	The contents of the transport package are fragile and the package shall be handled carefully
	The transport package shall be kept away from rain and in dry conditions
	Maximum and minimum temperature limits at which the item shall be stored, transported or used
	Acceptable upper and lower limits of relative humidity for transport and storage

**Table 1-7** (Table continued)

Symbol	Meaning
	Acceptable upper and lower limits of atmospheric pressure for transport and storage
	Marked item or its material is part of a recovery or recycling process
	The items shall not be vertically stacked, either because of the nature of the transport packaging or because of the nature of the items themselves
	Correct upright position of the transport package

## 2 Equipment Requirements

### 2.1 System Components

#### 2.1.1 Presentation of the 3 Rooms

The components shall be installed in three different rooms with different constraints: the Exam Room, the Control Room and the Technical Room.

##### **Exam Room**

This is where the patient is situated. It contains the table on which the patient is lying, the user interfaces, the gantry, the exam monitors, and accessories.

##### **Control Room**

This room contains user interface and control monitors. No intentional or unintentional contact with the patient shall occur with the patient in this area.

##### **Technical Room**

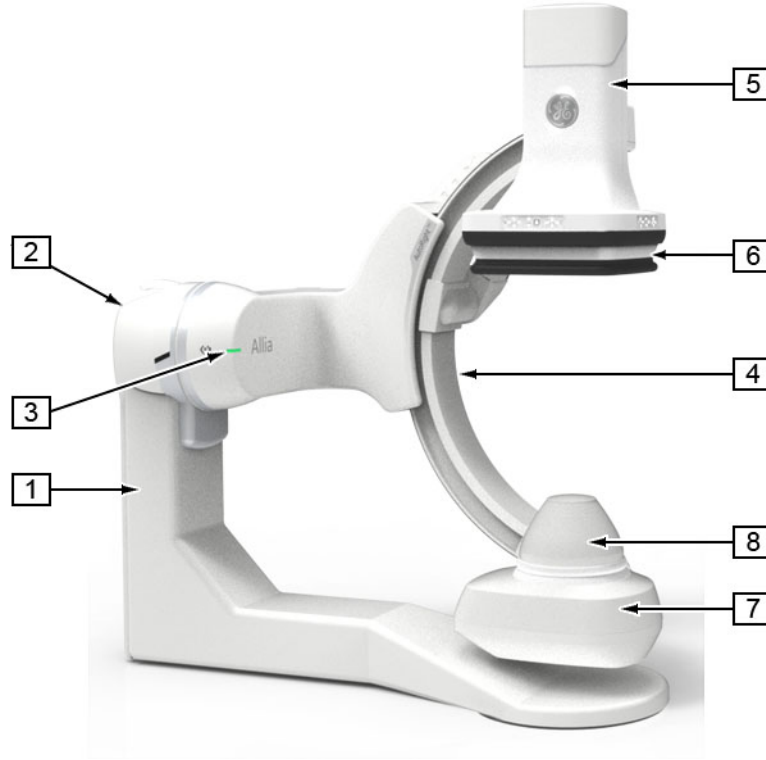
This room contains all electronic cabinets. No intentional or unintentional contact with the patient shall occur with the patient in this area. This room shall be separated from the Exam Room and the Control Room, in order to minimize risks of transmission of airborne pathogens. It is recommended to keep the technical room door locked. Its construction should be adapted to minimize ambient noise level; for example the use of glass doors instead of louvered hung doors.

## 2.1.2 Description of the System

### 2.1.2.1 Core System

#### 2.1.2.1.1 Gantry

Figure 2-1 Gantry



1. L-arm
2. Pivot
3. X-Ray LED
4. C-Arc
5. Motorized Elevator for the Detector
6. Detector 20 cm or 30 cm
7. X-Ray Tube Performix™ Pulsar
8. Collimator

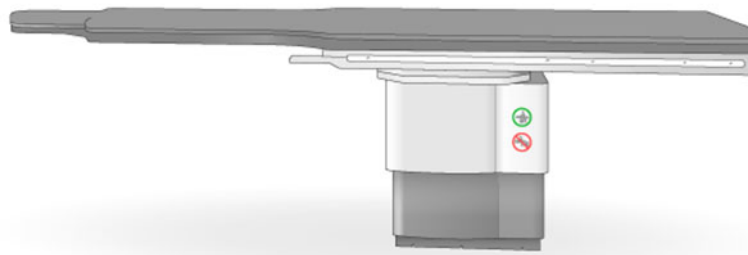
#### 2.1.2.1.2 Patient Table

Patient Table depends on your System.

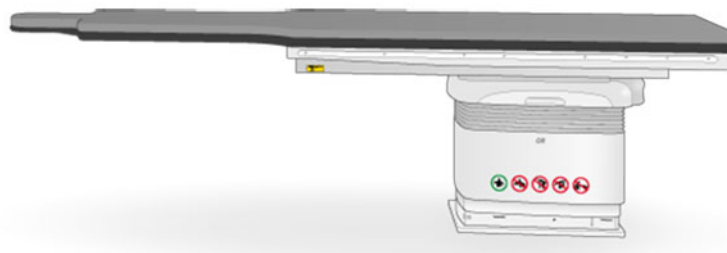
Table 2-1 Compatibility matrix for Patient Table

	Allia IGS 330	Allia IGS 520	Allia IGS 530
OMEGA IV Compact Table	No	Yes	No
OMEGA V long Table	Yes	Yes	Yes
Innova <sup>IQ</sup> Table	No	Yes	Yes

**Figure 2-2 Omega Table**



**Figure 2-3 Innova<sup>IQ</sup> Table**



### 2.1.2.1.3 User Interfaces

Figure 2-4 User Interfaces



Item	Description
[1]	Control Panel
[2]	Touch Panel
[3]	Table Footswitch
[4]	Table Panning Device (TPD)
[5]	VCIM with DL Keyboard Console
[6]	DLX Keypad
[7]	DL Remote Control

### 2.1.2.1.4 Accessories for Innova<sup>IQ</sup> Table in Surgical configuration

Figure 2-5



Item	Description
[1]	Anesthetic Screen Holder
[2]	Round Post clamp
[3]	Sleeve
[4]	Arm Board

Figure 2-6



Item	Description
[1]	Cart
[2]	Head Widener
[3]	Universal Clamp
[4]	Width Extender
[5]	Patient Restraint Strap
[6]	Rail Extender
[7]	User Interface Adaptor Rail

### 2.1.2.1.5 Monitors

By default, the system is provided with:

- a 55” Large Display Monitor (LDM) and 2 backup 19” monitors in the Exam Room. It can display up to 8 video sources simultaneously at different sizes based on stage of workflow. The predefined video layouts are selectable from the Touch Panel. The number of inputs is 8 by default, it can be extended to 18 with an optional video matrix (in the C-FRT cabinet).

- two 19" monitors in the Control Room:
  - LIVE monitor,
  - DL monitor.

### 2.1.2.1.6 Electronic Cabinets and Equipment

The following cabinets and equipments are provided with the system:

- C-FRT Cabinet, which contains the high voltage generator, 2 PCs, the Large Monitor Manager, IT components and the boards for the Gantry and Table control.
- Power distribution, one among:
  - System Interface Cabinet – PDU V2 with UPS 8 kVA to maintain all functions except X-ray acquisitions during power failures, or 20 kVA Fluoro UPS to complete an exam in fluoroscopy mode during power failures
  - System Interface Cabinet – X-PDU with Fluoro UPS 11 kVA to complete an exam in fluoroscopy mode during power failures
- Cooling Unit for X-ray Tube.
- Detector Conditioner.
- I-Box.
  - **(For System with Omega Table)** mandatory.
  - **(For System with Innova IQ Table)** provided only with the IGS Control Center option.

## 2.1.2.2 Options

### 2.1.2.2.1 V-Point

The V-Point is a fixed video input for a third party device, located in the Exam Room or in the Control Room. It allows to display the image of this third party device on the LDM. Up to three V-Point can be installed.

The V-Point is compatible with DVI-D (digital only). The maximum supported resolution is 1920 x 1200 60 Hz.

The V-Point can be installed on a wall or on a boom. When installed on the wall, the V-Point **[1]** shall be installed with its box **[2]**.

The V-Point shall not be installed under the table.

Figure 2-7 V-Point Option



The maximum distance between the V-Point and the C-FRT cabinet is 36 m. The diameter of the cable is 20 mm. The routing of the cable shall respect a minimum bending radius of 30 mm when installed on the wall and a minimum dynamic bending of 50 mm radius when mounted on a boom.

### 2.1.2.2.2 User Interfaces

The user interfaces available on option in the Exam Room are:

- Bolus Handle [1].
- Wireless Footswitch [2].
- **(For System with Omega Table)** Touch Panel 2nd set.

Figure 2-8 Optional User Interfaces



**(For System with Innova<sup>IQ</sup> Table)** On option, the Control Panel and the Touch Panel can be installed on the IGS Control center. The IGS Control Center is connected to one of the 2 I-Points of the Exam Room.

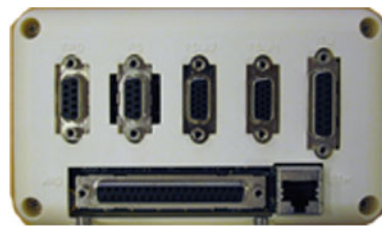
**Figure 2-9 IGS Control Center**



The user interface available on option in the Control Room is:

- Remote Control Panel connected to the system with the Remote Box.

**Figure 2-10 Remote Box**



1



2

Item	Description
[1]	Remote Box for Omega table
[2]	Remote Box for Innova <sup>IQ</sup> table

**2.1.2.2.3 Monitors**

A second LDM can be provided with the system. The suspension for this monitor shall be provided by the customer.

Up to 6 optional 19" monitors can be installed:

- 1 additional 19" monitor in the Exam Room (Roadmap),
- up to 2 additional 19" monitors in the Control Room (Review and Roadmap),
- up to 3 additional 19" monitors in the Exam Room or in the Control Room.

**Table 2-2 Location of 19" monitors (mandatory and optional) - With LDM**

Video Splitter Output	Output 1	Output 2	Output 3	Output 4
Live	<b>Exam Room</b>	<b>Control Room</b>	Exam Room or Control Room	<b>LDM</b>
Review	<b>Exam Room</b>	Control Room	Exam Room or Control Room	<b>LDM</b>
Roadmap	Exam Room	Control Room	Exam Room or Control Room	<b>LDM</b>



**NOTE**

Text in **bold** indicates the outputs used in the default configuration (core system).

**2.1.2.2.4 Monitor Suspensions**

GE HealthCare provides as option several types of suspensions; alternatively, the customer can install the suspension of his choice (third party monitor suspension), provided all requirements in the paragraph [2.1.2.2.4.2 Third Party monitor suspension according to GE HealthCare specifications on page 44](#) are met.

**2.1.2.2.4.1 LDM suspension**

The system can be equipped with one of the following suspensions:

- a suspension with rails
- a suspension with fixed point dual arm.

These suspensions are delivered and installed by GE HealthCare.

The two backup monitors are mounted on the back of this suspension for faster access in case of failure.

**2.1.2.2.4.2 Third Party monitor suspension according to GE HealthCare specifications**

The IGS system can be provided with one or several kits to interface third-party suspensions in addition or in replacement of the standard Mavig Suspension usually provided with the system. These kits provide the power and signal connections for the 19" monitors and the Large Display monitor, and for the infra-red receiver.



**The association of the IGS system or the purchaser’s suspension(s) is not covered by the GE HealthCare product certification.**

**The overhead monitor suspension shall be installed by strictly following the GE HealthCare installation instructions. GE HealthCare specifically disclaims any and all liability arising out of or relating to the use or performance of the monitor suspension (including cables), including, without limitation, any liability or claims relating to patient injury, death, or the reliability of such monitors suspension.**

**The mechanical installation of the third-party suspension and the electrical installation of the third-party monitors are fully under the customer and the installer responsibility. They shall ensure that the third-party suspension and its cables are installed prior to the GE HealthCare equipment (gantry, table, cabinet) so that the standard GE HealthCare Service Process can be followed during the system installation. Monitors installation and connections to the GE HealthCare equipment shall only be made in presence of a GE HealthCare service representative.**

**The electrical installation of the third-party monitors is fully under customer and installer responsibility.**

**The installer is responsible for ensuring that all requirements from this document are met.**

It is recommended that the vendor contacts GE HealthCare Service representative and reviews the site planning details before the suspension is installed. The position of each suspension in the exam room shall be planned following the recommendations from the chapter Room Layout, in order to reduce the risk of collision between any fixed part of the suspension and the gantry or table.

In addition, the location of each suspension in the exam room shall be compatible with the maximum cable length defined in the tables after.

**NOTE**

GE HealthCare will not be responsible for any delay in installation if the suspension is not mounted and its cables routed before GE HealthCare parts arrive on site.

The customer is responsible for providing and replacing any parts of the Third-party Suspension and of the third-party monitors.

Installation requirements:

- The live and roadmap 19" monitors are mandatory in the exam room.
- In order to maintain the IQ performance of the system, only the video cables provided in the kit shall be used to display images on the monitors provided with the system. No extension or additional restpoint is allowed.
- The CAT video cables for the 19" monitors shall respect a minimum bending radius of 24 mm whatever the position of the suspension.
- The CAT video cables for the LDM shall respect a minimum bending radius of 35 mm whatever the position of the suspension.

It is the customer responsibility to ensure that the following requirements are met.

- Each suspension shall not be electrically motorized for up/down motion.
- Each suspension shall comply with the IEC 60601-1 standard and the applicable standards enforced in the country of installation (e.g. when installed in a European Community country, the suspension(s) shall be CE marked). In addition, for North America each suspension shall comply with UL/Canada deviations.
- Each suspension shall be manually adjustable in height and the force to be applied to lift the suspension when fully equipped shall not exceed 200 N in static in the vertical axis, in order to mitigate the risk of patient jammed between table and monitor suspension when the table is lifted up.
- Each suspension shall be installed in order to mitigate the risk of suspension fall on patients and the risk of collisions with the gantry, the table or any other suspension.
- The weight of the monitors and other parts attached to the suspension shall be in accordance with the maximum load supported by the suspension. See [2.1.2.3 Components location and characteristics on page 48](#) for weight and dimensions. For type of fixation:
  - 19" monitors: VESA 100 x 100 mm.
  - Large Display Monitors: VESA 400 x 400 mm.
  - IR Receiver module: VELCRO.
- Each suspension shall be attached to the ceiling in accordance to the manufacturer's instructions. It shall withstand the maximum suspension load with safety factors in accordance to applicable standards (at least four).
- Each suspension shall be compatible with the chapter Environmental Requirements.
- When the system is installed in an operating room (Surgical configuration), each suspension shall be compatible with surgical environmental constraints.

**NOTICE**

IT IS MANDATORY TO EXECUTE THE GROUNDING CONTINUITY AND THE LEAKAGE CURRENT MEASUREMENTS AS DEFINED IN CHAPTER 5 AND 6 OF *THIRD-PARTY MONITOR SUSPENSION SERVICE INSTRUCTION FOR INSTALLATION*.

The kits to interface a third-party suspension contain the following cables:

**Table 2-3 Kit for the LDM suspension: all cable length 36 m (34.5 m usable length)**

From	To	Cable
PDU	monitors	3 power cables for the LDM and the 2 backup monitors
PDU	monitors	3 separate Protective Earth cables for the LDM and the 2 backup monitors
PDU	Suspension	1 Protective Earth cables for the suspension
C-FRT Cabinet	Monitors	4 RJ45 video cables for the LDM 1 RJ 45 video cables for each of the backup monitors
C-FRT Cabinet	Infrared receiver	1 cable with D-Sub 9 connector

**Table 2-4 Kit for the additional LDM suspension: all cable length 36 m (34.5 m usable length)**

From	To	Cable
PDU	monitor	1 power cable
PDU	monitor	1 separate Protective Earth cable
C-FRT Cabinet	Monitor	4 RJ45 video cables

**Table 2-5 Kit for 1 additional in-room 19" monitor: all cable length 24 m (22.5 m usable length)**

From	To	Cable
PDU	Monitor	1 power cable
PDU	Monitor	1 separate Protective Earth cable
C-FRT Cabinet	Monitor	1 RJ45 video cable

**2.1.2.2.5 Advantage Windows workstation (AW)**

The AW workstation option is composed of a workstation, 1 or 2 19" flat panel monitors in the Control Room.

Both AW screens can be displayed on the LDM.

An optional In-Room AW mouse interface kit can be installed. It is used to control the workstation through a wireless USB mouse in the Exam Room.

The wireless mouse is not provided in the kit and shall meet the following requirements:

- The shape of the mouse shall be suited for use under a sterile drape.
- It shall have 3 buttons with scroll: the left/right buttons, the up/down scrolling function and the middle scroll button.
- It shall use no specific driver (it shall use generic HID driver).
- The range of the wireless mouse shall be compatible with the distance between the working position and the location of the wireless receiver.

The wireless receiver shall be installed on the wall of the Exam Room, 1.50 m minimum and 5 m maximum from the table, at a suitable height for easy connection of the wireless dongle (1.10 m recommended).

If installed within 1.50 m of the table, the wireless receiver shall be installed inside a box that cannot be opened without a tool. This box shall be provided by the hospital.

The USB port for the wireless receiver can be installed flush on a plaster wall or on a technical sheath, or with a box for concrete walls (the box is provided in the kit):

Plaster wall



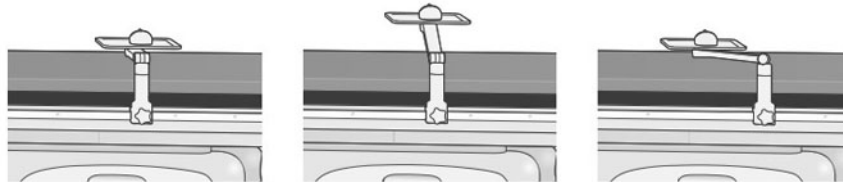
Technical sheath



Concrete wall



As an additional option, a Mouse Tray can be attached on the table side rails.



### 2.1.2.2.6 In-Room third party mouse interface kit installation

An optional In-Room third party mouse interface kit is used to control any third party device located in the control room through a wireless USB mouse in the Exam Room.

Refer to [2.1.2.2.5 Advantage Windows workstation \(AW\) on page 46](#) for the requirements on the wireless mouse and on the installation of the wireless receiver.

### 2.1.2.2.7 CENTRICITY CA1000

Refer to *Centricity Cardiology CA 1000 V2.0 Preinstallation Guide* in the OEMs of the System Service Manual.

### 2.1.2.2.8 MacLab

Refer to: Direction 5222007-1EN, *Mac-Lab/CardioLab/Centricity Cardiology INW Pre-Installation Manual*.

### 2.1.2.2.9 Injectors

The injectors certified for use with the system are:

Table 2-6

Certified Injectors	Omega Table	Innova <sup>IQ</sup> Table
MEDRAD Mark 7 (table mount version)	Yes	Yes
MEDRAD Mark 7 (pedestal version)	Yes	Yes
MEDRAD Mark 7 (ceiling mount version)	Yes	Yes
ACIST CVI (pedestal version)	Yes	Yes
ACIST CVI (table mount version)	Yes	No

**Table 2-6** (Table continued)

Certified Injectors	Omega Table	Innova <sup>IQ</sup> Table
Medtron Accutron HP model number 836	Yes	Yes
Medtron Accutron HP model number 832	Yes	Yes
Medtron Accutron HP model number 890	Yes	Yes
Medtron Accutron HP-D model number 833	Yes	Yes



**NOTE**

For MEDRAD Mark 7 table mount and ceiling mount, rack connected to C-FRT cabinet is located in technical room.

Table accessory rail load considerations:

Each table rail can withstand a load of 40 kg (88 lbs) at 150 mm (5.9") (60 N.m or 44.25 ft/lbs). Therefore, only a light load not exceeding 5 kg (11 lbs) at 100 mm (0.33 ft) can be mounted on the same table rail as the injector: for example IV pole with its accessories, pressure head, and so on. The front table rail is generally used for the User Interfaces, if needed an optional rail can be installed at table foot end of the Omega V table for other options.

The radiation protection and the injector shall never be installed on the same table rail.

**2.1.2.2.10 Third-Party on IGS Touch Panel**

This option gives the user the ability to remote **Third-Party controls on Allia IGS Touch Panel**.

The **Third-Party on IGS Touch Panel** option requires a **specific Ethernet network topology and cabling** to be configured on site by Service (at system first installation or after).

**2.1.2.3 Components location and characteristics**

**Table 2-7**

PRODUCT OR COMPONENT	Number of components in:			NET WEIGHT kg (lbs)	DIMENSIONS WIDTH x DEPTH x HEIGHT mm (in)	LOAD ON THE FLOOR kg/m2 (lb/ft2)
	Exam room	Control room	Technical room			
Gantry	1	-	-	(For System with 20 cm detector) 692 (1,526) (For System with 30 cm detector) 737 (1,625)	see <a href="#">Figure 2-11 Gantry - Dimensions and CoG - Side View on page 55</a> , <a href="#">Figure 2-12 Gantry - Dimensions and CoG - Top view on page 56</a> and <a href="#">Figure 2-13 Gantry - Dimensions and CoG - Front view on page 57</a>	2800 (574)

Table 2-7 (Table continued)

PRODUCT OR COMPONENT	Number of components in:			NET WEIGHT kg (lbs)	DIMENSIONS WIDTH x DEPTH x HEIGHT mm (in)	LOAD ON THE FLOOR kg/m2 (lb/ft2)
	Exam room	Control room	Technical room			
Omega Table	1	-	-	741.6 (1,635) See NOTE (1)	see Figure 2-14 Omega IV Compact Patient Table - Dimensions and CoG on page 58 and Figure 2-17 Omega V Long Patient Table - Dimensions and CoG on page 61	3065 (628)
Innova <sup>IQ</sup> Table		--	-	1017 (2,242) See NOTE (1)	see Figure 2-20 Innova <sup>IQ</sup> Table - Dimensions on page 64	2260 (463)
Footswitch	1	-	-	Not applicable	Not applicable	Not applicable
Control Panel without clamping	1	-	-	3.5 (6.6)	320 (12.6) x 190 (7.5)	Not applicable
Control Panel with clamping		-	-	4 (8.8)		Not applicable
Touch Panel without clamping	1	-	-	2.5 (4.4)	350 (13.8) x 220 (8.7) x 110 (4.3)	Not applicable
Touch Panel with clamping		-	-	3 (6)		Not applicable
Touch Panel with arm		-	-	4.5 (10)	Not applicable	Not applicable
IGS Control Center (option for Innova <sup>IQ</sup> Table)	1	-	-	29 (63.9)	see Figure 2-29 IGS Control Center - Dimensions on page 72	Not applicable
VCIM	-	1	-	0.95 (2.09)	450 (17.7) x 150 (5.9) x 50 (2)	Not applicable
DL Keypad	-	1	-	1.4 (3)	see Figure 2-31 DL Keypad - Dimensions on page 73	Not applicable
DL Monitor	-	1	-	5.6 (12.3)	Not applicable	Not applicable

**Table 2-7** (Table continued)

PRODUCT OR COMPONENT	Number of components in:			NET WEIGHT kg (lbs)	DIMENSIONS WIDTH x DEPTH x HEIGHT mm (in)	LOAD ON THE FLOOR kg/m2 (lb/ft2)
	Exam room	Control room	Technical room			
C-FRT Cabinet	-	-	1	523 (1,153) (with LMM)	see Figure 2-32 C-FRT Cabinet - Dimensions and CoG on page 74	Configuration A: 540 (110.6) (with L=1.366 m (4.5 ft), W=0.709 m (2.3 ft)) Configuration B: 1114 (228.2) (with L=1.025 m (3.4 ft), W=0.458 (1.5 ft)) See NOTE (2)
PDU V2 / System Interface cabinet	-	-	1	280.5 (617)	see Figure 2-35 PDU V2 Cabinet / System Interface Cabinet - Dimensions and CoG - Side View / Front View / Side View on page 76	Configuration A: 701 (143.6) (with L=1 m (3.3 ft), W=0.40 m (1.31 ft)) Configuration B: 1078 (220.8) (with L=0.79 m (2.6 ft), W=.0.33 m (1.1 ft)) See NOTE (2)
X-PDU / System Interface cabinet	-	-		245 (540)	see Figure 2-38 X-PDU Cabinet / System Interface Cabinet - Dimensions and CoG - Front View / Left Side View on page 78	Configuration A: 628 (128.7) (with L=0.97 m (3.2 ft), W=0.40 m (1.3 ft)) Configuration B: 917 (187.9) (with L=0.76 m (2.5 ft), W=0.35 m (1.15 ft)) See NOTE (2)
8 kVA Gen1 UPS	-	-	1	84 (185)	see Figure 2-41 8 kVA Gen1 UPS - Dimensions and CoG on page 80	Not applicable
8 kVA Gen2 UPS	-	-		78.8 (174)	see Figure 2-42 Alternate 8 kVA Gen2 UPS - Dimensions and CoG on page 81	Not applicable

Table 2-7 (Table continued)

PRODUCT OR COMPONENT	Number of components in:			NET WEIGHT kg (lbs)	DIMENSIONS WIDTH x DEPTH x HEIGHT mm (in)	LOAD ON THE FLOOR kg/m2 (lb/ft2)
	Exam room	Control room	Technical room			
Fluoro UPS (11 kVA)	-	-		78.8 (174)	see Figure 2-43 Fluoro UPS 11 kVA - Dimensions and CoG on page 82	Not applicable
20 kVA Fluoro UPS UL	-	-		530 (1,169)	see Figure 2-44 20 kVA Fluoro UPS UL - Dimensions and CoG on page 83	975 (200)
20 kVA Fluoro UPS CE	-	-		280 (617)	see Figure 2-45 20 kVA Fluoro UPS CE - Dimensions and CoG on page 85	1114 (228)
Tube Cooling Unit	-	-	1	Without coolant: 53 (116.8) With coolant: 65.5 (144.4)	see Figure 2-46 X-Ray Tube Cooling Unit - Dimensions and CoG on page 86	Without coolant: 716 (146.6) With coolant: 885 (181.3)
Detector Conditioner	-	-	1	14.6 (32)	see Figure 2-48 Detector Conditioner - Dimensions and CoG on page 88	Not applicable
<b>(For Omega Table)</b> I-Box	-	-	1	3 (6.6)	see Figure 2-49 I-Box - Dimensions on page 89	Not applicable
OPTIONS						
Monitors						
19" System Monitor without stand	Up to 4	-	-	4.3 (9.5)	405 (15.9) x 61 (2.4) x 334 (13.1)	Not applicable
AW Monitor	Up to 2	-	-	4.3 (9.5)	405 (15.9) x 61 (2.4) x 334 (13.1)	Not applicable
19" System Monitor with stand	-	Up to 3	-	6.1 (13.4)	405 (15.9) x 61 (2.4) x 334 (13.1)	Not applicable

Table 2-7 (Table continued)

PRODUCT OR COMPONENT	Number of components in:			NET WEIGHT kg (lbs)	DIMENSIONS WIDTH x DEPTH x HEIGHT mm (in)	LOAD ON THE FLOOR kg/m2 (lb/ft2)
	Exam room	Control room	Technical room			
Large Display Monitor (without integrated protective screen)	Up to 2		-	38 (83.8)	1246 (49) x 136 (5.4) x 719 (28.3)	Not applicable
Protective screen option for Large Display Monitor			-	12 (26.5)	1251 (49.3) x 55 (2.2) x 725 (28.6)	Not applicable
Large Display Monitor (with integrated protective screen)			-	47.5 (104.7)	1246 (49) x 136 (5.4) x 719 (28.3)	Not applicable
19" Backup Monitor for Large Display	2	-	-	4.3 (9.5)	405 (15.9) x 61 (2.4) x 334 (13.1)	Not applicable
User Interfaces and accessories						
Additional Control Panel	<b>(For Omega Table)</b> Up to 2: 1 in Exam Room and 1 in Control Room <b>(For Innova IQ Table)</b> Up to 2: 1 in Exam Room and 1 in Control Room <b>or</b> 2 in Exam Room (Table + IGS Control Center option)		-	Refer to net weight above	Refer to dimensions above	Not applicable
Additional Touch Panel	1	-	-	Refer to net weight above	Refer to dimensions above	Not applicable
Bolus Handle	1	-	-	Not applicable	Not applicable	Not applicable
<b>(For Innova IQ Table)</b> I-Box	-	-	1	Refer to net weight above	Refer to dimensions above	Not applicable
In-room AW mouse interface kit	1		-	Not applicable	Not applicable	Not applicable
Table Side Cart	1	-	-	Not applicable	Not applicable	Not applicable
IR Receiver Module	1	-	-	0.3 (0.7)	112 (4.4) x 31 (1.2) x 76 (3)	Not applicable
Diamantor Display Module	1	-	-	1 (2.2)	210 (8.3) x 146 (5.7) x 58 (2.3)	Not applicable
ECG Acquisition Device Module						

Table 2-7 (Table continued)

PRODUCT OR COMPONENT	Number of components in:			NET WEIGHT kg (lbs)	DIMENSIONS WIDTH x DEPTH x HEIGHT mm (in)	LOAD ON THE FLOOR kg/m2 (lb/ft2)
	Exam room	Control room	Technical room			
Physio box	1	-	-	Not applicable	see Figure 2-50 ECG Acquisition Device Module - Physio Box dimensions (Optional) on page 89	Not applicable
Suspension						
Precabled LD suspension with rails (self weight without monitor and accessories given)	1	-	-	215 (474)	see Figure 2-52 Large Display Suspension with rails - Dimensions (Optional) on page 91	Not applicable
Precabled LD Mavig suspension with fixed point dual arm	1	-	-	190 (419)	see Figure 2-54 MAVIG suspension with fixed point dual arm for Large Display Monitor - Dimensions (Optional) on page 93	Not applicable
Substructure for Dual Arm suspension (for LD Mavig suspension with fixed point dual arm)	1	-	-	58 (128)	see Figure 2-51 Ceiling Plate of Substructure for Dual Arm suspension - Dimensions on page 90	Not applicable
Utility						
V-Point	3	-	-	Not applicable	see Figure 2-56 V-Point Box - Dimensions (Optional) on page 95	Not applicable

**NOTE**

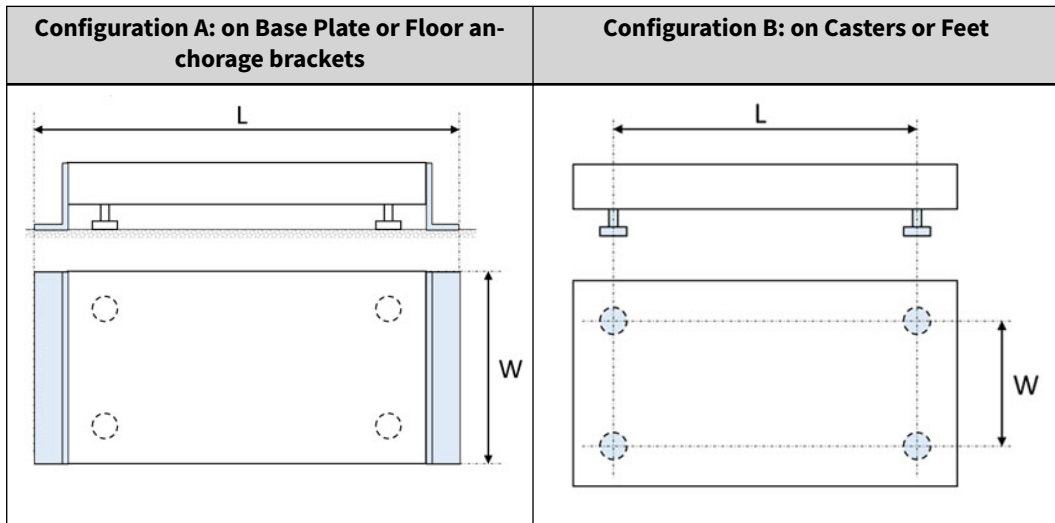
**(1):** Including patient weight. Patient weight considered is:

- 204 kg (450 lbs) for Omega Table,
- 250 kg (551 lbs) for Innova<sup>IQ</sup> Table.



**NOTE**  
**(2):** Configuration for Load on the floor calculation

**Table 2-8**



**WARNING**



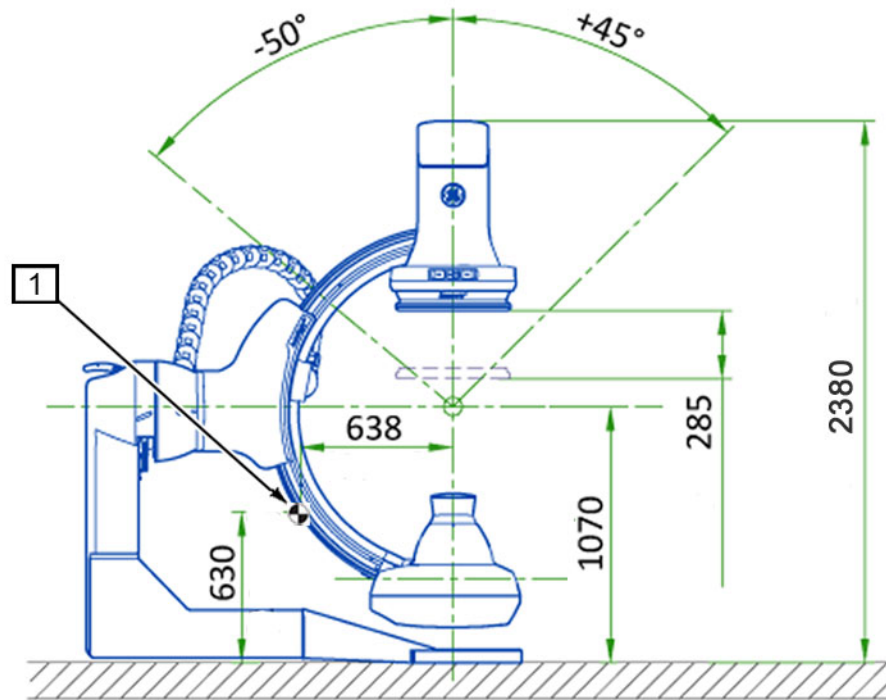
THE COMPONENTS IDENTIFIED AS TO BE INSTALLED IN THE TECHNICAL ROOM ARE NOT CERTIFIED FOR USE OUTSIDE OF THIS AREA. IT IS MANDATORY TO INSTALL THEM IN THE TECHNICAL ROOM.

## 2.1.3 Dimension Drawings

Refer to this section for:

- the dimensional drawings of the system components,
- the location of the components center of gravity,
- Positioner/table relative position drawings.

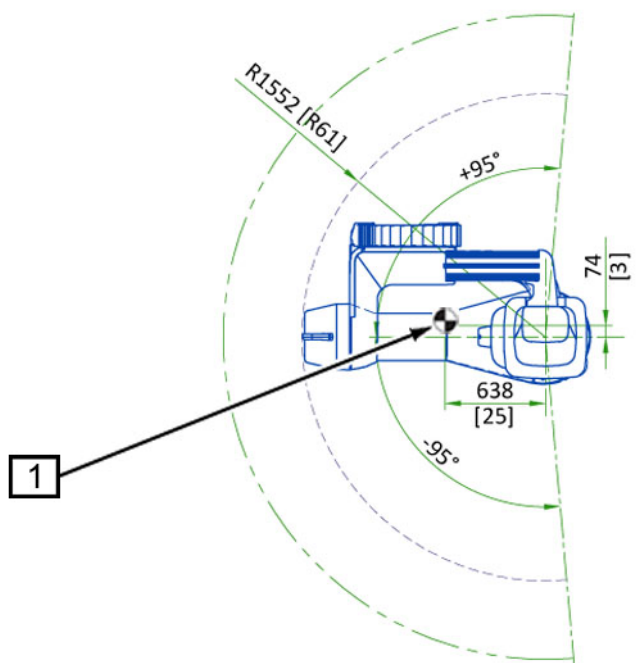
**Figure 2-11 Gantry - Dimensions and CoG - Side View**



Dimensions in mm

Item	Description
[1]	Center of Gravity

**Figure 2-12 Gantry - Dimensions and CoG - Top view**



Dimensions in mm (in)

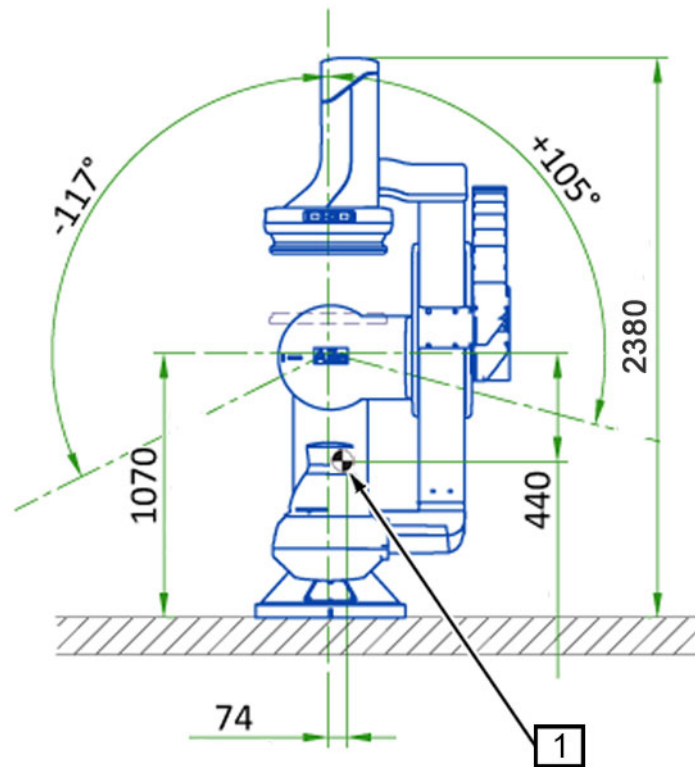


**NOTE**

The LC gantry side movement of +95 to -95 is for motorized movement. With manual movement, a range of +100 to -100 is obtained.

Item	Description
[1]	Center of Gravity

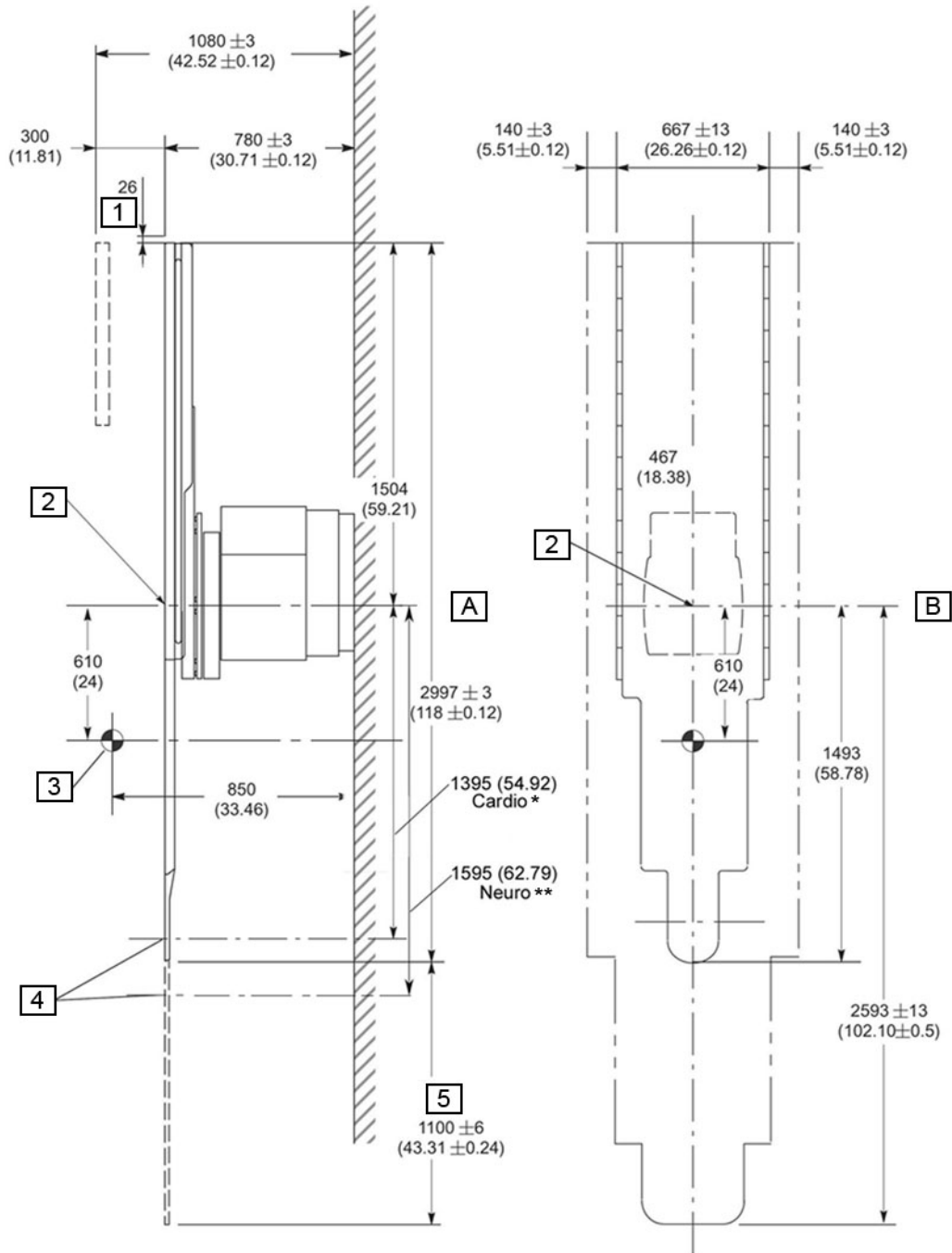
**Figure 2-13 Gantry - Dimensions and CoG - Front view**



Dimensions in mm

Item	Description
[1]	Center of Gravity

Figure 2-14 Omega IV Compact Patient Table - Dimensions and CoG

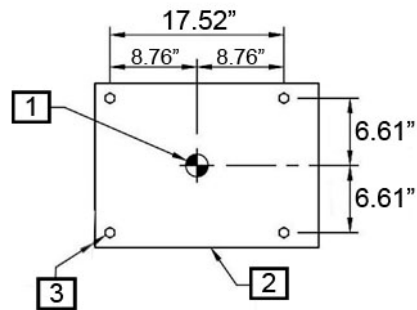


Dimensions in mm (in)

Item	Description
[A]	Side view
[B]	Top view
[1]	Table top at maximum height and patient weight = 204 kg (450 lbs)
[2]	Omega IV compact patient table pivot point
[3]	Center of Gravity with Table top at maximum height and patient weight = 204 kg (450 lbs)
[4]	LCA H1C positioner isocenter
[5]	Table top travel

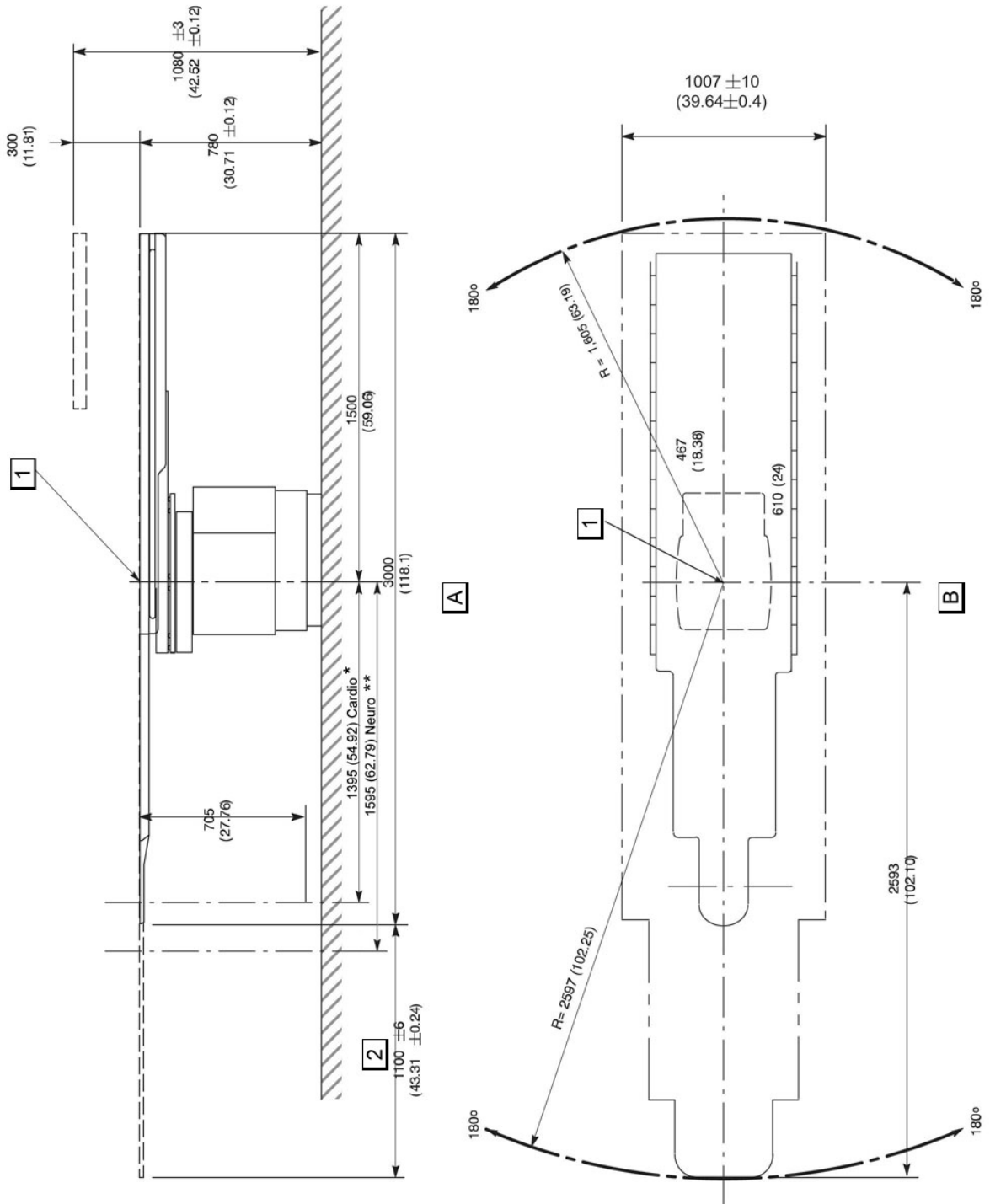
Item	Description
*	Cardio
**	Neuro

**Figure 2-15 Omega IV Compact Patient Table - Plan at Base**



Item	Description
[1]	Center of Gravity
[2]	Table Base
[3]	Hole diameter: 29 mm (1.14")

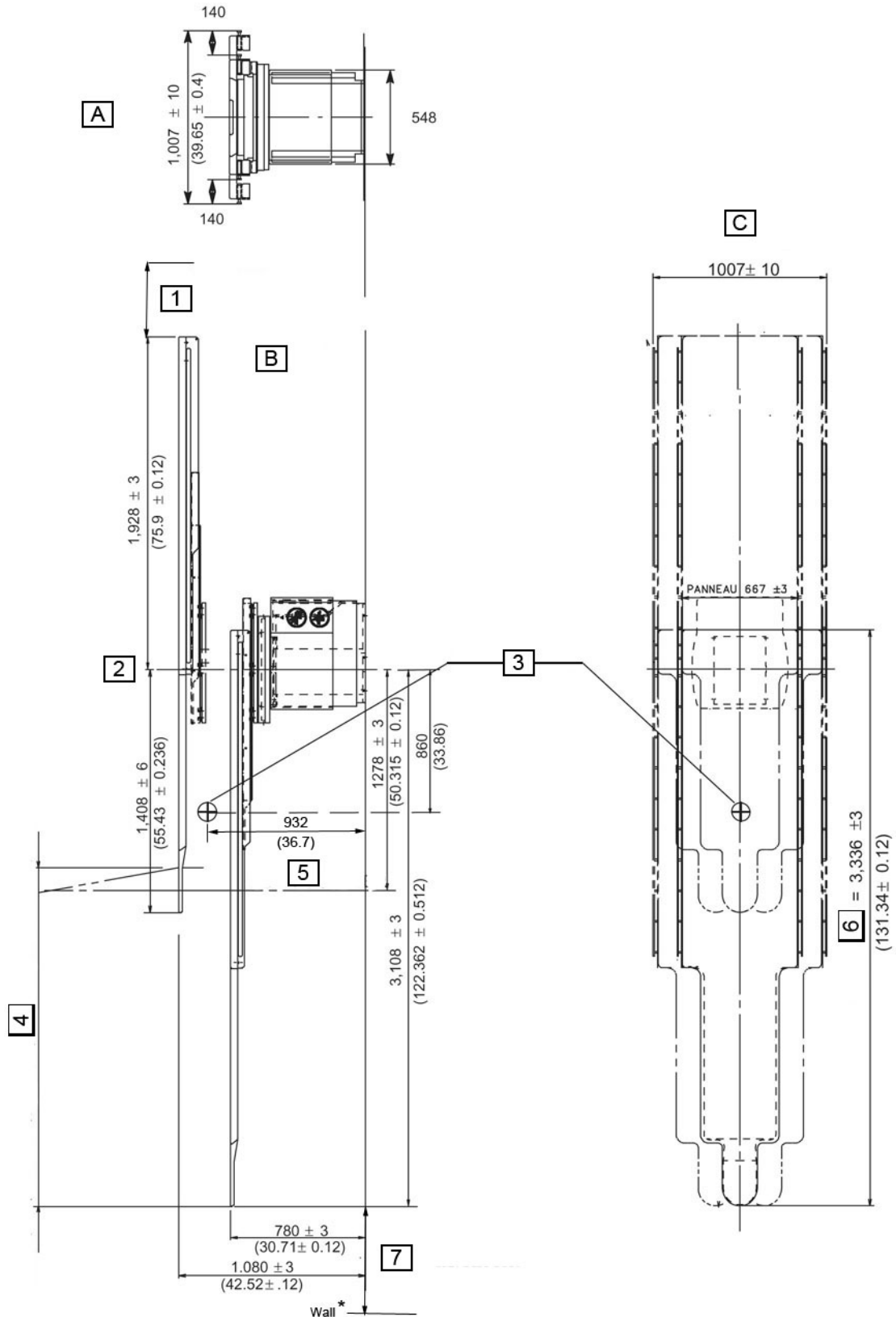
Figure 2-16 Omega IV Compact Patient Table Interference Regions (Allia IGS 520)



Dimensions in mm (in)

Item	Description
[A]	Side view
[B]	Top view
[1]	Omega IV compact patient table pivot point
[2]	Table top travel
*	Cardio
**	Neuro

Figure 2-17 Omega V Long Patient Table - Dimensions and CoG

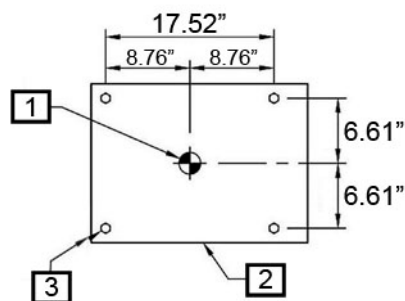


Dimensions in mm (in)

Item	Description
[A]	Front view (foot end)
[B]	Side view

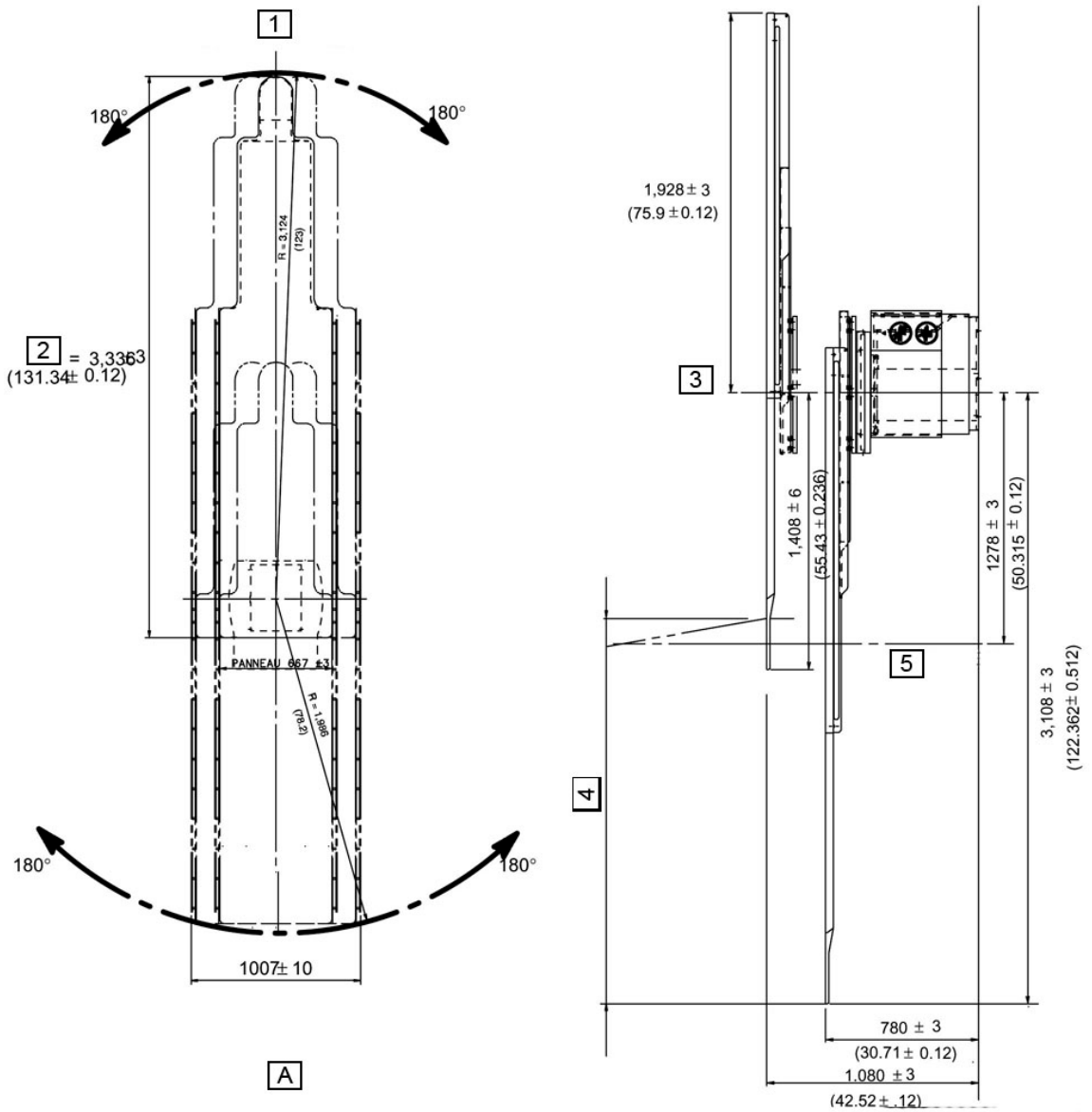
Item	Description
[C]	Top view
[1]	500 mm (19.5 in) minimum clearance between table end and nearest object
[2]	Table pivot
[3]	Center of Gravity with Table top at maximum height and patient weight = 204 kg (450 lbs)
[4]	Patient coverage = 1980 (77.95) between mechanical stops
[5]	LCA isocenter
[6]	Table top
[7]	Caution: a distance of 700 mm (27.6 in) is mandatory if the head extender is used
*	Wall

Figure 2-18 Omega V Long Patient Table - Plan at Base



Item	Description
[1]	Center of Gravity
[2]	Table Base
[3]	Hole diameter: 29 mm (1.14")

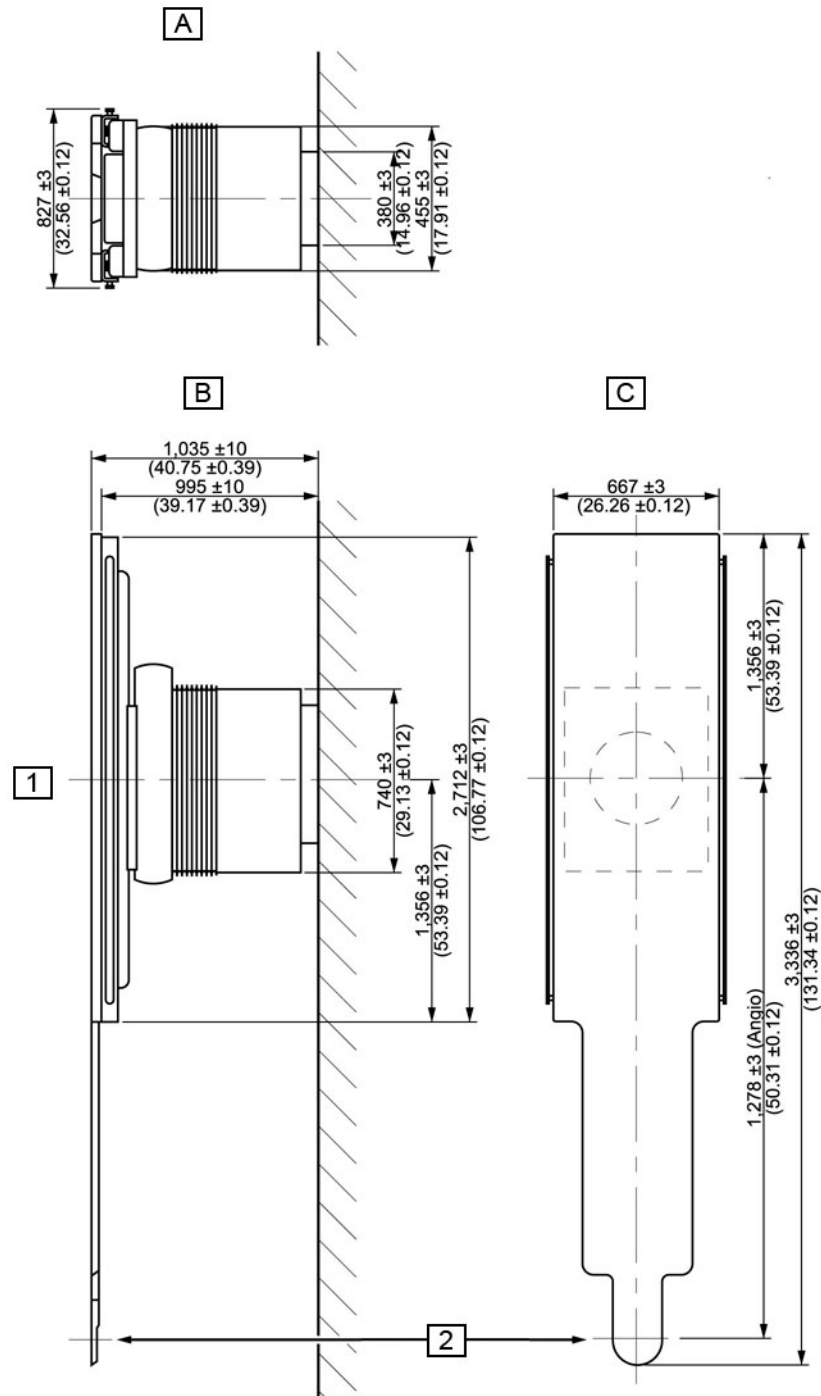
Figure 2-19 Omega V Long Patient Table Interference Regions



Dimensions in mm (in)

Item	Description
[A]	Top view
[1]	Table rotation
[2]	Table top
[3]	Table pivot
[4]	Patient coverage = 1980 (77.95) between mechanical stops
[5]	LCA isocenter

Figure 2-20 Innova<sup>IQ</sup> Table - Dimensions



Dimensions in mm (in)



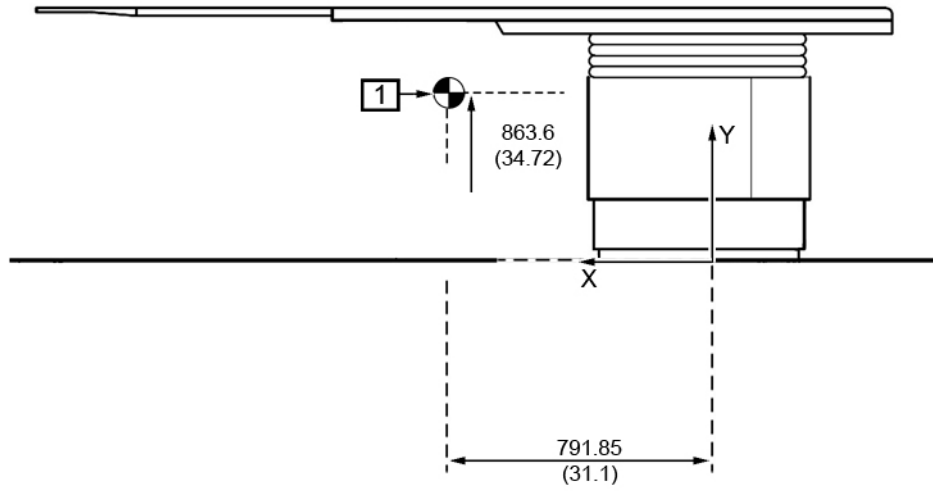
**NOTE**

The table dimensions are correct for the position (longi=0, lat=0, lift=0, tilt=0, rot=0)

Item	Description
[A]	Front view (head end)
[B]	Side view
[C]	Top view
[1]	Table pivot

Item	Description
[2]	LCA isocenter

Figure 2-21 Innova<sup>IQ</sup> Table - CoG

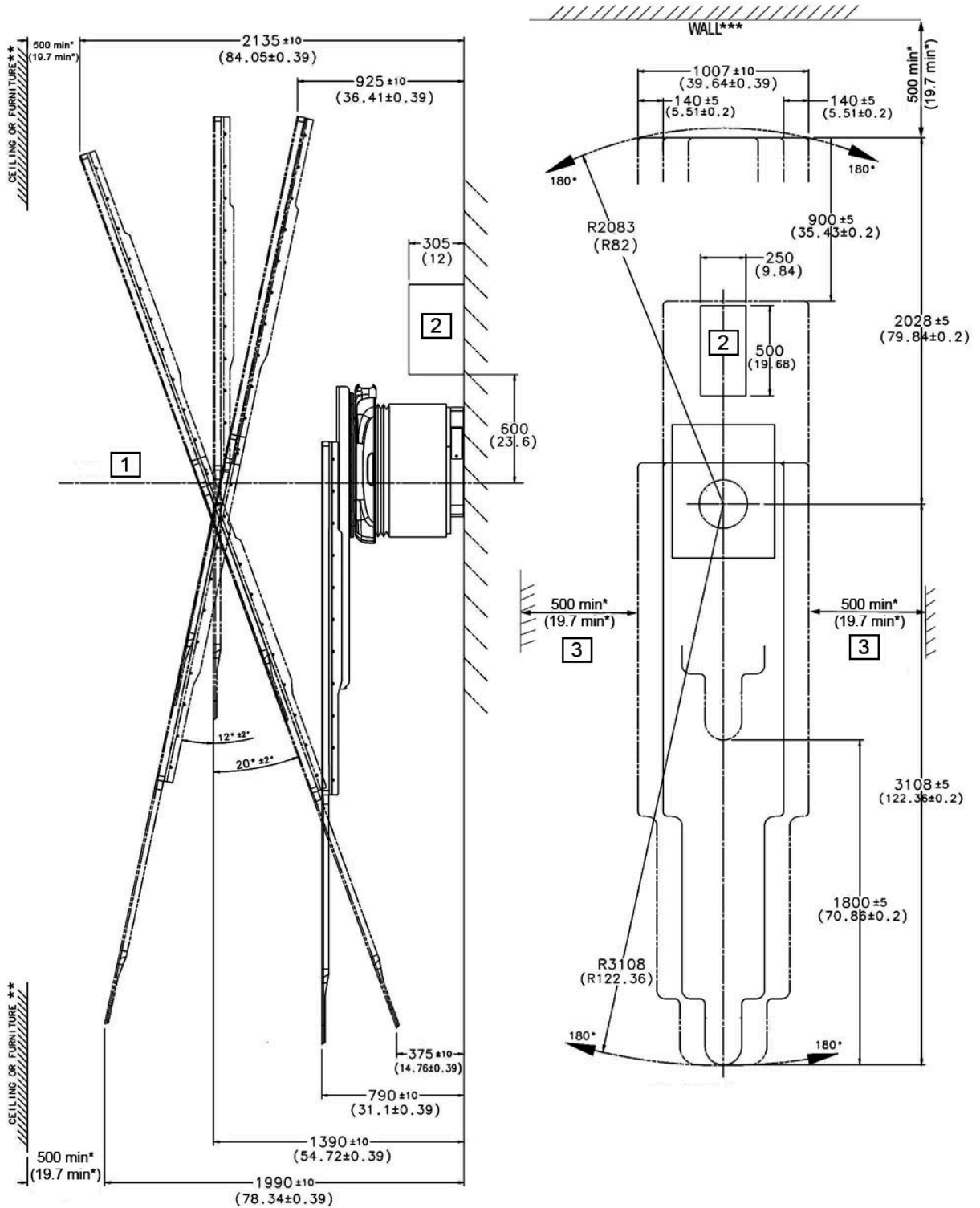


Dimensions in mm (in)

Table 2-9

Item	Description
[1]	Center of Gravity

Figure 2-22 Innova<sup>IQ</sup> Table Interference Regions



Dimensions in mm (in)

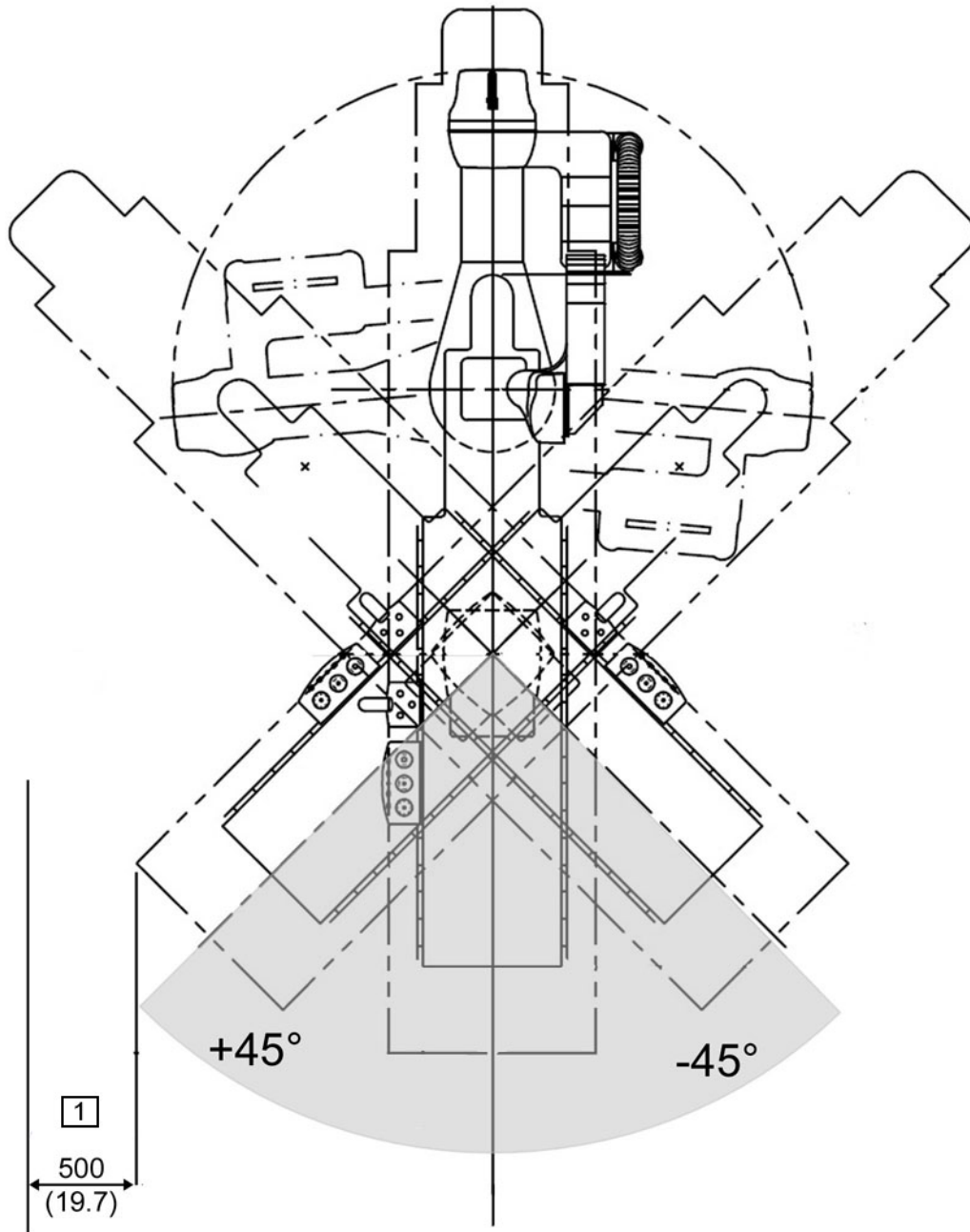
Item	Description
[1]	Table pivot
[2]	Medical gas box <sup>(1)</sup>
[3]	Minimum clearance to wall at max rotation
*	Minimum
**	Ceiling or furniture

Item	Description
***	Wall

**NOTICE**

(1) The medical gas box under the table is not recommended for the surgical configuration.

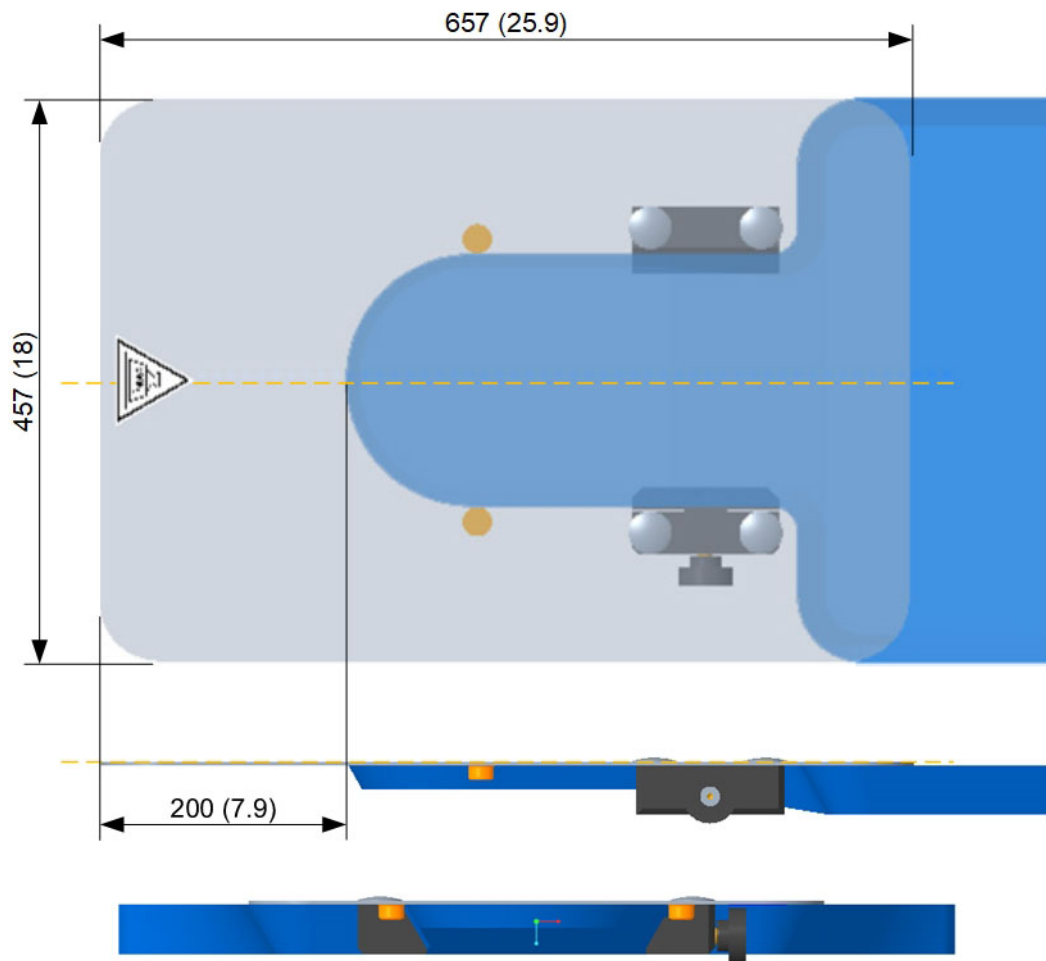
**Figure 2-23 Patient Table side clearance (CPR access)**



Dimensions in mm (in)

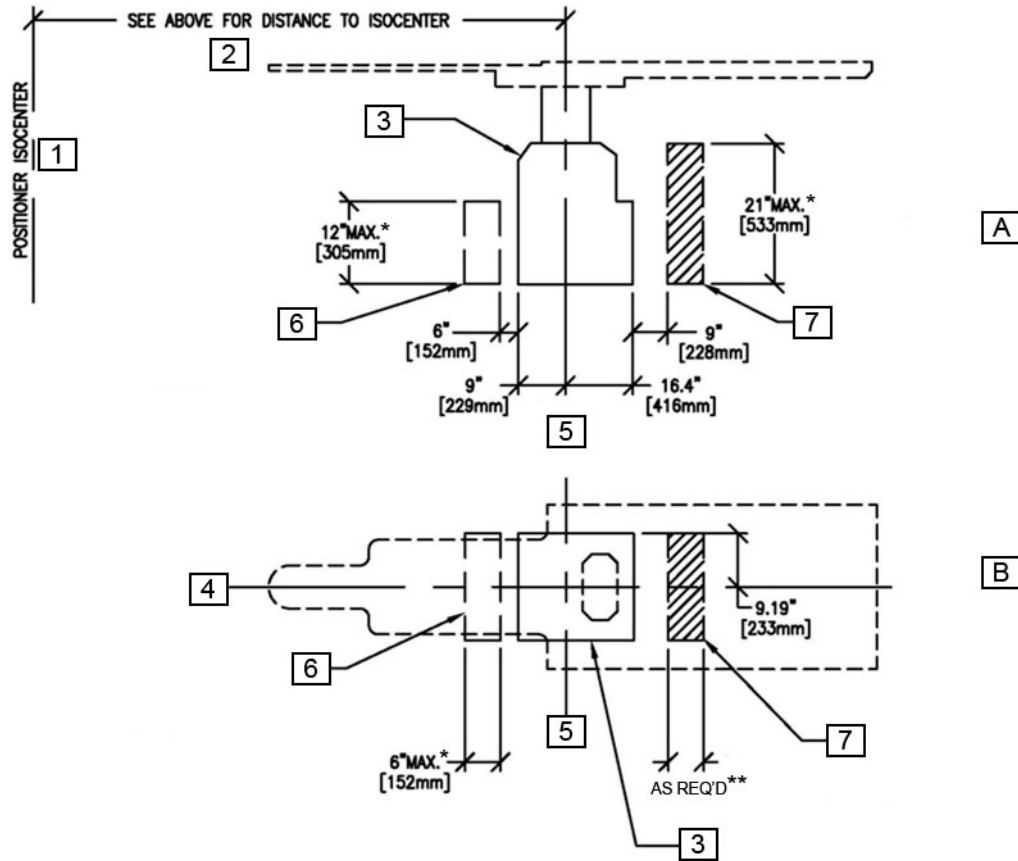
Item	Description
[1]	Clearance

Figure 2-24 Table Head Extender - Dimensions - Top view / Side view / Front view



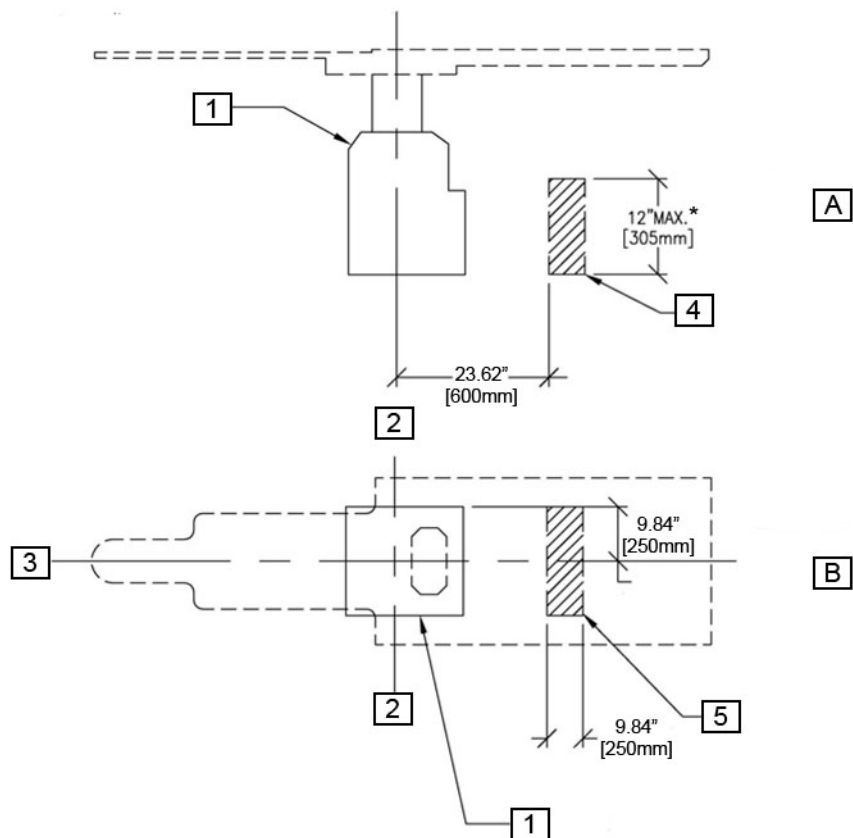
Dimensions in mm (in)

Figure 2-25 Gas box outlets Omega Table



Item	Description
[A]	Side view
[B]	Plan view
[1]	Positioner isocenter
[2]	See above for distance to isocenter
[3]	Table base
[4]	Table CL
[5]	Table pivot CL
[6]	Alternate area for physio. or med. gases, 12" (305 mm) height restriction in this area
[7]	Recommended area for physio. or med. gases, 21" (533 mm) height restriction in this area
*	Maximum
**	As required

Figure 2-26 Gas box outlets InnovalQ Table

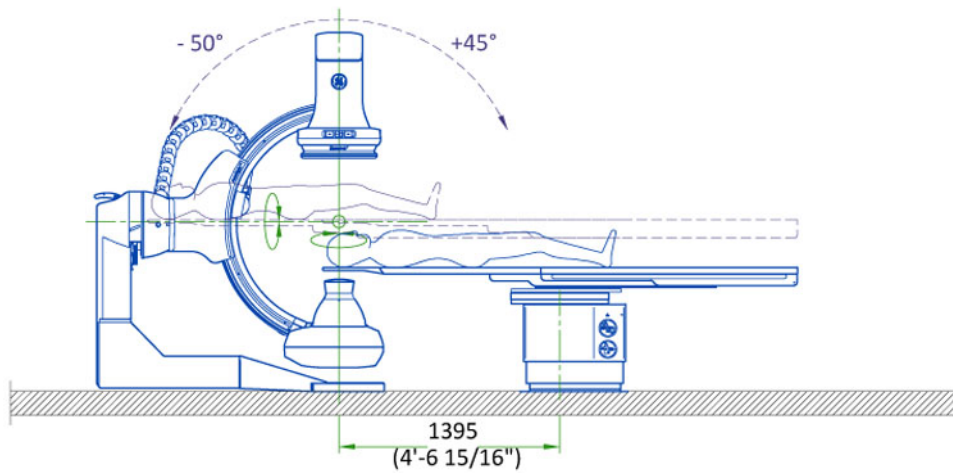


Item	Description
[A]	Side view
[B]	Plan view
[1]	Table base
[2]	Table pivot CL
[3]	Table CL
[4]	Area for physio. or med. gases, 12" (305 mm) height restriction in this area <sup>(1)</sup>
[5]	Area for physio. or med. gases <sup>(1)</sup>
*	Maximum

**NOTICE**

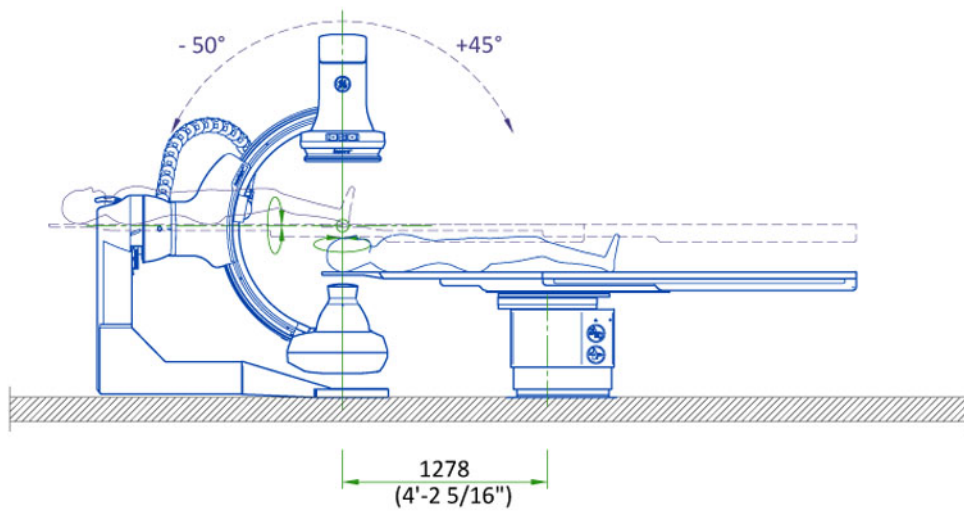
(1) The utility box under the table is not recommended for the surgical configuration.

**Figure 2-27 Gantry and Omega IV Compact Patient Table Relative Positions (Allia IGS 520) - Side View**



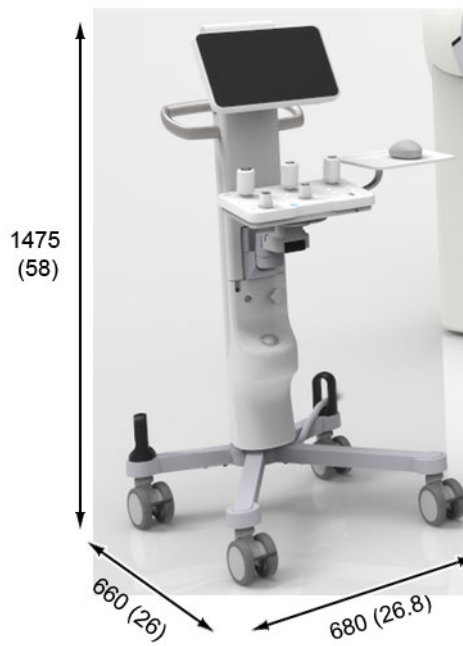
Dimensions in mm unless otherwise specified

**Figure 2-28 Gantry and Omega V Long Patient Table Relative Positions - Side View**



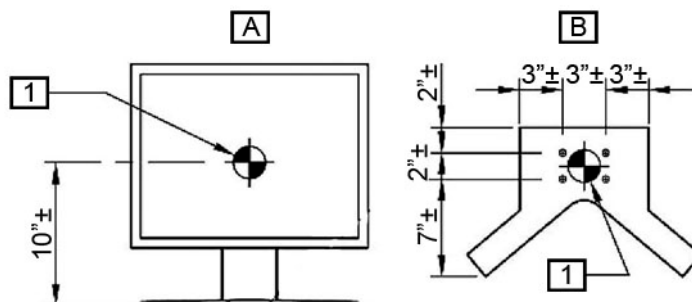
Dimensions in mm unless otherwise specified

**Figure 2-29 IGS Control Center - Dimensions**



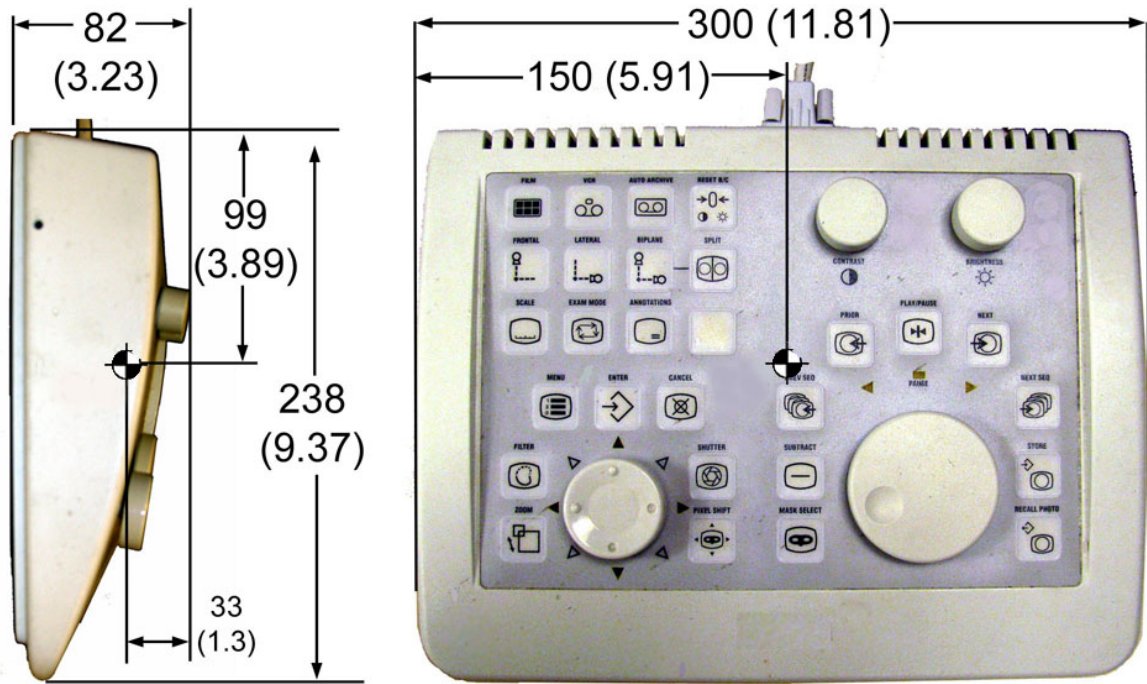
Dimensions in mm (in)

**Figure 2-30 19" Desk Mounted Monitor - CoG**



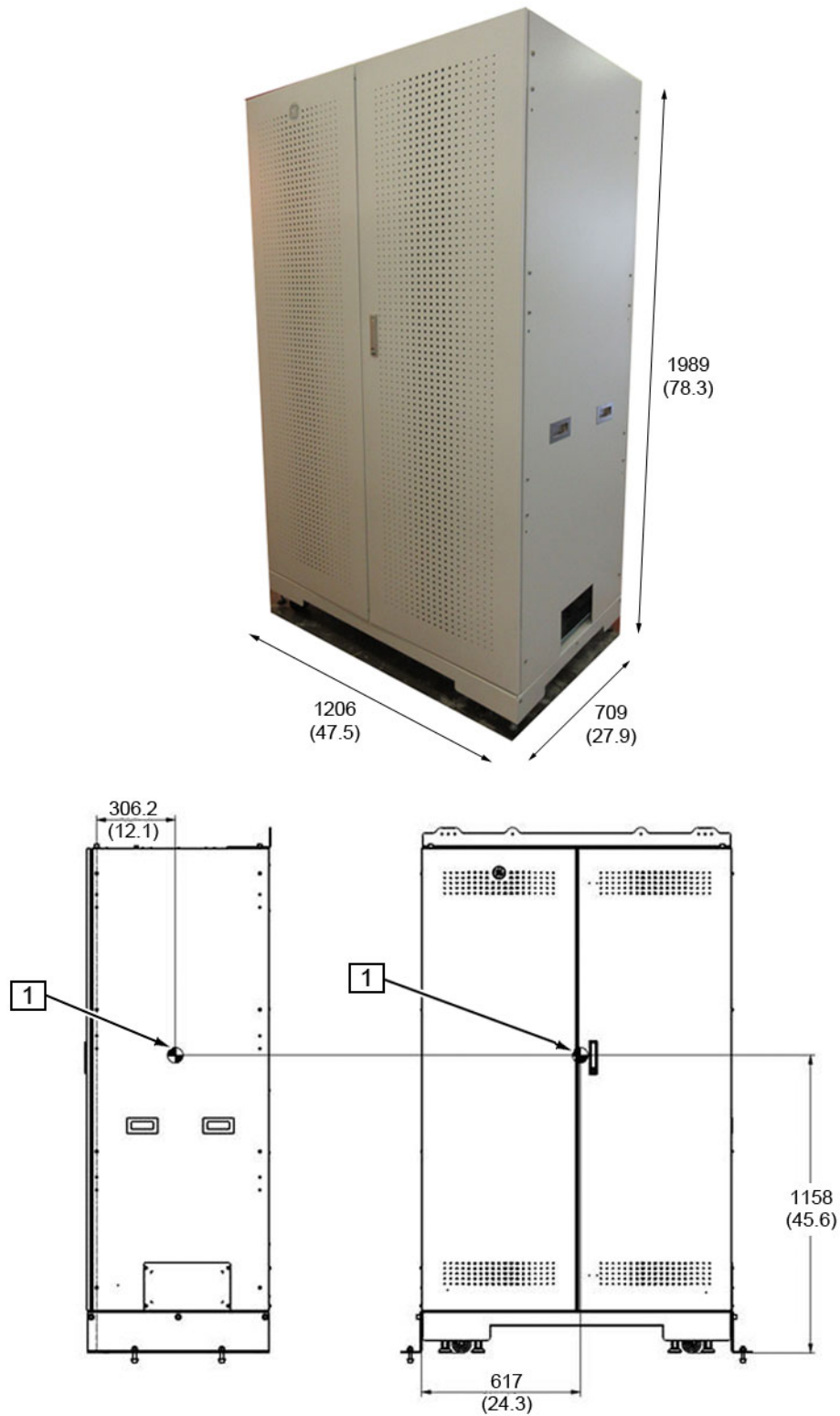
Item	Description
[A]	Front Elevation
[B]	Plan at Base
[1]	Center of Gravity

Figure 2-31 DL Keypad - Dimensions



Dimensions in mm (in)

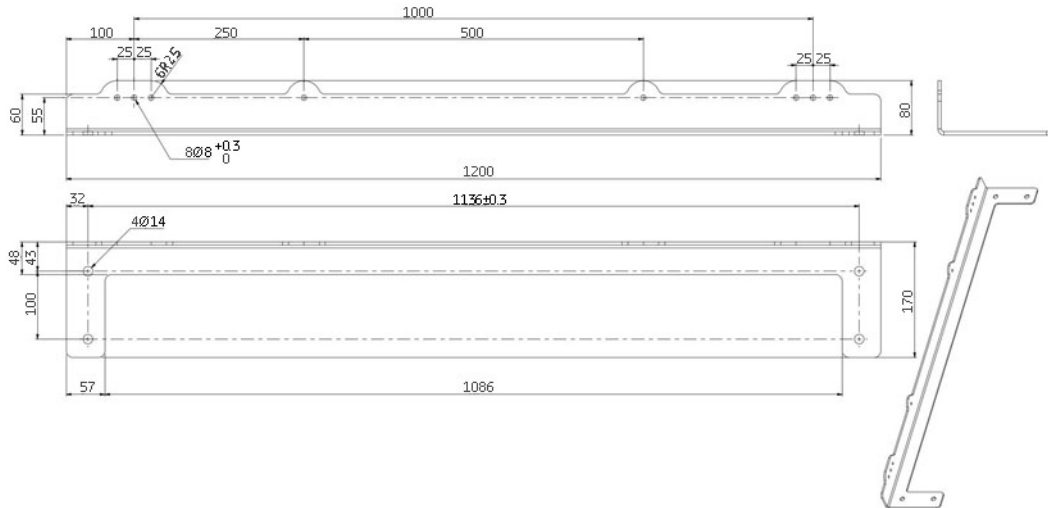
**Figure 2-32 C-FRT Cabinet - Dimensions and CoG**



Dimensions in mm (in)

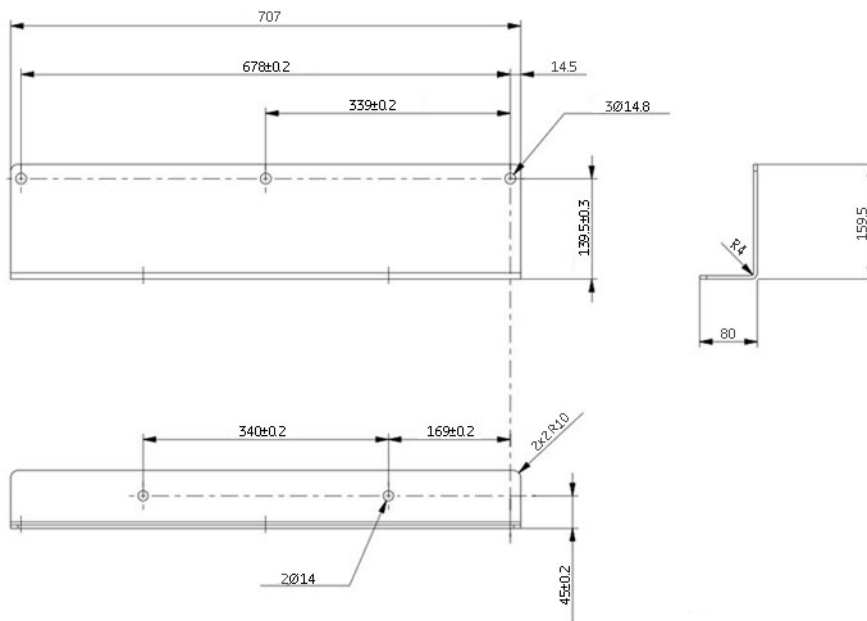
Item	Description
[1]	Center of Gravity

Figure 2-33 C-FRT Cabinet - Top Seismic Anchor (Sheet metal S355MC. 1.0976, thickness 5 mm)



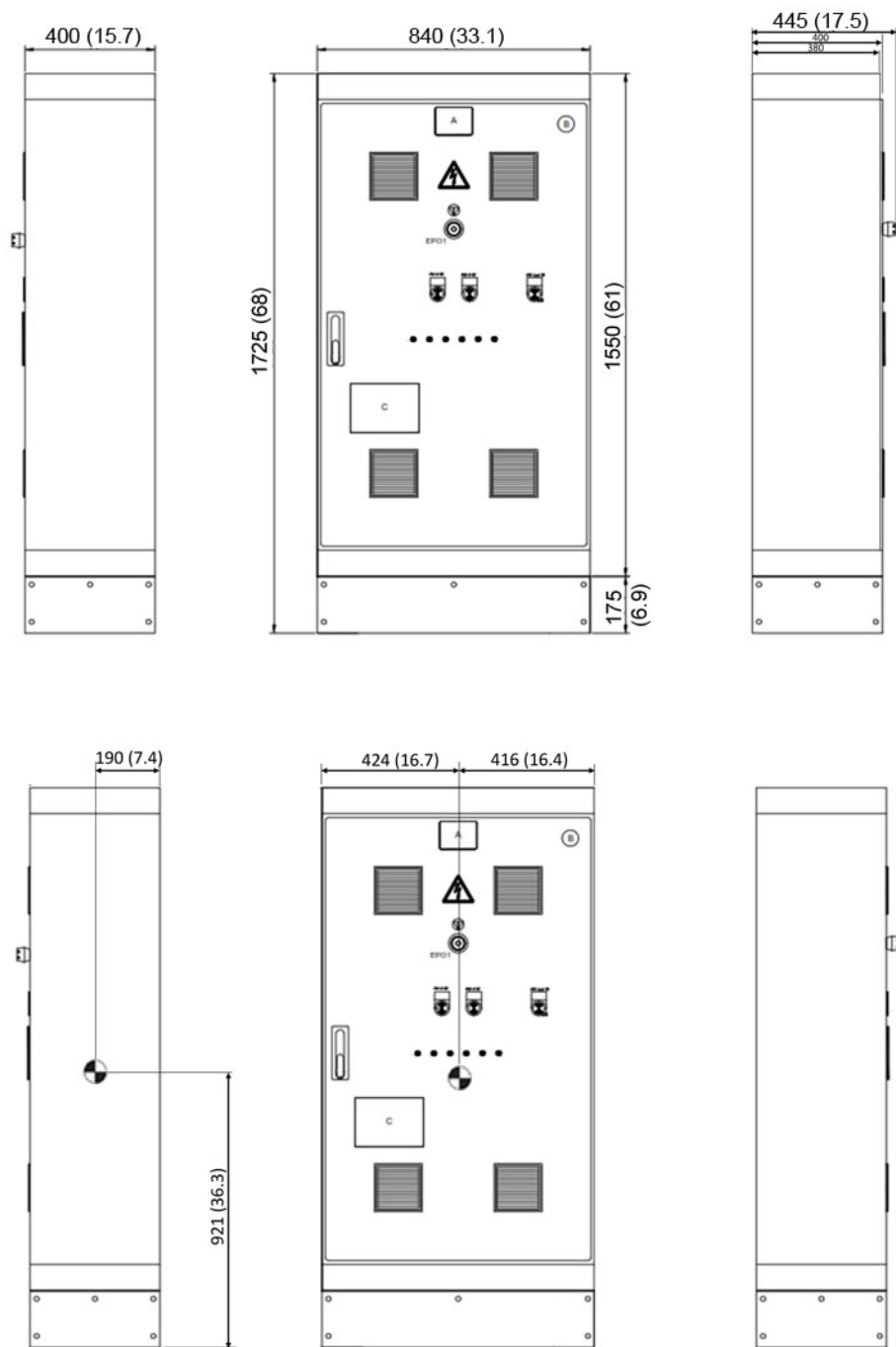
Dimensions in mm

Figure 2-34 C-FRT Cabinet - Anchor Bracket (Sheet metal S355MC. 1.0976, thickness 5 mm)



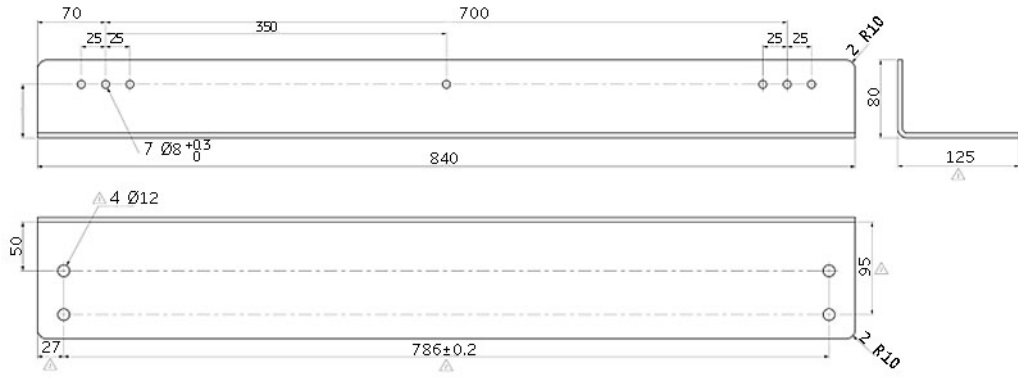
Dimensions in mm

**Figure 2-35 PDU V2 Cabinet / System Interface Cabinet - Dimensions and CoG - Side View / Front View / Side View**



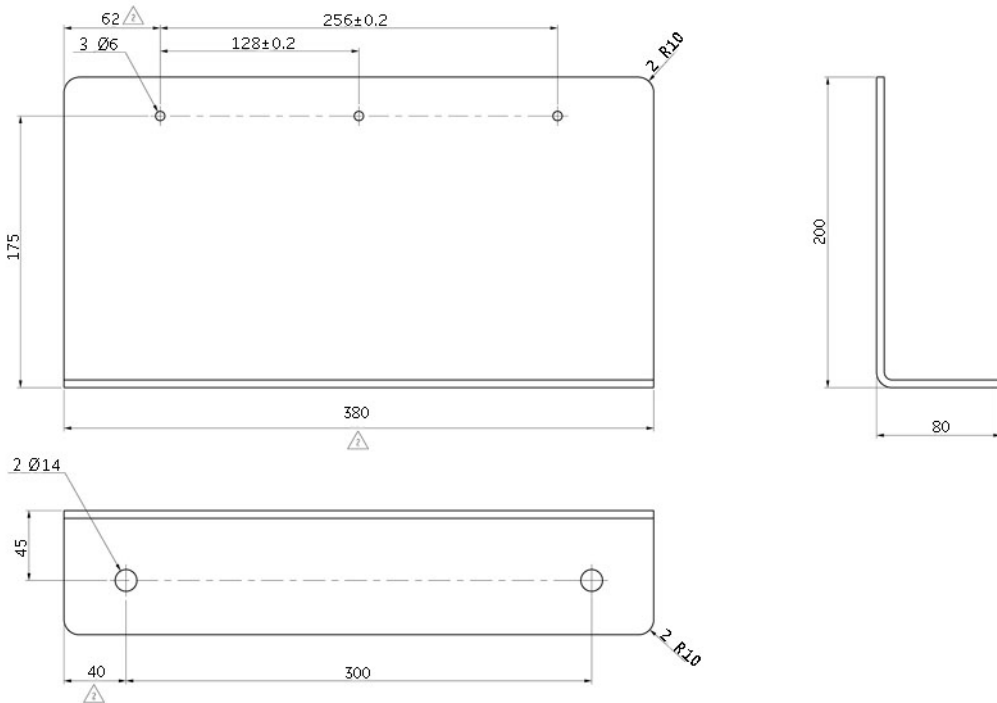
Dimensions in mm (in)

**Figure 2-36 PDU V2 Cabinet - Top bracket (Sheet metal S355MC. 1.0976, thickness 5 mm)**



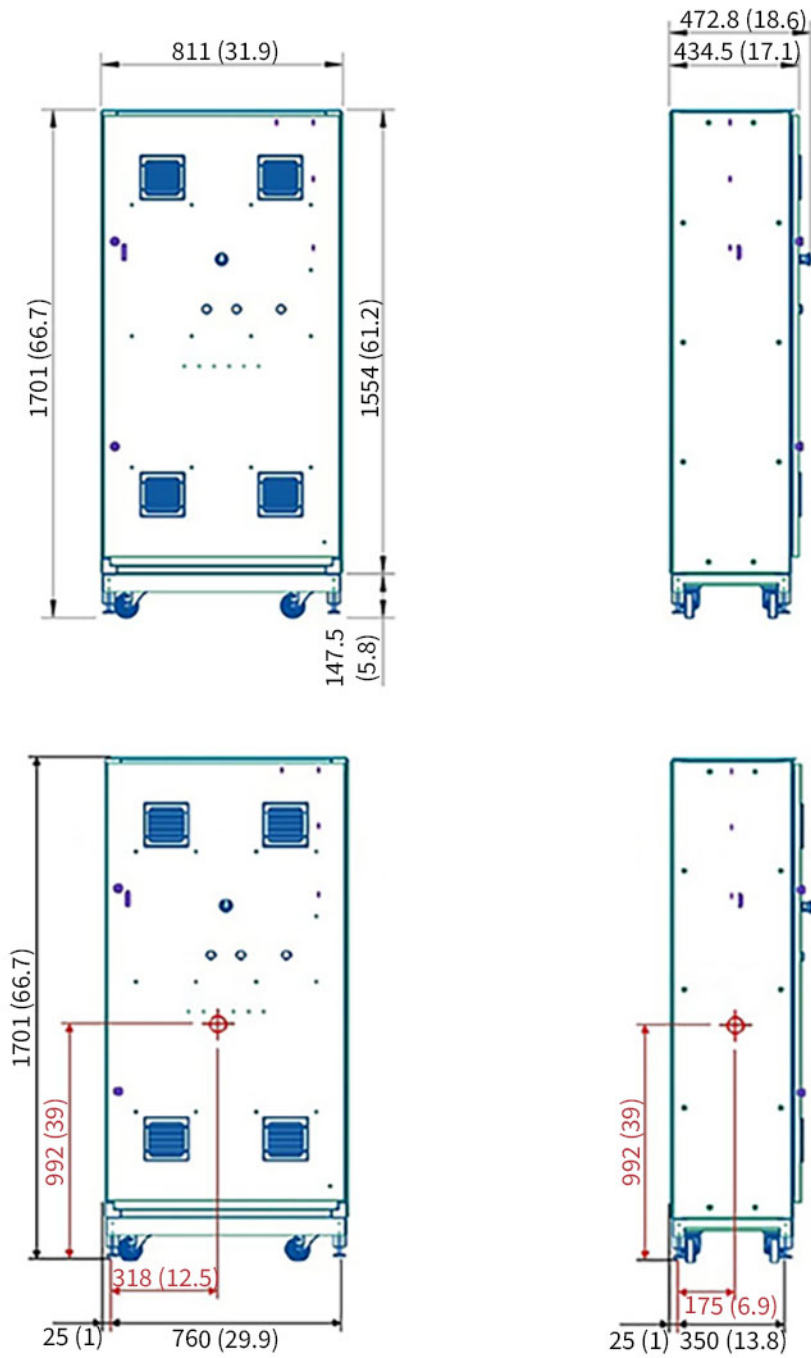
Dimensions in mm

**Figure 2-37 PDU V2 Cabinet - Side bracket (Sheet metal S355MC. 1.0976, thickness 5 mm)**



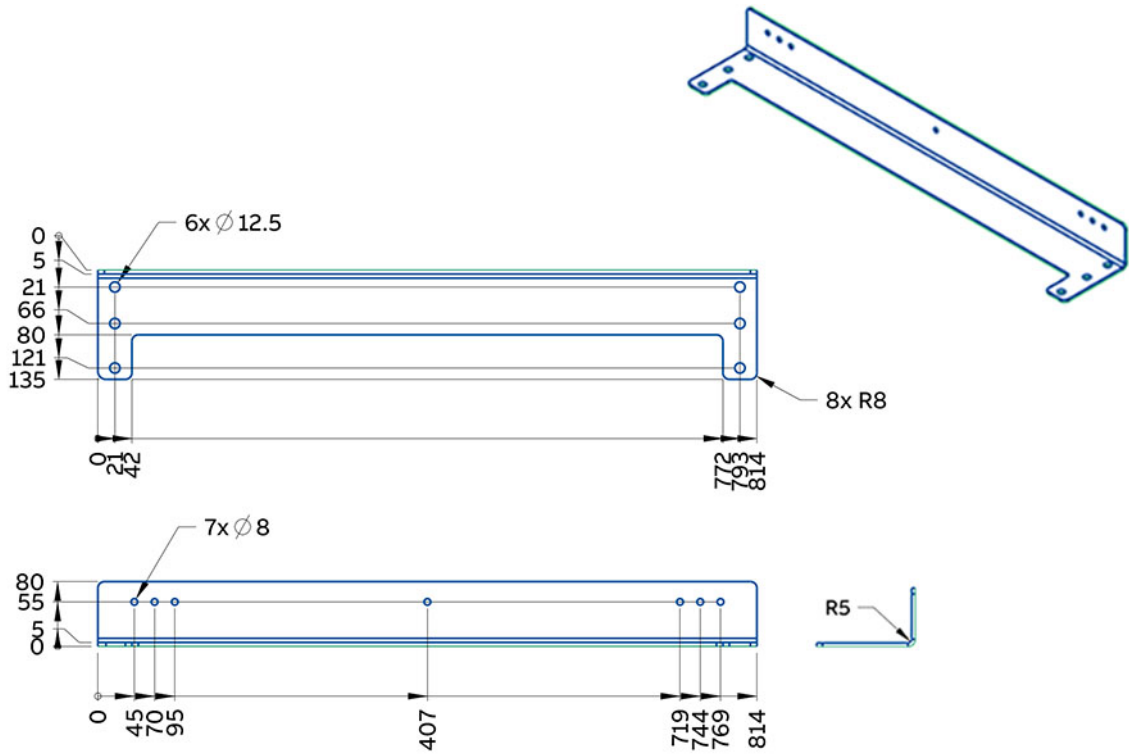
Dimensions in mm

**Figure 2-38 X-PDU Cabinet / System Interface Cabinet - Dimensions and CoG - Front View / Left Side View**



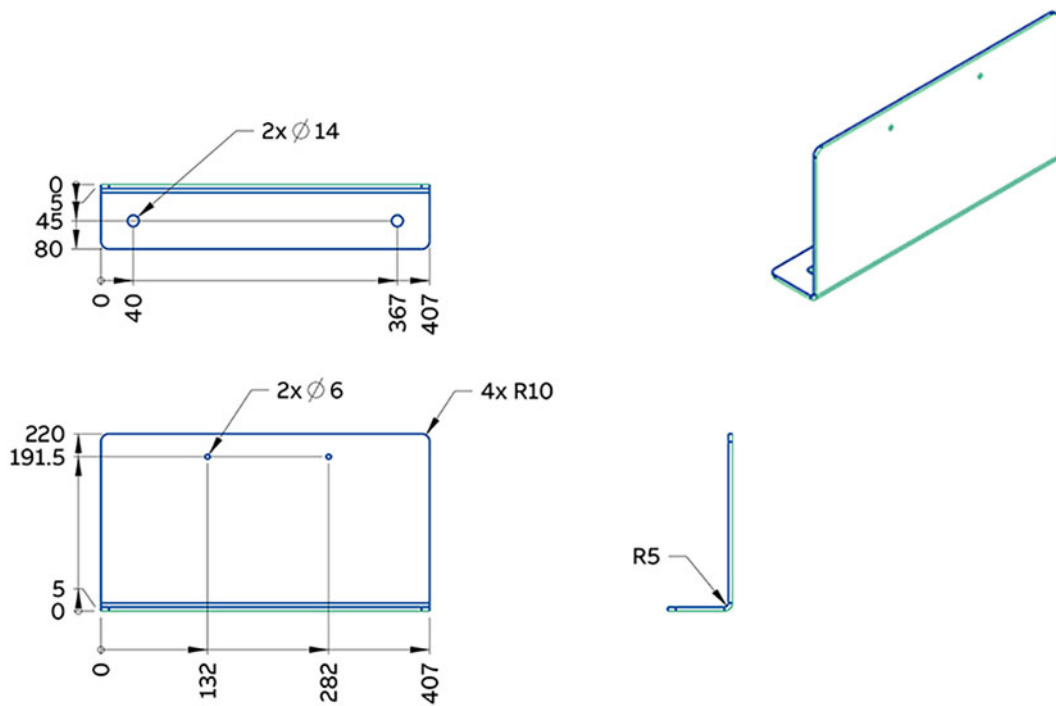
Dimensions in mm (in)

Figure 2-39 X-PDU Cabinet - Seismic Kit Top



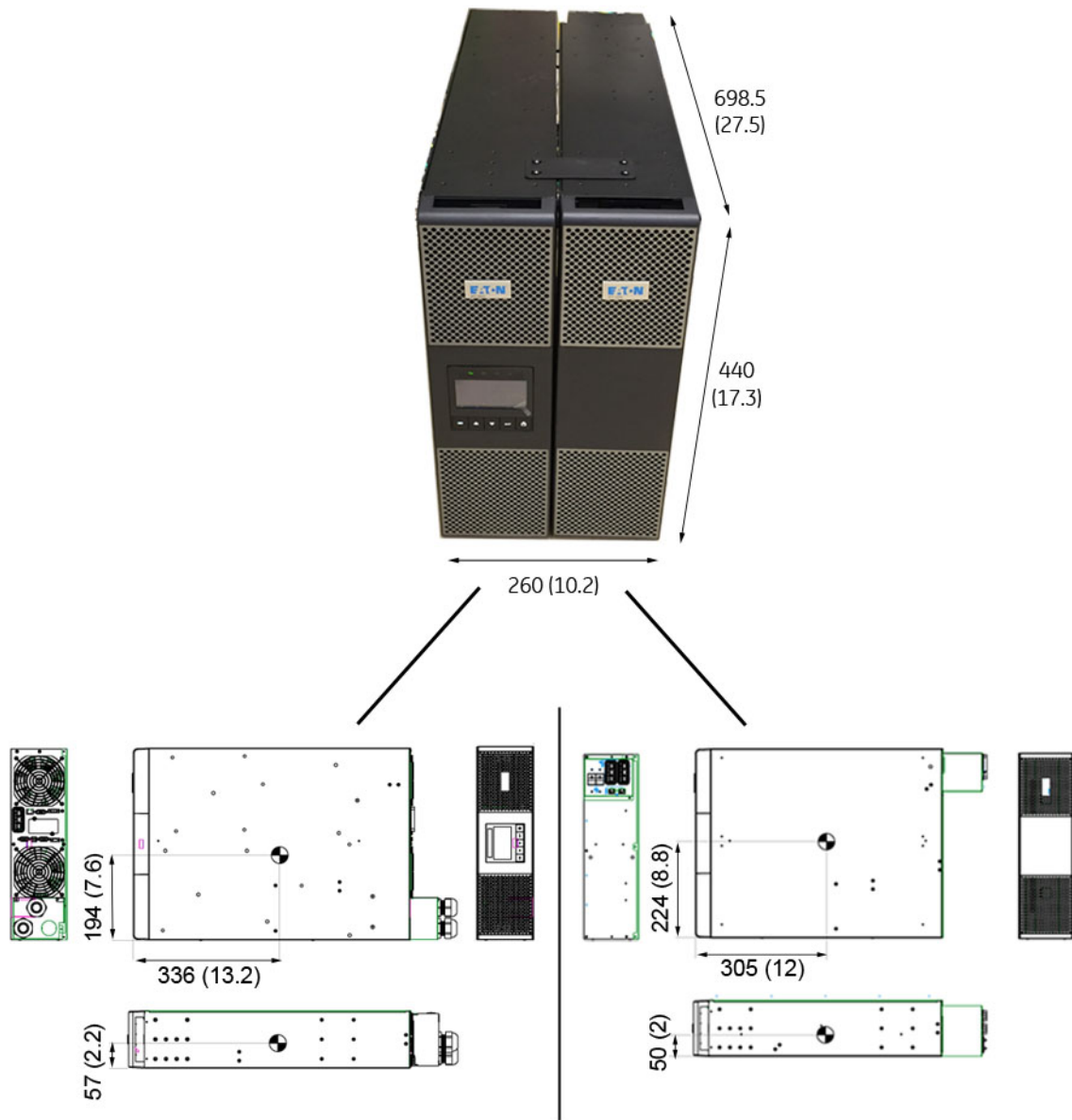
Dimensions in mm

Figure 2-40 X-PDU Cabinet - Seismic Kit Left/Right



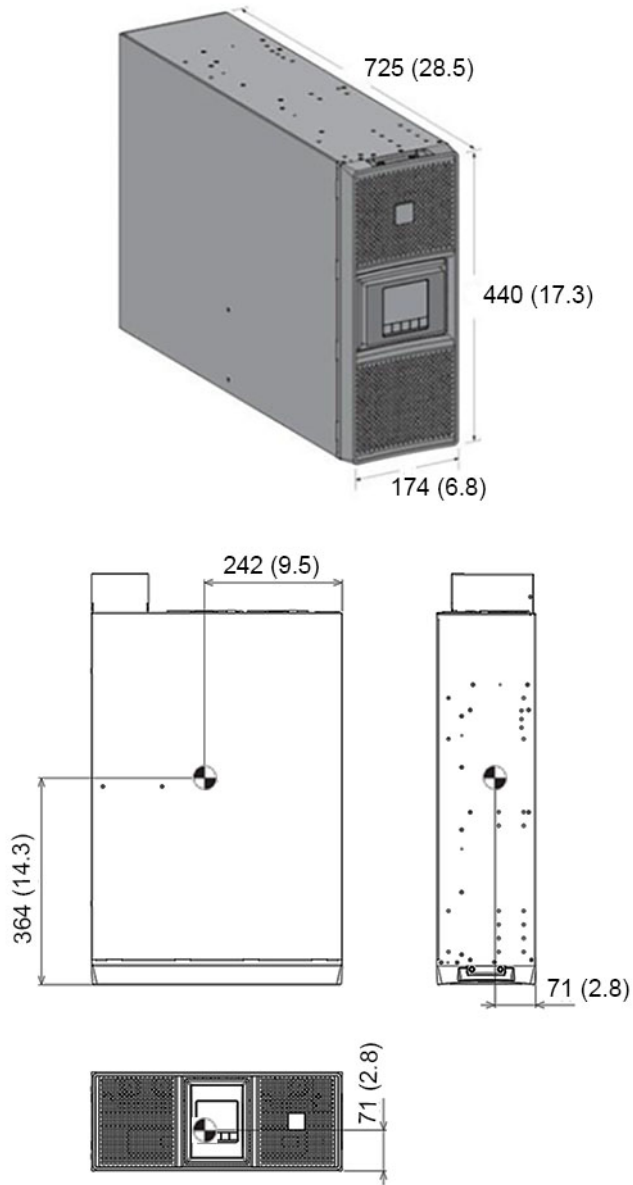
Dimensions in mm

**Figure 2-41 8 kVA Gen1 UPS - Dimensions and CoG**



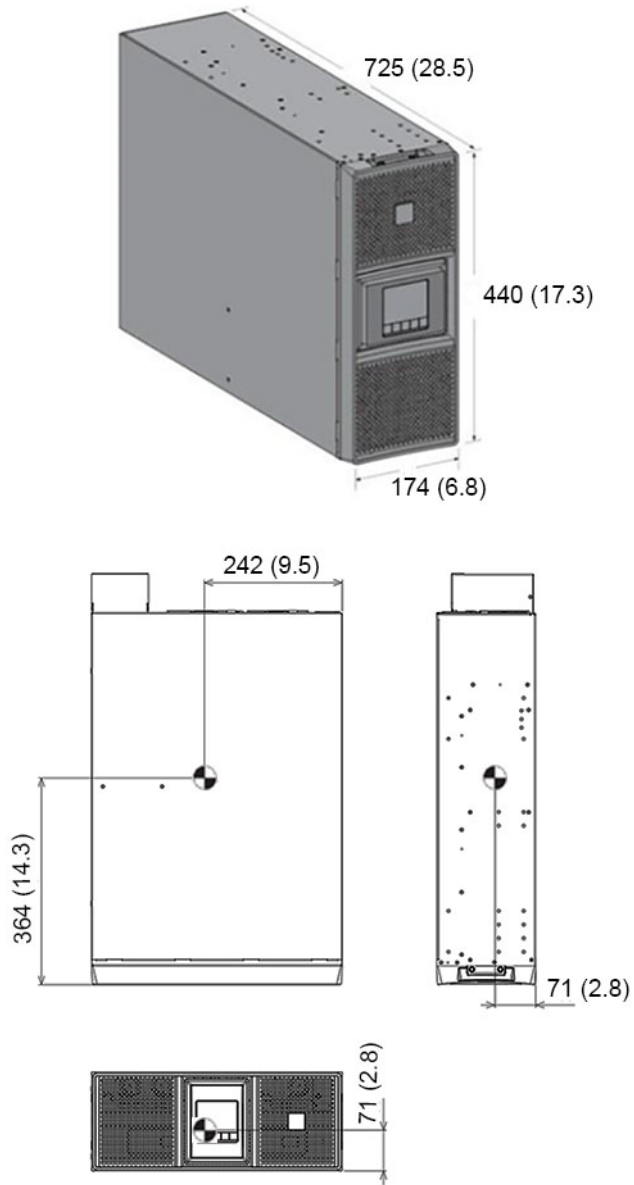
Dimensions in mm (in)

Figure 2-42 Alternate 8 kVA Gen2 UPS - Dimensions and CoG



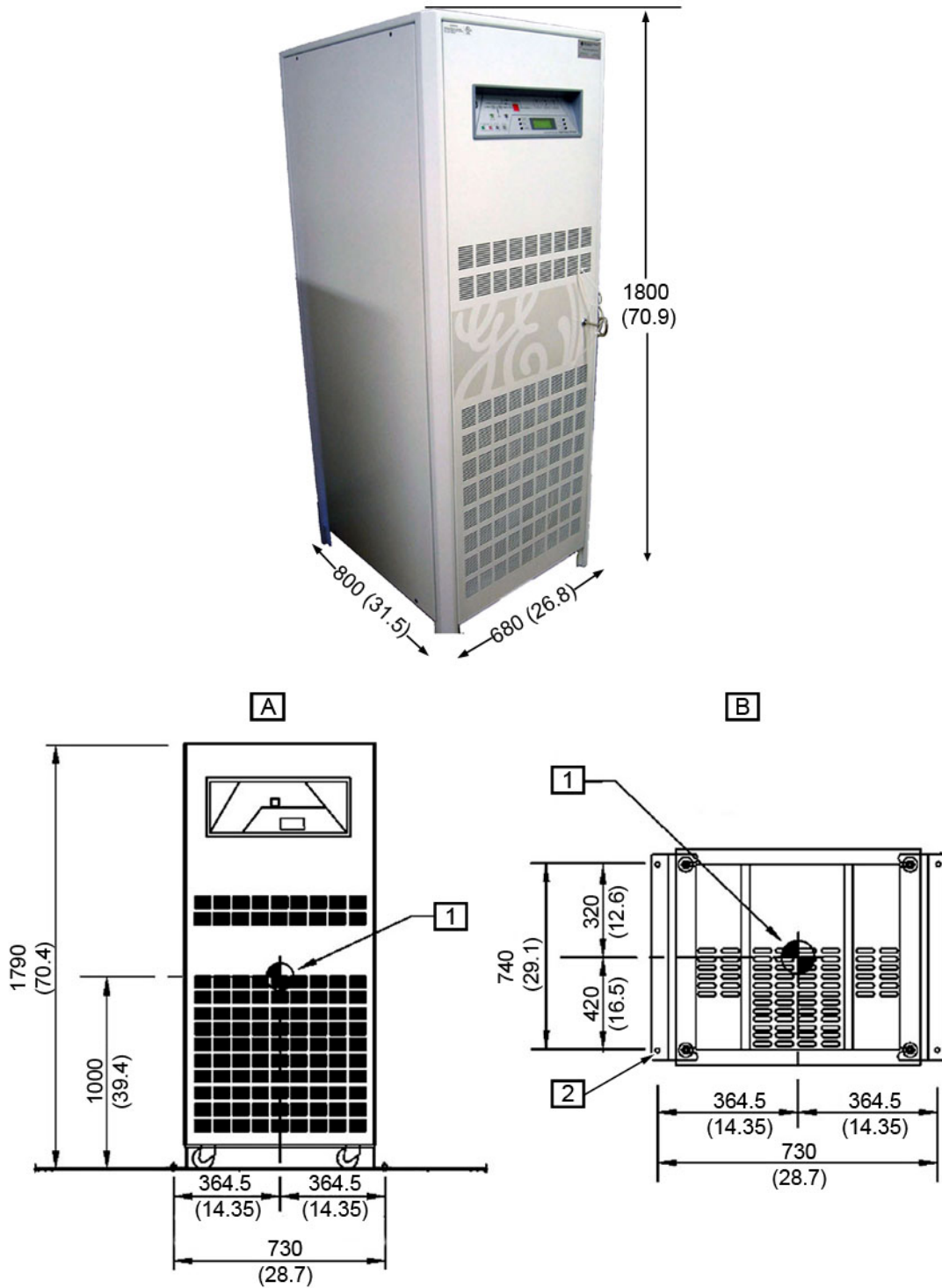
Dimensions in mm (in)

Figure 2-43 Fluoro UPS 11 kVA - Dimensions and CoG

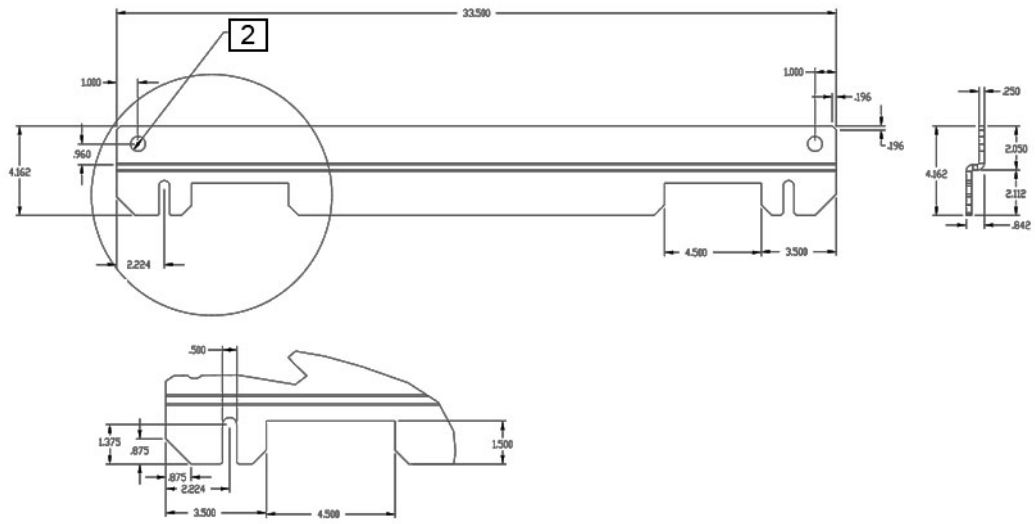


Dimensions in mm (in)

**Figure 2-44 20 kVA Fluoro UPS UL - Dimensions and CoG**

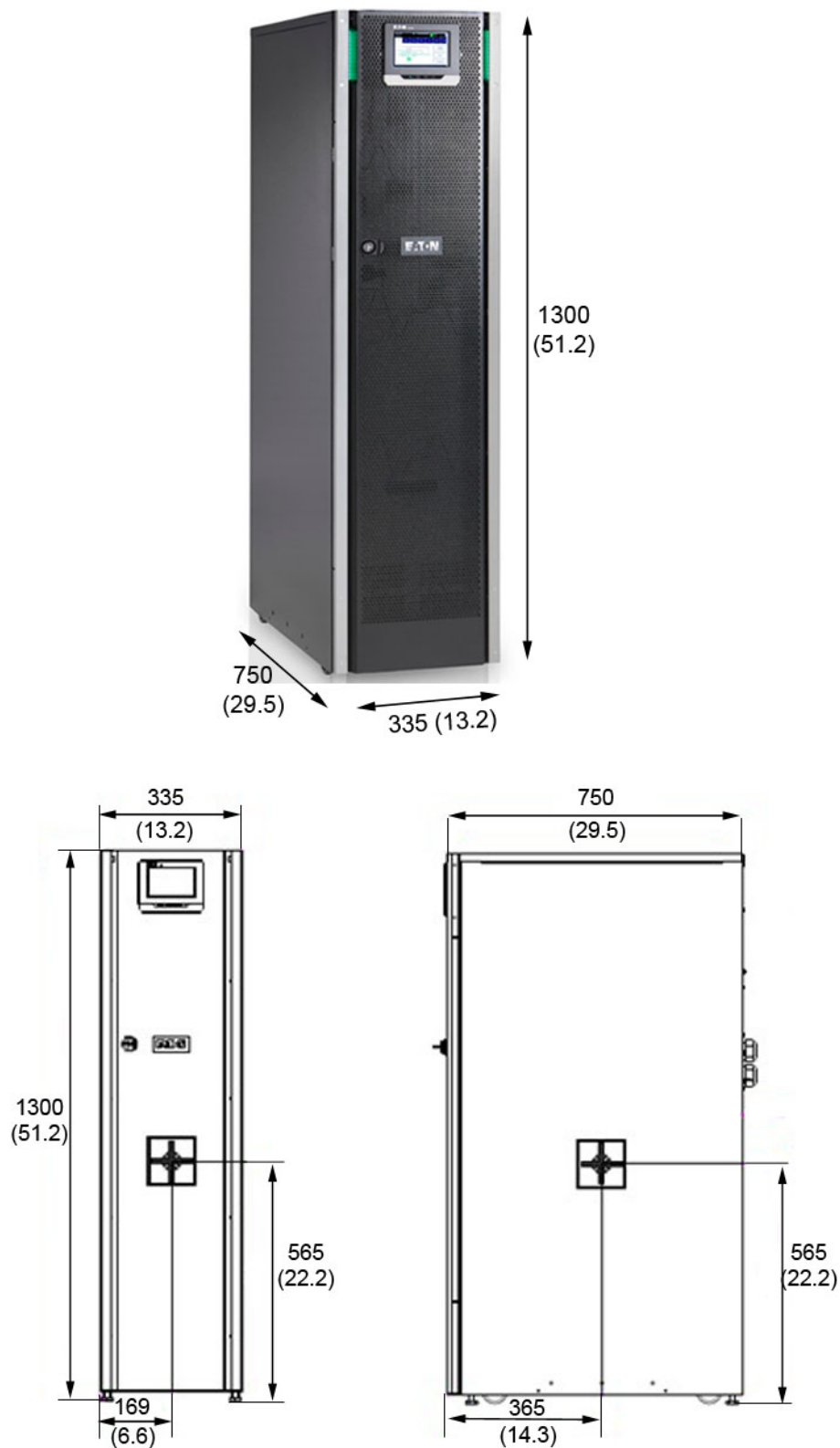


Dimensions in mm (in)



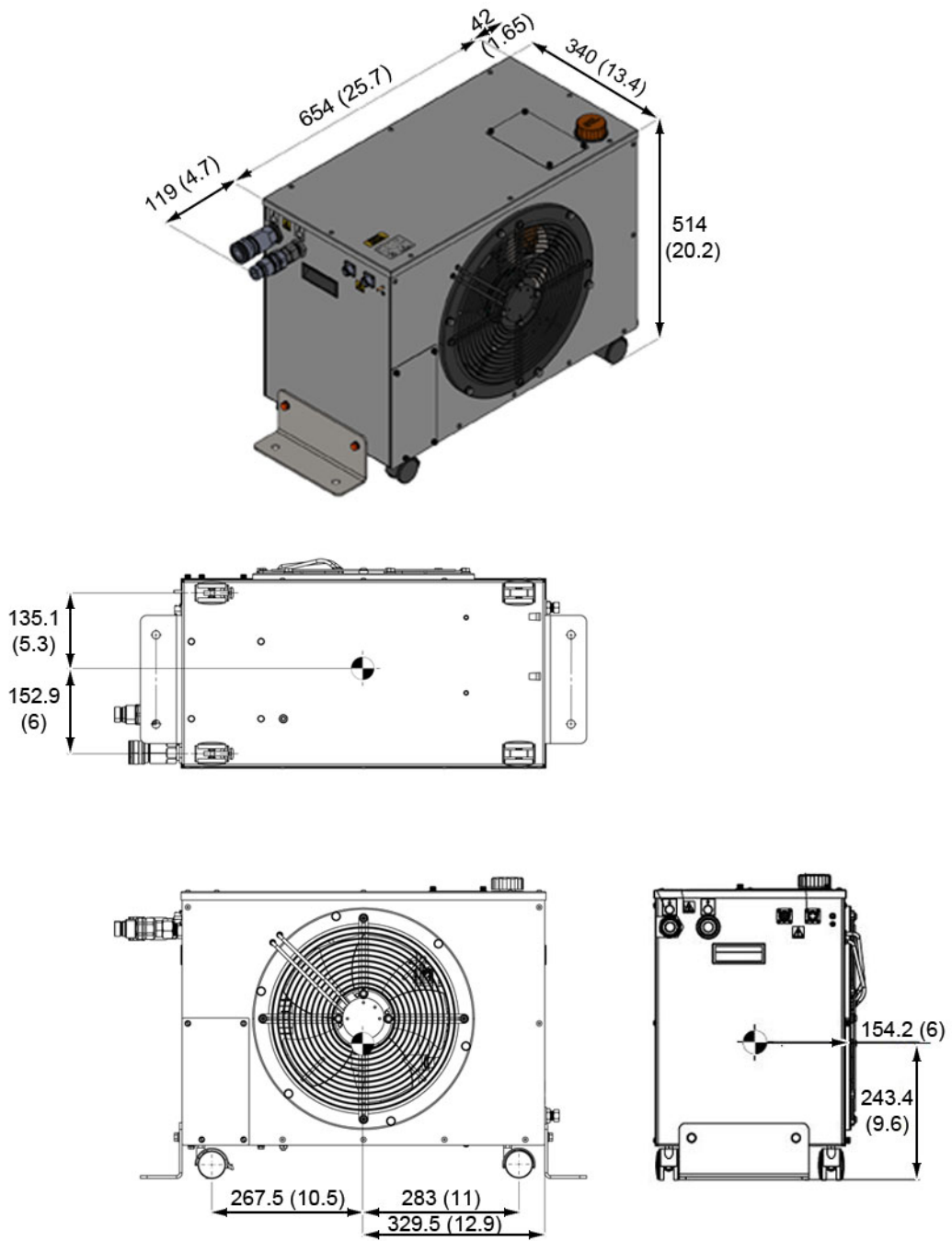
Item	Description
[A]	Front Elevation
[B]	Plan at Base
[1]	Center of Gravity
[2]	Seismic bracket hole diameter: 0.687 inches

Figure 2-45 20 kVA Fluoro UPS CE - Dimensions and CoG



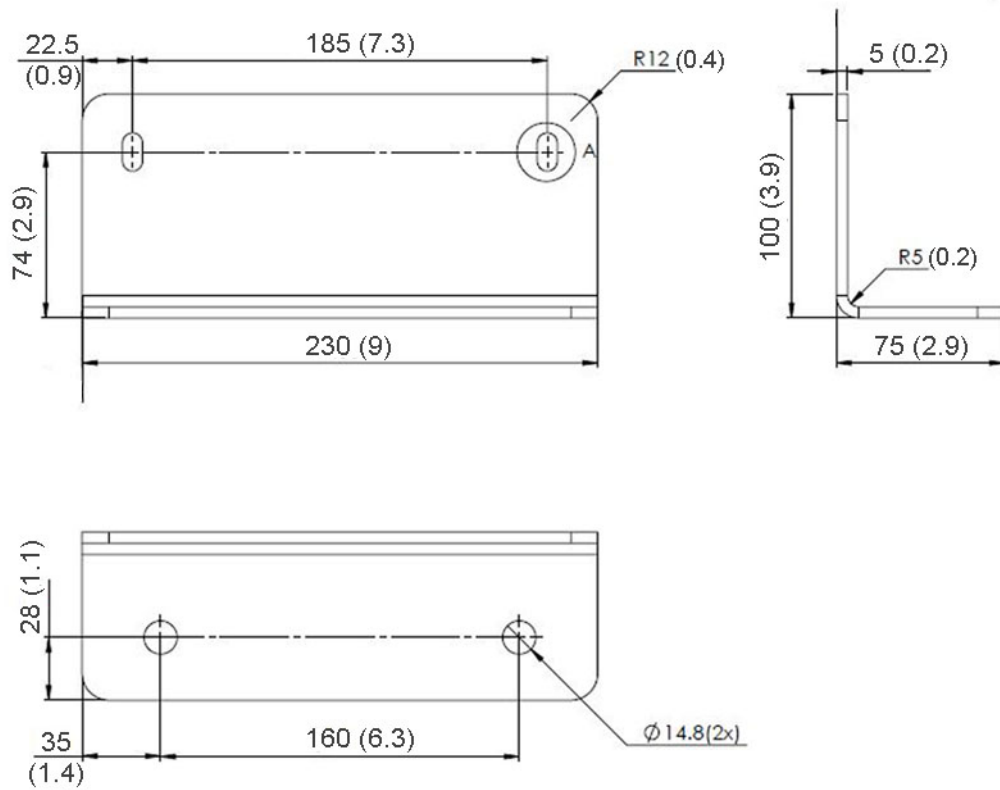
Dimensions in mm (in)

Figure 2-46 X-Ray Tube Cooling Unit - Dimensions and CoG



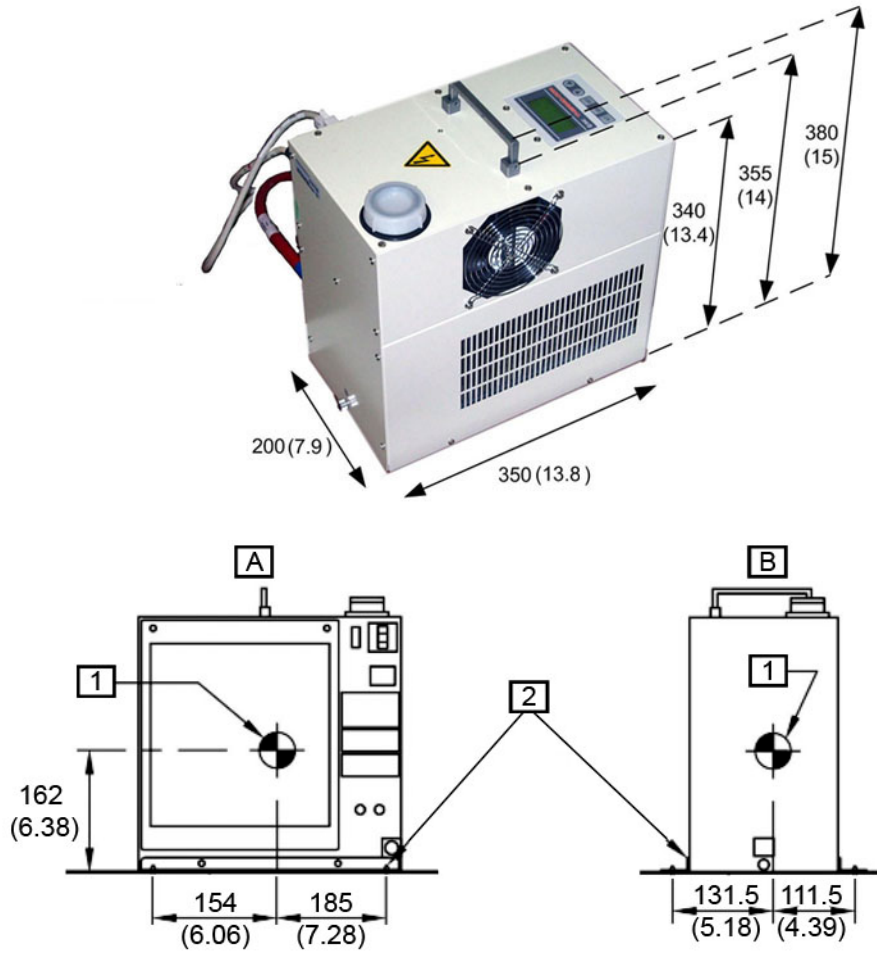
Dimensions in mm (in)

**Figure 2-47 X-Ray Tube Cooling Unit - Anti-seismic kit**



Dimensions in mm (in)

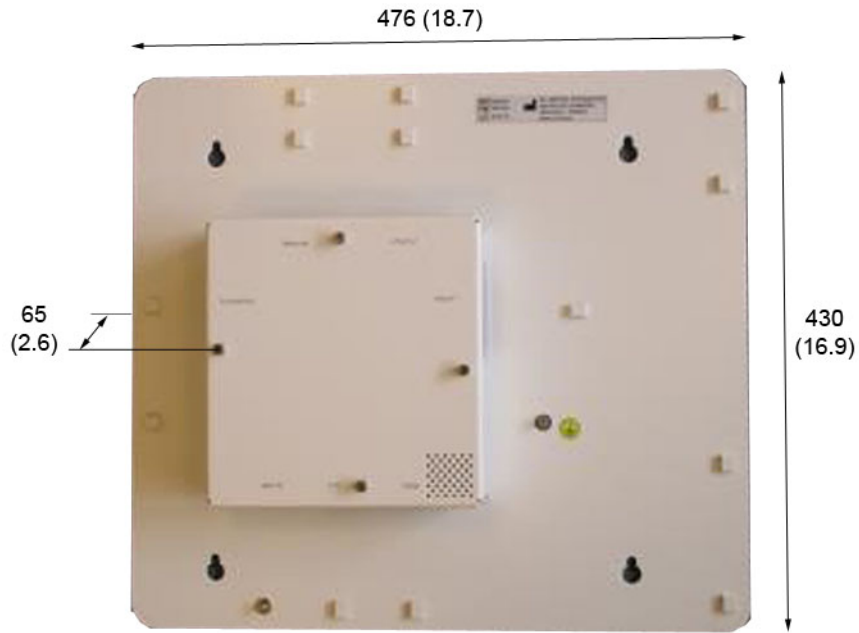
**Figure 2-48 Detector Conditioner - Dimensions and CoG**



Dimensions in mm (in)

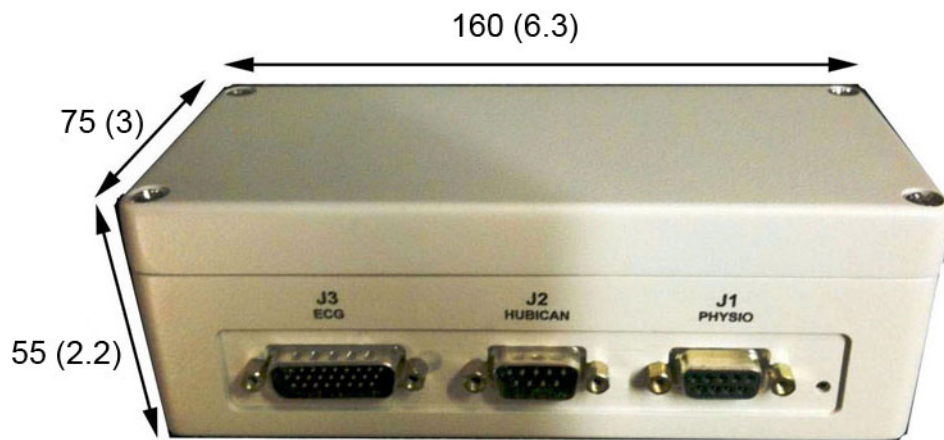
Item	Description
[A]	Front Elevation
[B]	Side Elevation
[1]	Center of Gravity
[2]	Pre-manufactured mounting bracket with 4-3/8" Hilti KB-TZ Expansion Anchors (minimum embedment ( $h_{ef}$ )=2")

**Figure 2-49 I-Box - Dimensions**



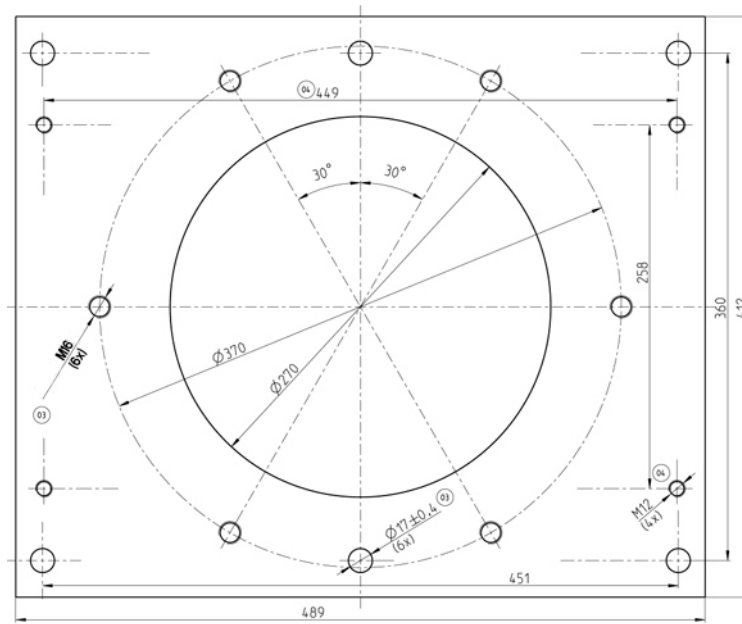
Dimensions in mm (in)

**Figure 2-50 ECG Acquisition Device Module - Physio Box dimensions (Optional)**



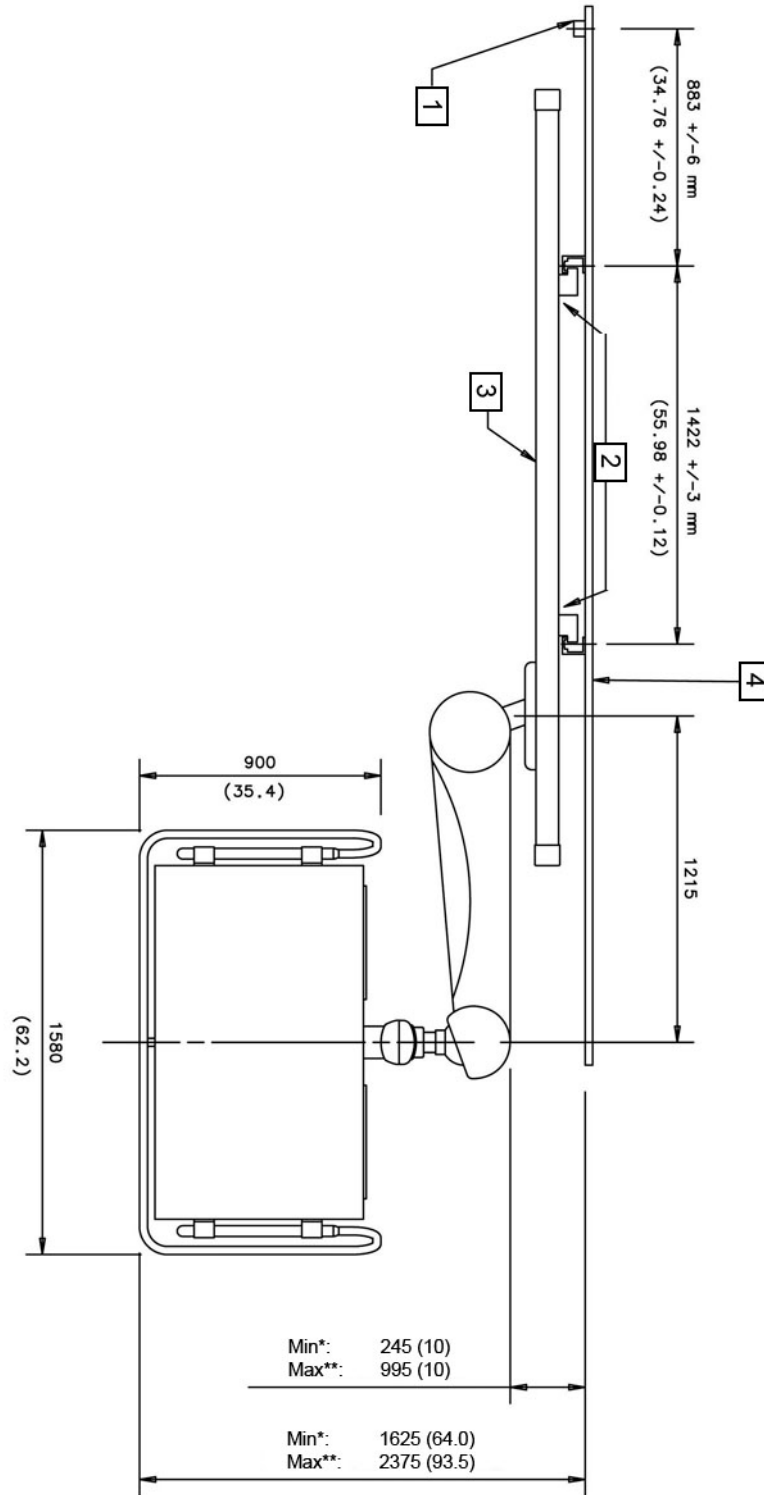
Dimensions in mm (in)

**Figure 2-51 Ceiling Plate of Substructure for Dual Arm suspension - Dimensions**



Dimensions in mm

**Figure 2-52 Large Display Suspension with rails - Dimensions (Optional)**

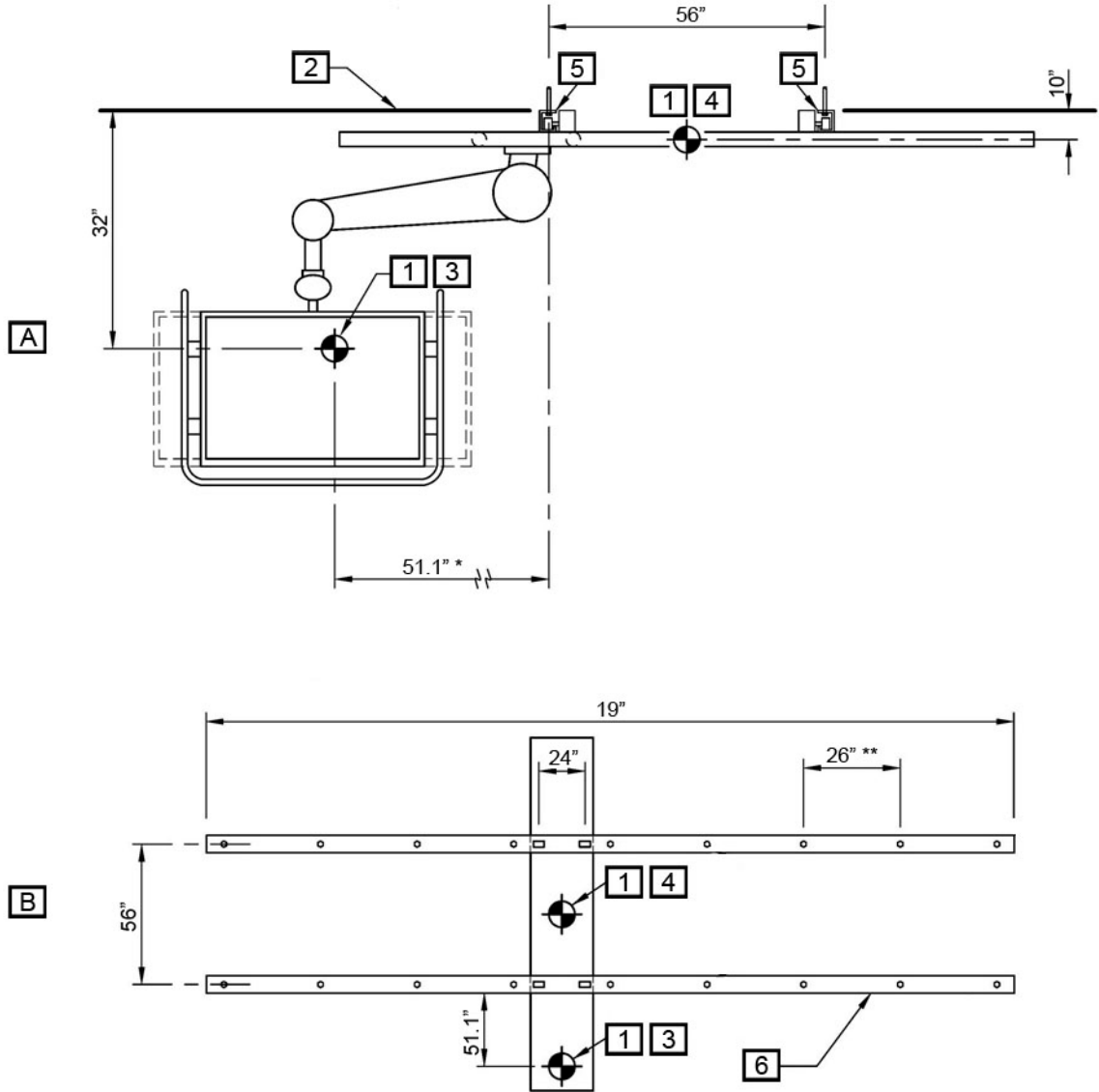


Dimensions in mm (in)

Item	Description
[1]	Support cable drape rails axis (CPEGE55)
[2]	Optional spacer kit
[3]	XT stationary rail
[4]	HALFEN or UNISTRUT structure

Item	Description
*	Minimum
**	Maximum

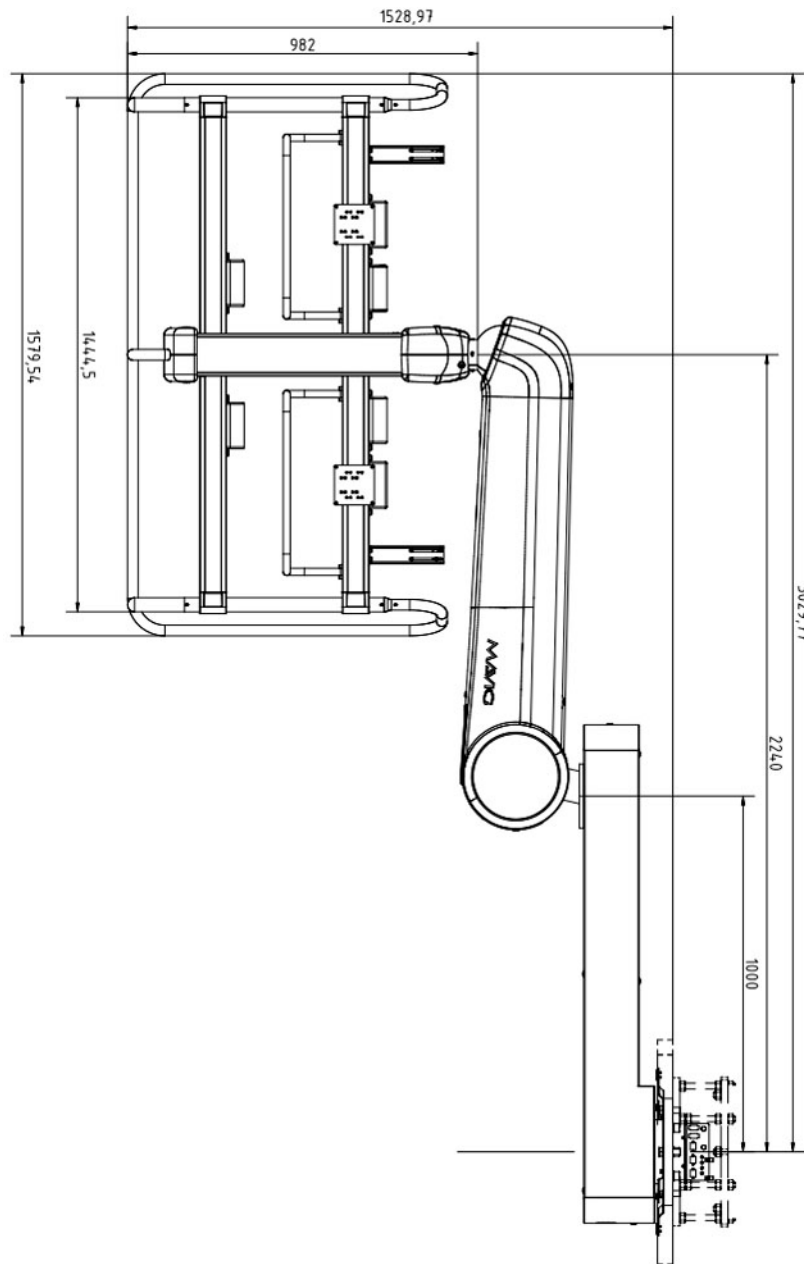
Figure 2-53 Large Display Suspension with rails - CoG



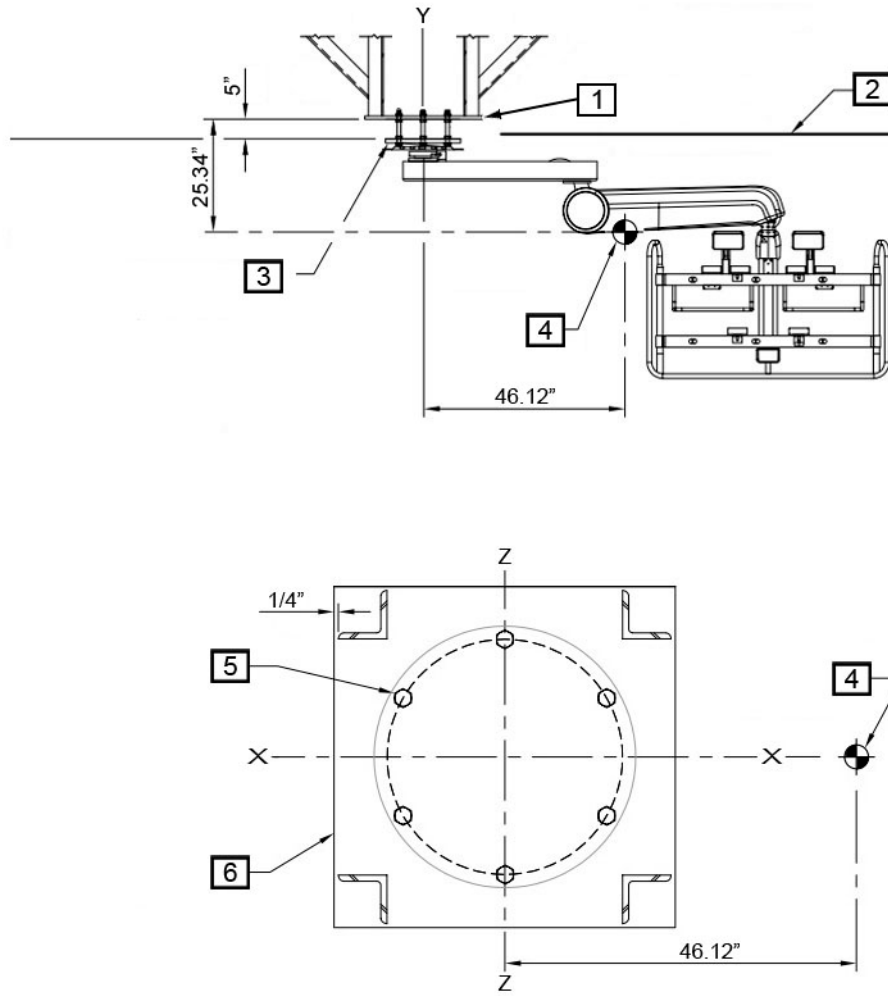
Item	Description
[A]	Elevation
[B]	Plan at Ceiling (ceiling mounted)
[1]	Center of Gravity
[2]	Finished Ceiling
[3]	Monitors and Suspension
[4]	Bridge and Dolly
[5]	Longitudinal Rail
[6]	Ceiling Track (by GE)
*	Maximum

Item	Description
**	Typical

**Figure 2-54 MAVIG suspension with fixed point dual arm for Large Display Monitor - Dimensions (Optional)**

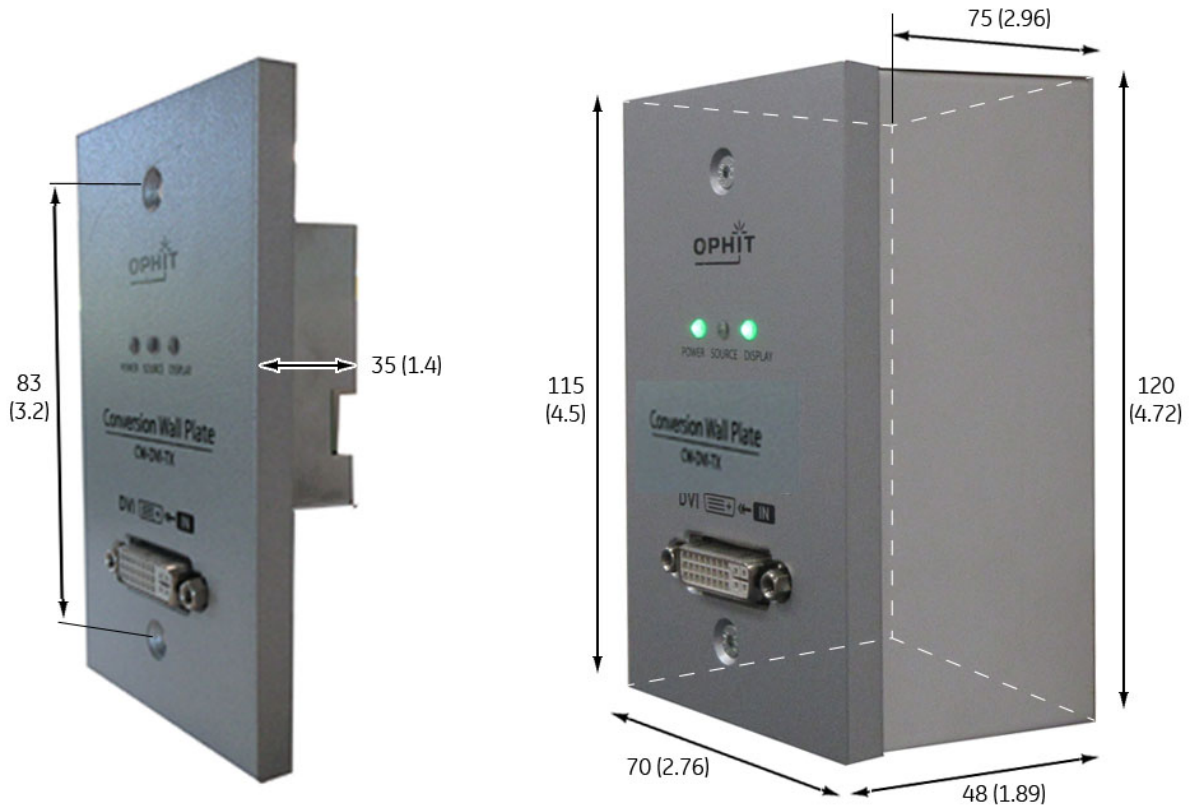


**Figure 2-55 MAVIG suspension with fixed point dual arm for Large Display Monitor - CoG**



Item	Description
[1]	Structural Support Plate at Support Structure
[2]	Finished Ceiling
[3]	Ceiling Flange Plate: 20 mm THK, S235JR Steel, F <sub>y</sub> =52 ksi MIN
[4]	Center of Gravity
[5]	Use 6- M16 (GR 12.9) threaded rods from ceiling flange to support structure
[6]	Structural Plate: 19" x 1" x 1'-7" (A36 MIN)

**Figure 2-56 V-Point Box - Dimensions (Optional)**



Dimensions in mm (in)

## 2.2 Room Layouts

### 2.2.1 Room Dimension Requirements

**Table 2-10 Exam Room dimensions**

Configuration	Room Length mm (in)		Room Width mm (in)		Ceiling Height mm (in)	
	Recommended	Minimum [A]	Recommended	Minimum	Recommended	Minimum
Omega IV table <sup>(1)</sup> [B]	9750 (383.9)	5470 (215.3)	6000 (236.2)	4400 (173.2)	3050 (120.1)	2710 (106.7) with Dual Arm Suspension  2740 (107.9) with rails and Bridge sus- pension
Omega V table <sup>(2)</sup> [C]		6036 (237.6) (+200 (7.9) from head side with Head Ex- tender [E])				
Innova <sup>IQ</sup> table <sup>(3)</sup> [D]		6136 (241.6) (+200 (7.9) from head side with Head Ex- tender [E])				

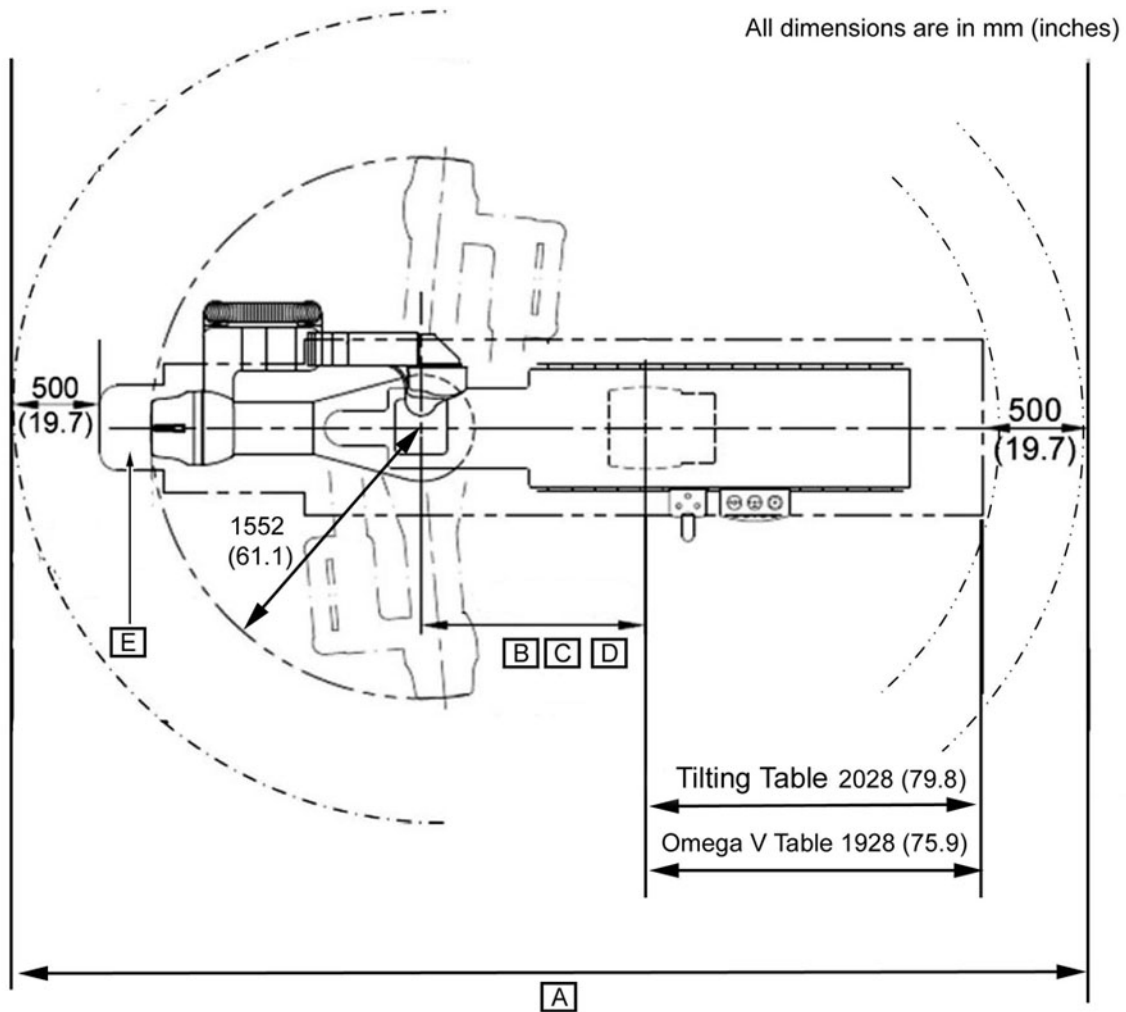
<sup>(1)</sup> Applicable for Cardio 1395 mm (54.9 in).

<sup>(2)</sup> Applicable for both Angio 1278 mm (50.3 in) and Cardio/Neuro 1395 mm (54.9 in).

<sup>(3)</sup> Applicable for both Angio 1278 mm (50.3 in) and Neuro 1395 mm (54.9 in).

For Head Extender Dimensional drawing, refer to [Dimension Drawings on page 55](#).

**Figure 2-57 Minimum Room Length Dimension**



## 2.2.2 Room Layout Drawings

### 2.2.2.1 Exam Room Layout

**NOTICE**

Ensure the air outlet positions in the Exam Room is not close to the monitor suspension carriage or rail.

**(For System with V-Point)** When installed on a wall, the V-Point box should be installed at a suitable height (between 0.80 m and 1.20 m (2.6 ft to 3.9 ft)) from the floor. It should be located near an electrical distribution such as a cable tray or technical sheath, otherwise provide one to route the cables towards the floor or the ceiling. The cable path through the V-Point wall box can be located on one of the four sides of the box or on the back of the box.

The routing of the cable shall respect a minimum bending radius of 30 mm and a minimum dynamic bending of 50 mm radius when mounted on a boom.

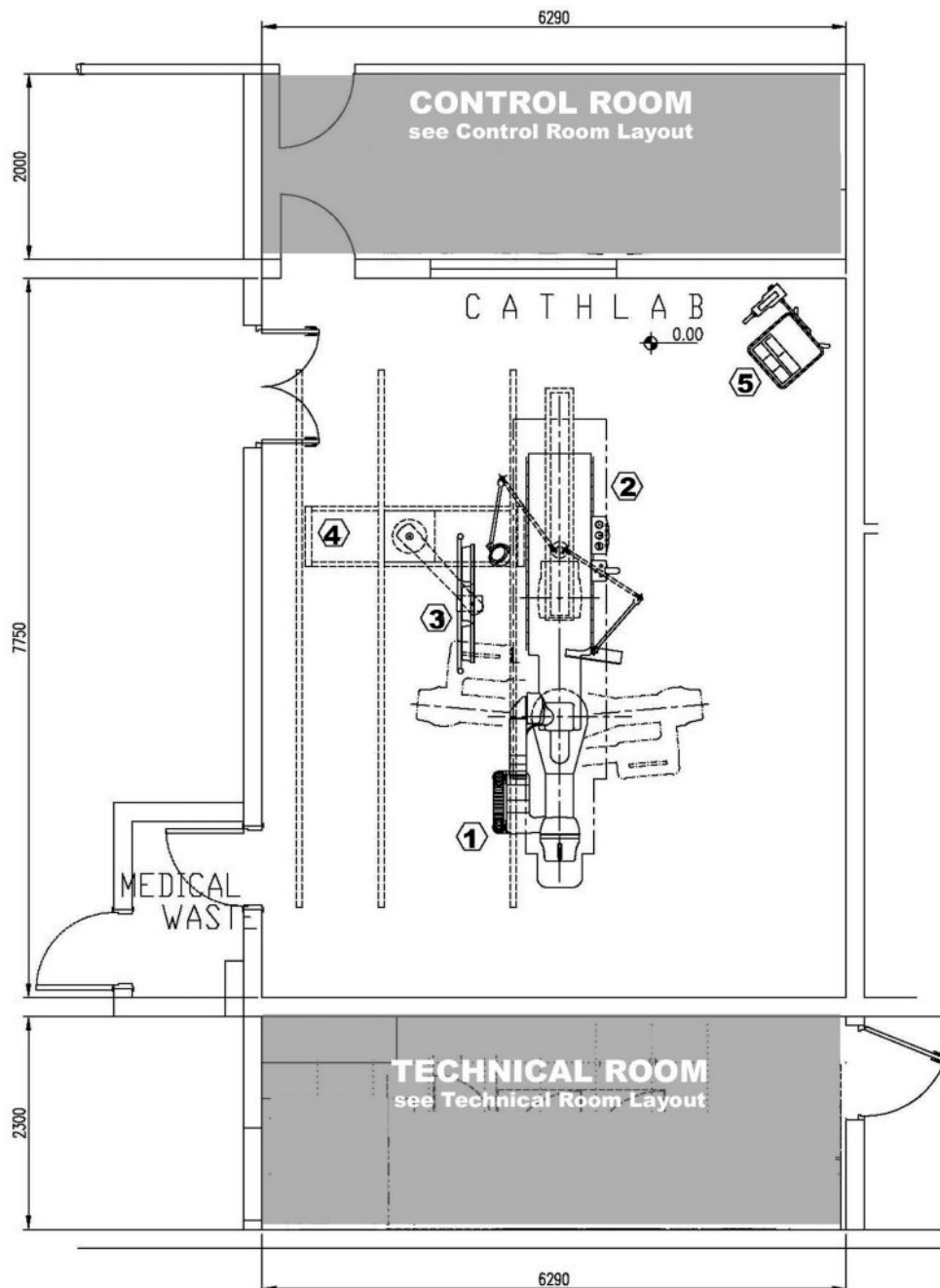
Legend of [Figure 2-58 Exam Room Layout - Monitor suspensions rails parallel to patient table \(to side of table\)](#) on page 97, [Figure 2-59 Exam Room Layout - Monitor suspensions rails parallel](#)

to patient table (over table) on page 98, Figure 2-60 Exam Room Layout - Monitor suspensions rails perpendicular to patient table (Gantry side) on page 99, Figure 2-61 Exam Room Layout - Monitor suspensions rails perpendicular to patient table (table side) on page 100 and Figure 2-64 Exam Room Layout - MAVIG suspension with fixed point with dual arm for Large Display Monitor on page 102:

1. Gantry
2. Patient Table
3. Monitor suspension
4. Monitor frame
5. Injector on pedestal

### 2.2.2.1.1 Exam Room Layout - Monitor Suspension with rails

Figure 2-58 Exam Room Layout - Monitor suspensions rails parallel to patient table (to side of table)

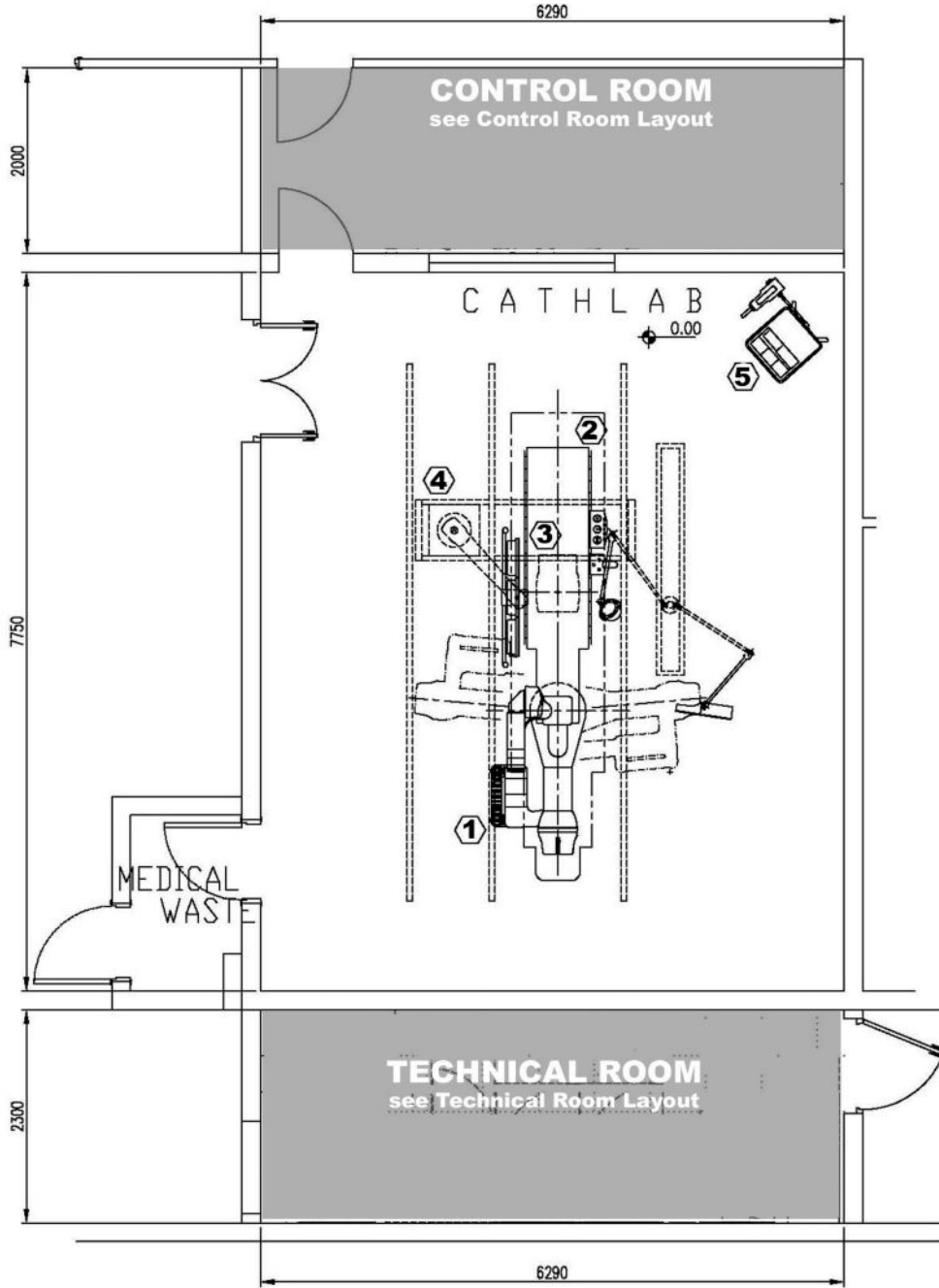


**WARNING**

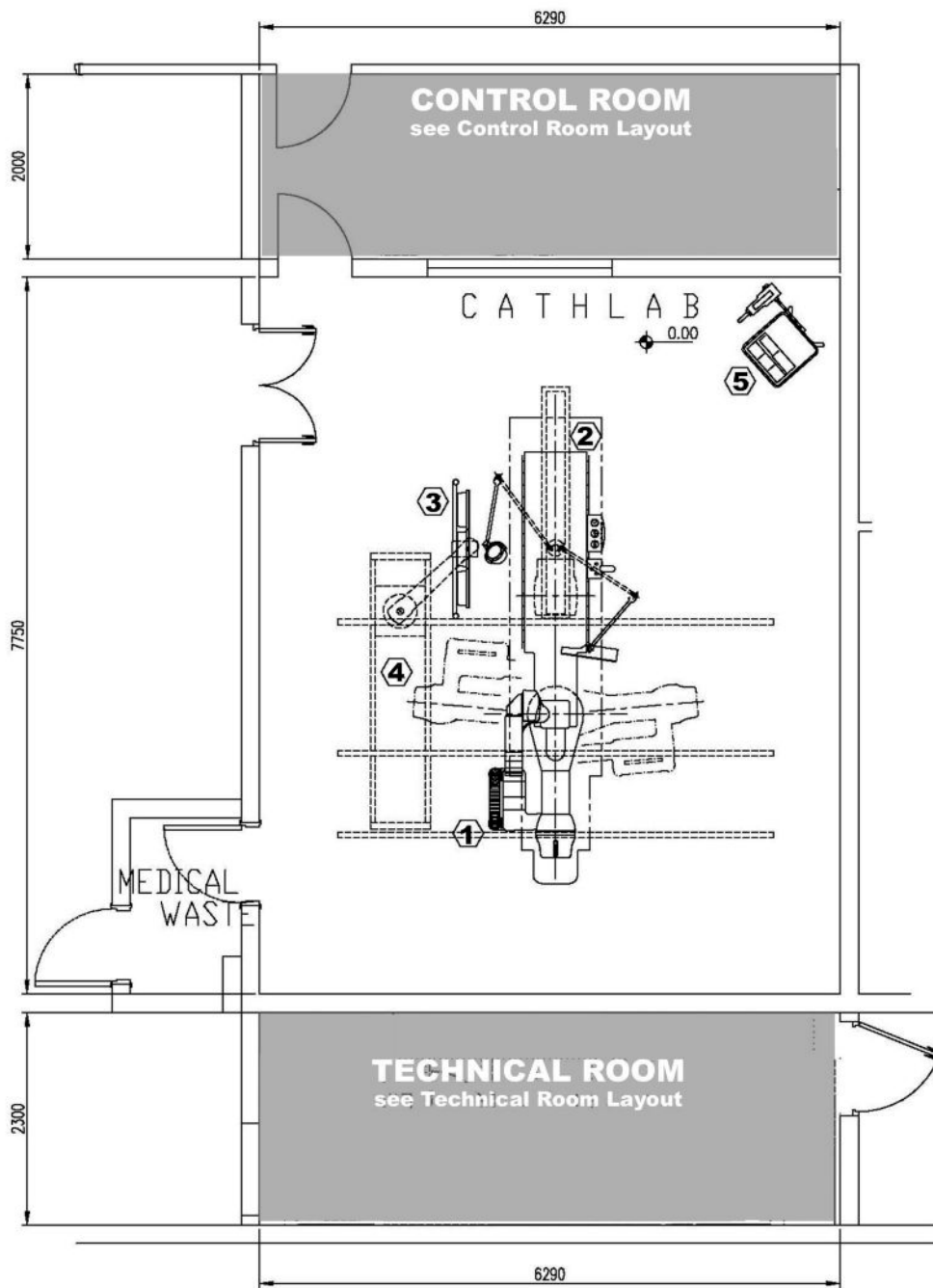


Figure 2-58 Exam Room Layout - Monitor suspensions rails parallel to patient table (to side of table) on page 97 is mandatory with hospital having air flow installation.

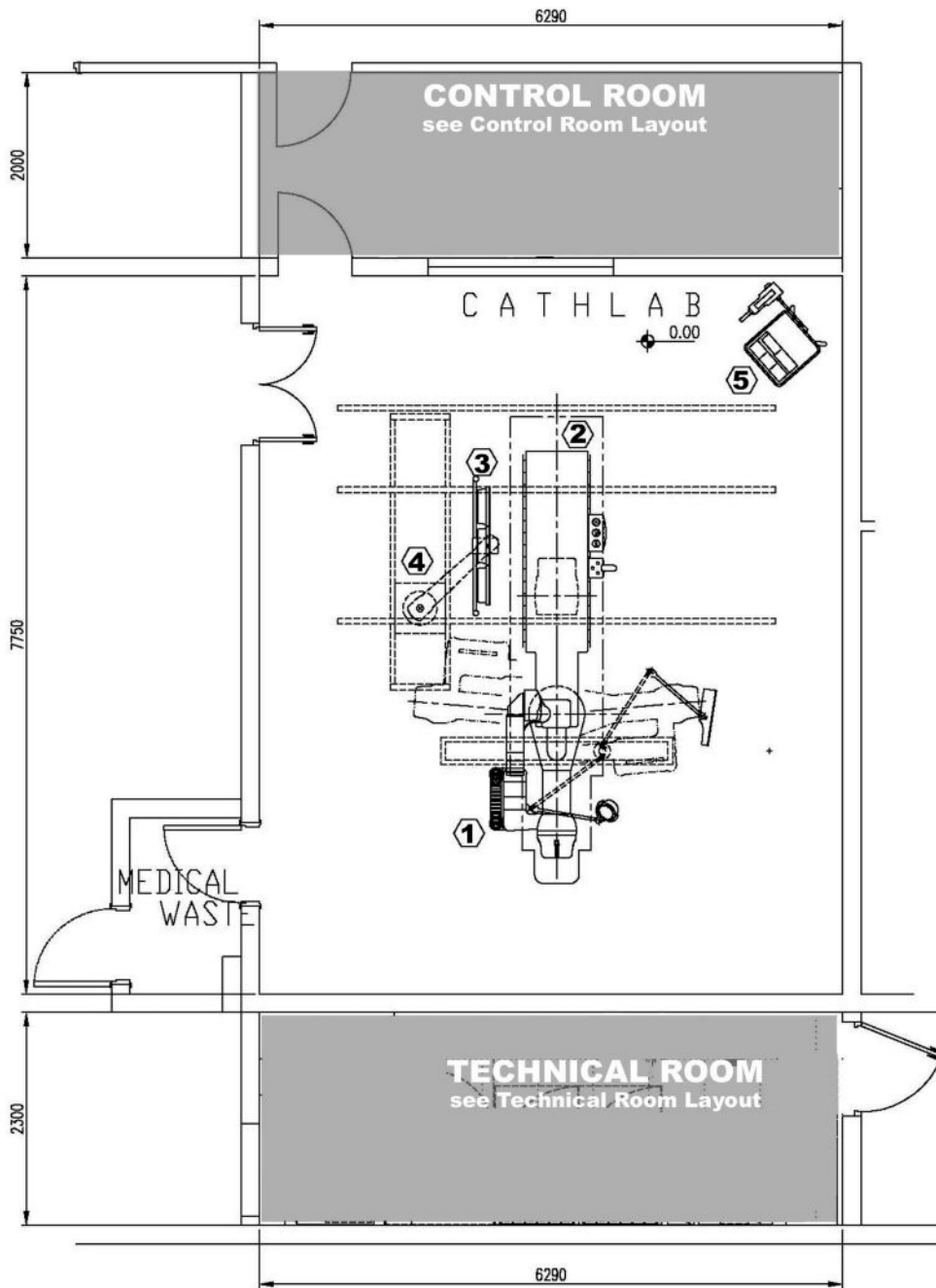
**Figure 2-59 Exam Room Layout - Monitor suspensions rails parallel to patient table (over table)**



**Figure 2-60 Exam Room Layout - Monitor suspensions rails perpendicular to patient table (Gantry side)**



**Figure 2-61 Exam Room Layout - Monitor suspensions rails perpendicular to patient table (table side)**



**2.2.2.1.2 Exam Room Layout - Monitor Suspension with fixed point dual arm**

The suspension ceiling fixation shall be determined taking into account at least:

- Clinical need: with an overall radius coverage of 2.03 m for Large Display Monitor suspension. Ensure the monitor(s) will be able to reach the position required by medical staff.
- Parking position.
- Ceiling constraints: other component and air flow.
- Cable output and ceiling trap.

The recommended position for the sub-structure ceiling plate installation as in below drawings:

- If the typical procedure of customer is on the patient right, the recommend position refer to [Figure 2-62 on page 101](#).
- If the typical procedure of customer is on the patient left, the recommend position refer to [Figure 2-63 on page 101](#).

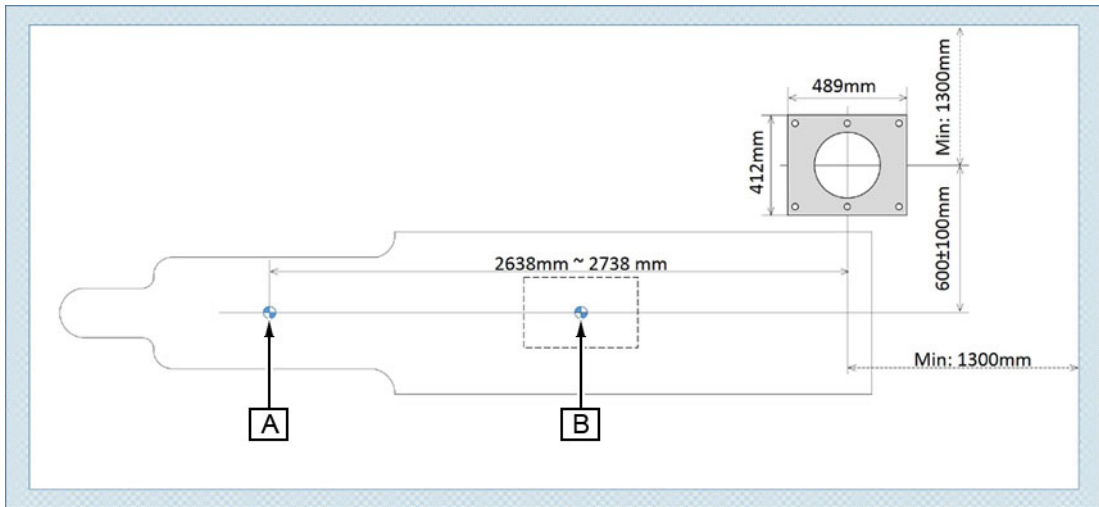


**NOTE**

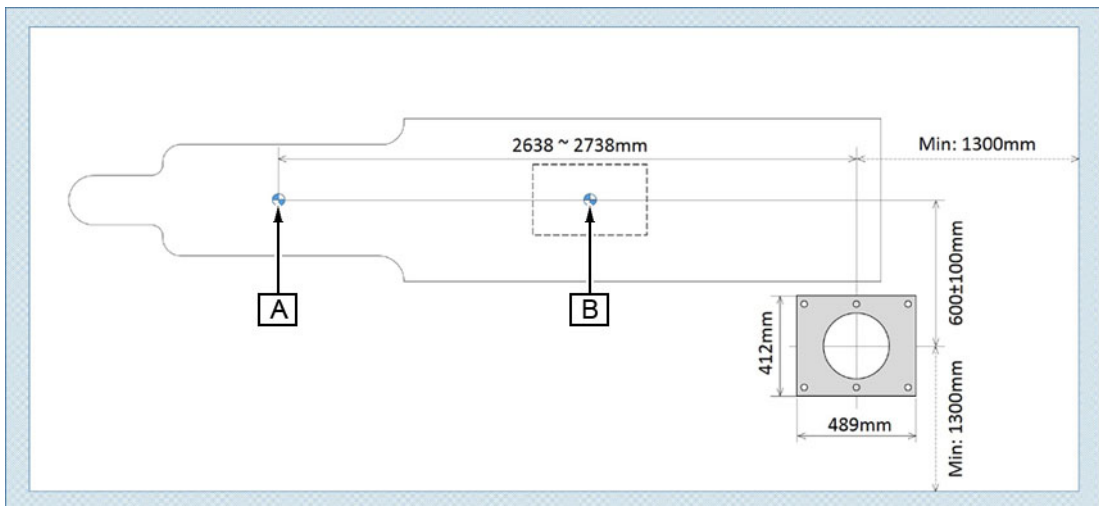
The longitude edge of the ceiling plate should be parallel to the table top longitude axis.

The distance from center of substructure to the wall should be at least 1300 mm as in the drawing, otherwise, suspension arm could not be rotated full range.

**Figure 2-62**

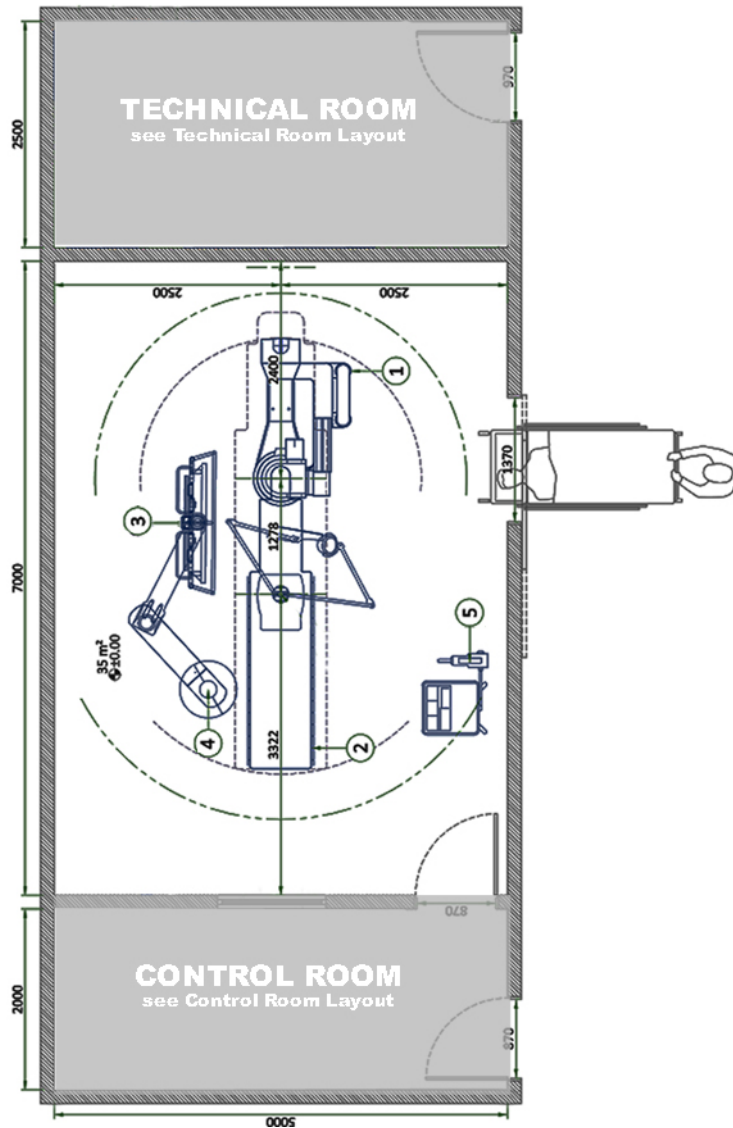


**Figure 2-63**



Item ( <a href="#">Figure 2-62 on page 101</a> and <a href="#">Figure 2-63 on page 101</a> )	Description
A	ISO Center
B	Table Center

**Figure 2-64 Exam Room Layout - MAVIG suspension with fixed point with dual arm for Large Display Monitor**



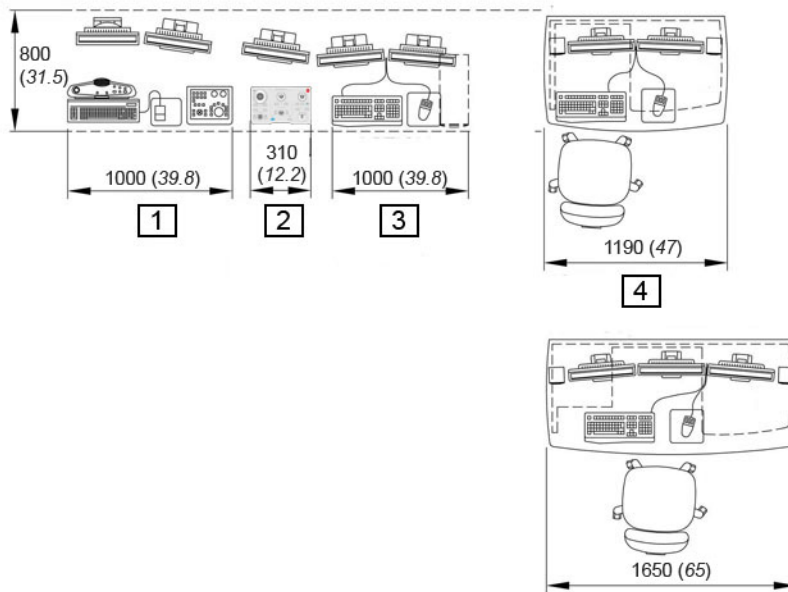
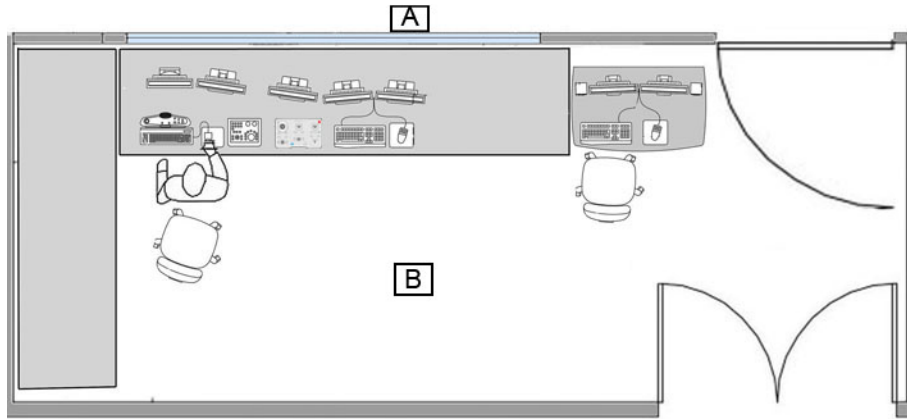
### 2.2.2.2 Control Room Layout

Motion controls installed in remote location from the Table shall be installed at a location where all the positioner axis are visible by the operator.

**(For System with InnovalQ Table)** The remote motion controls shall not be installed on the longitudinal axis of the Table (to avoid any operator visual dead angle due to tilted table top hiding the patient).

**(For System with V-Point)** The V-Point wall box should be installed on the wall and at a suitable height (between 0.80 m and 1.20 m (2.6 ft to 3.9 ft)) from the floor. It should be near an electrical distribution such as a cable tray or technical sheath, otherwise provide one to route cables towards the floor or the ceiling. Cable path through the V-Point wall box can be located on one of the four sides of the box or on the back of the box. The routing of the cable shall respect a minimum bending radius of 30 mm.

**Figure 2-65 Control Room Layout**



Dimensions in mm (in)

Item	Description
[A]	Patient room
[B]	Control room
[1]	Basic configuration
[2]	Control Panel
[3]	Review workstation option
[4]	MACLAB system option or Combolab/Cardiolab option

### 2.2.2.3 Technical Room Layout

**NOTICE**

CONDENSATION MAY OCCUR ON THE OUTLETS AND PIPES OF THE AIR CONDITIONING SYSTEM, THEREFORE, IT IS CRITICAL TO INSTALL THE CABINETS WHERE THERE IS NO RISK OF WATER DROPS FROM THE AIR CONDITIONER.

### 2.2.2.3.1 General Requirements

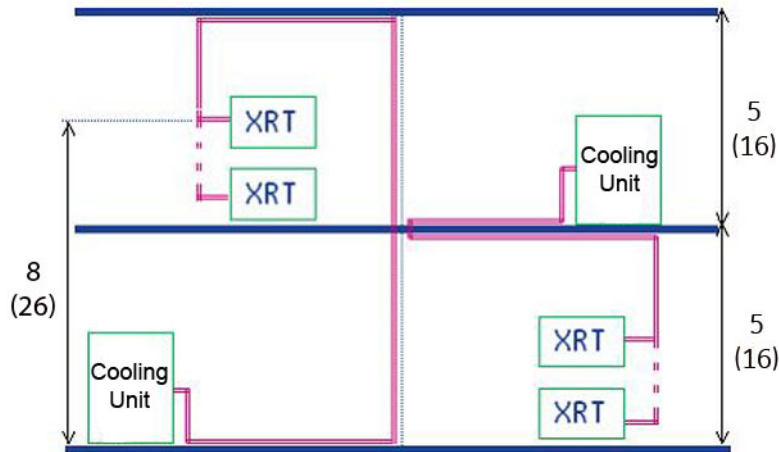
It is not allowed to store objects on cabinet top, or to stack cabinets one on another.

In cases 2 cabinets are installed face to face (both sides of the access way), the clearance width shall be at least 1.2 m.

In order to maintain their cooling capacities:

- The Tube Cooling Unit shall be no more than 5 m (16 feet) above or 7 m (23 feet) below the upper position of the X-Ray Tube.

**Figure 2-66 Distance between Tube Cooling Unit and X-Ray Tube**



Dimensions in m (ft)



**NOTE**

The highest point of the oil circuit can be 10 m (32 feet) above the floor of the Technical Room where the Cooling Unit is located (case where the Technical Room is one floor under the Exam Room).



**NOTE**

**(For USA only)** According to NFPA codes, the excess of Polyurethane hose from the tube cooling system should be stored in a metal electrical junction box attached to the wall or in the ceiling.

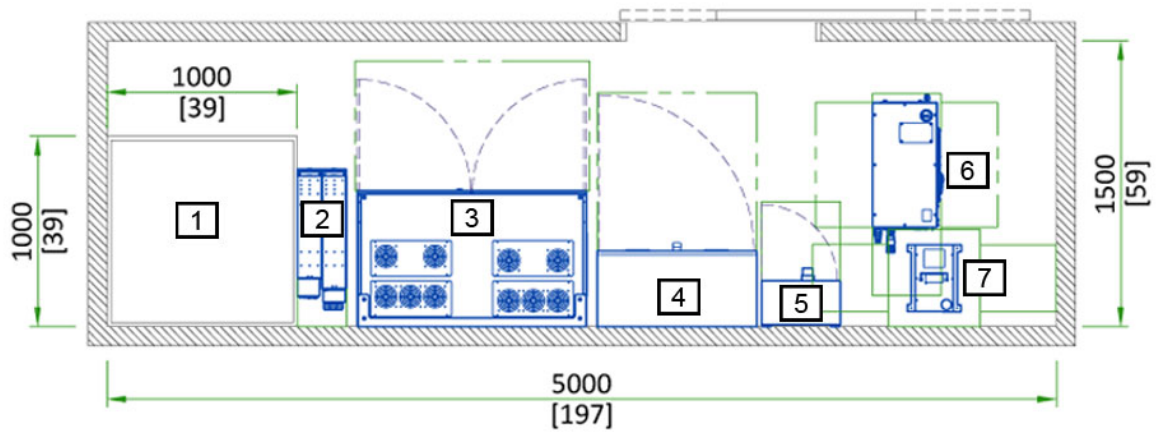
- The Detector Conditioner shall be no more than 3 m in height below the Detector.

Legend for [Figure 2-67 Technical Room Layout - Configuration 8 kVA Gen1 UPS and PDU V2](#) on page 105, [Figure 2-68 Technical Room Layout - Alternate Configuration 8 kVA Gen2 UPS and PDU V2](#) on page 105, [Figure 2-69 Technical Room Layout - Configuration 20 kVA UPS \(Fluoro UPS UL\) and PDU V2](#) on page 106, [Figure 2-70 Technical Room Layout - Configuration 20 kVA UPS \(Fluoro UPS CE\) and PDU V2](#) on page 106 and [Figure 2-71 Technical Room Layout - Configuration Fluoro UPS 11 kVA and X-PDU](#) on page 106:

Item	Description
[1]	System tools and documentation
[2]	UPS
[3]	C-FRT Cabinet
[4]	PDU
[5]	MDP
[6]	X-Ray Tube Cooling Unit

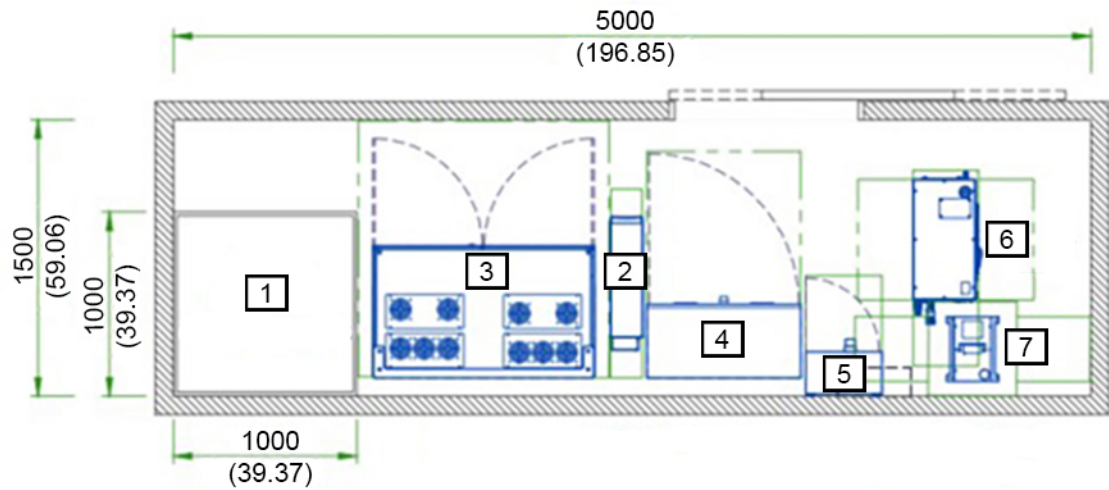
Item	Description
[7]	Detector Conditioner

Figure 2-67 Technical Room Layout - Configuration 8 kVA Gen1 UPS and PDU V2



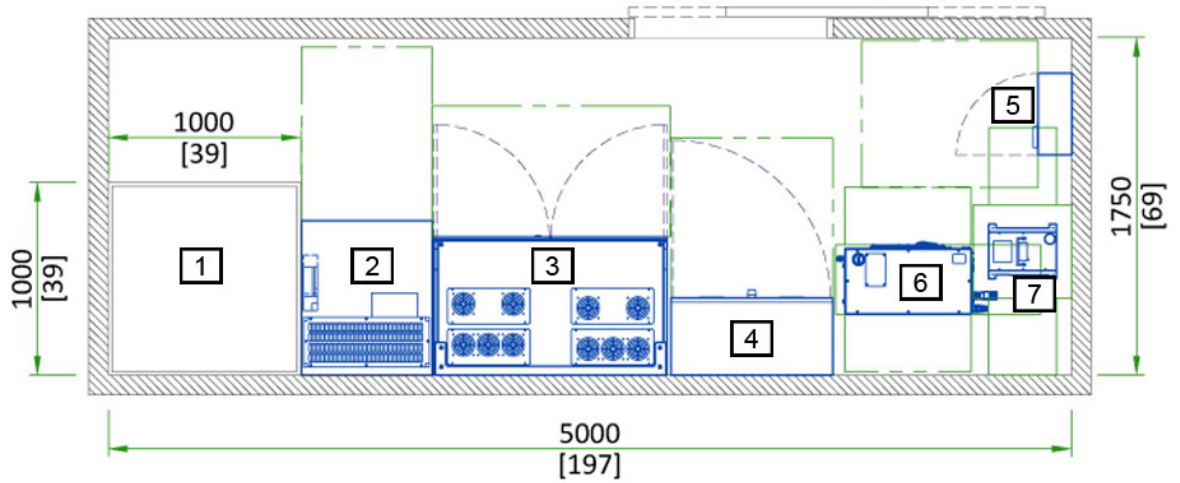
Dimensions in mm (in)

Figure 2-68 Technical Room Layout - Alternate Configuration 8 kVA Gen2 UPS and PDU V2



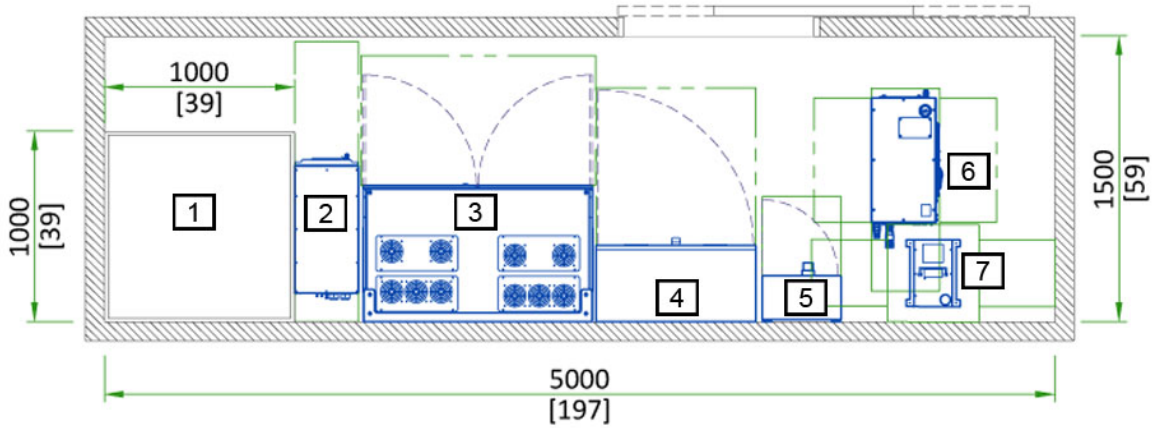
Dimensions in mm (in)

Figure 2-69 Technical Room Layout - Configuration 20 kVA UPS (Fluoro UPS UL) and PDU V2



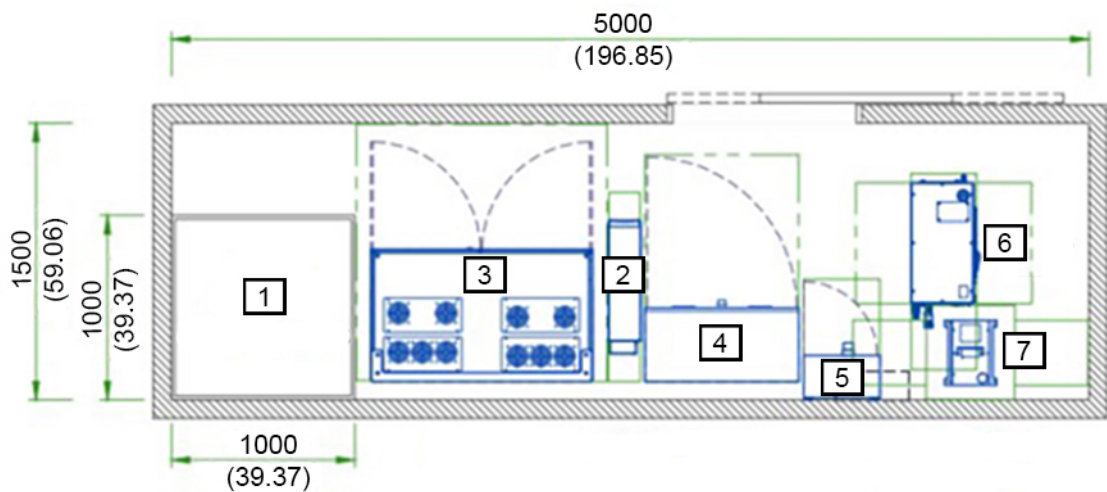
Dimensions in mm (in)

Figure 2-70 Technical Room Layout - Configuration 20 kVA UPS (Fluoro UPS CE) and PDU V2



Dimensions in mm (in)

Figure 2-71 Technical Room Layout - Configuration Fluoro UPS 11 kVA and X-PDU



Dimensions in mm (in)

### 2.2.2.3.2 Requirements for Equipment Airflow

If the Technical Room is in a dusty environment, it is strongly recommended to install filters on the air inlet of the Technical Room. These filters can cause reduced speed at the air inlet, and the size of the air inlet has therefore to be dimensioned accordingly

The following distances shall be respected to guarantee proper cooling air exhaust.

C-FRT Cabinet:

- The minimum clearance between the ceiling and the top of the C-FRT Cabinet is 30 cm (11.8 in).

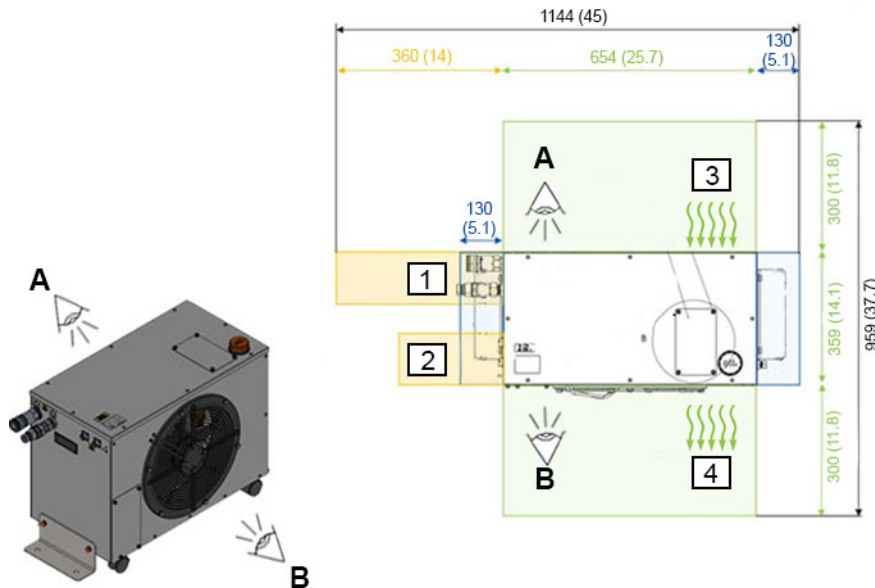
PDU V2 or X-PDU:

- The minimum clearance between the ceiling and the top of the PDU V2 or X-PDU is 30 cm (11.8 in).

Tube Cooling Unit:

- The Cooling unit shall be placed in a way that air intake and air discharge are not obstructed. Otherwise, the cooling capacity may be restricted. The clearance with the wall of the units is shown in figure below.

**Figure 2-72 Tube Cooling Unit – Minimum clearance**



Dimensions in mm (in)

**[A]:** Rear

**[B]:** Front

**[1]:** Hydraulic connection

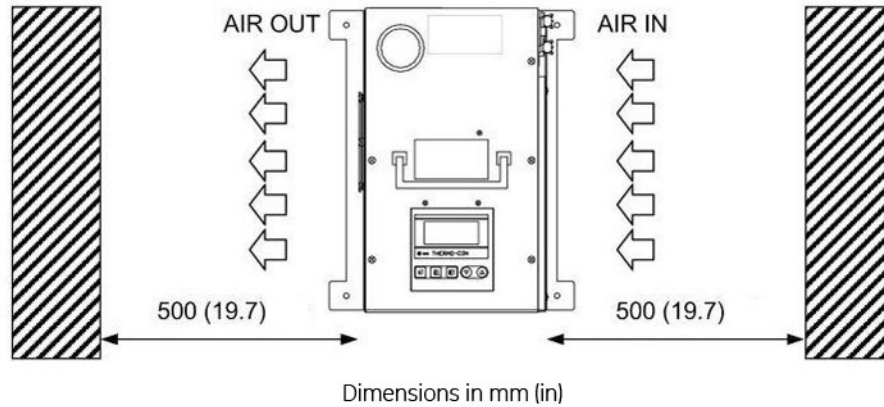
**[2]:** Electrical connection

**[3]:** Air Flow IN

**[4]:** AIR Flow OUT

Detector Conditioner:

- The following 50 cm clearance on the sides must be respected.

**Figure 2-73 Detector Conditioner – Minimum clearance****20 kVA Fluoro UPS:**

- Make sure there is a ventilation air flow, preferably ensured by natural air flow, otherwise by enforced ventilation, so that hydrogen concentration is below 1% (according to the Standard IEC 62040-1-2).
- 20 kVA Fluoro UPS UL: The minimum clearance between the ceiling and the top of the UPS is 40 cm (15.7 in). The left, right or back sides of the UPS can be positioned against the wall or another cabinet.
- 20 kVA Fluoro UPS CE: The left and right side of the UPS can be positioned against the wall or another cabinet. The following minimum clearance shall be respected:
  - 50 cm (19.7 in) between the top of the UPS and the ceiling
  - 15 cm (5.9 in) between the back of the UPS and the wall
  - 65 cm (25.6 in) from the front of the UPS

**8 kVA UPS or Fluoro UPS 11 kVA:**

- The following minimum clearance shall be respected:
  - 150 mm (5.9 in) between the back of the UPS and the wall
  - 150 mm (5.9 in) from the front of the UPS

**2.2.2.3.3 Requirements for Service Access**

A free area in front of the following cabinets shall allow to open fully their doors for service access:

- PDU
- X-PDU
- C-FRT Cabinet
- MDP
- 20 kVA Fluoro UPS

**C-FRT Cabinet:**

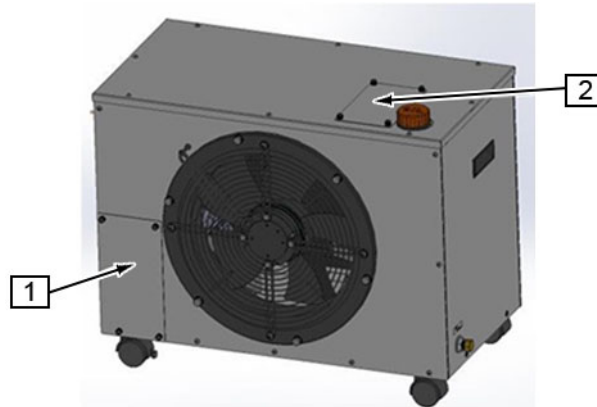
- A clearance of 80 mm on the lateral sides of the C-FRT Cabinet. It allows the installation of the anchoring brackets and the full opening of the doors for service access

**Tube Cooling Unit:**

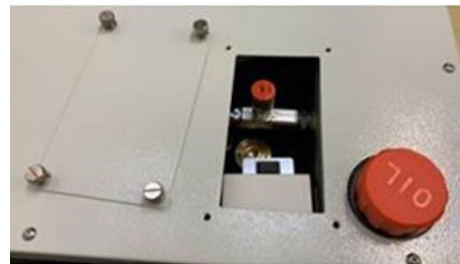
- No specific requirements for access on the left and right side where the handles are located.
- The cooling unit has two maintenance covers, one to access the filter strainer **[1]** and one to access the test button **[2]**. These covers can be removed by manually unscrewing the captive screws.

- The cooling unit is equipped with wheels that allow to move it during maintenance to allow access on both sides.

**Figure 2-74 Tube Cooling Unit - Covers**



**[1]:** Cover to access filter strainer



**[2]:** Cover to access test button

## 2.2.2.4 ECG Device Room Configurations

The ECG connection is compatible with an ECG device in the Control Room or in the Exam Room.

The Analog Output Box option is mandatory to provide an analog output connection to the Physio module (If not present, it can be ordered through the following FRUs):

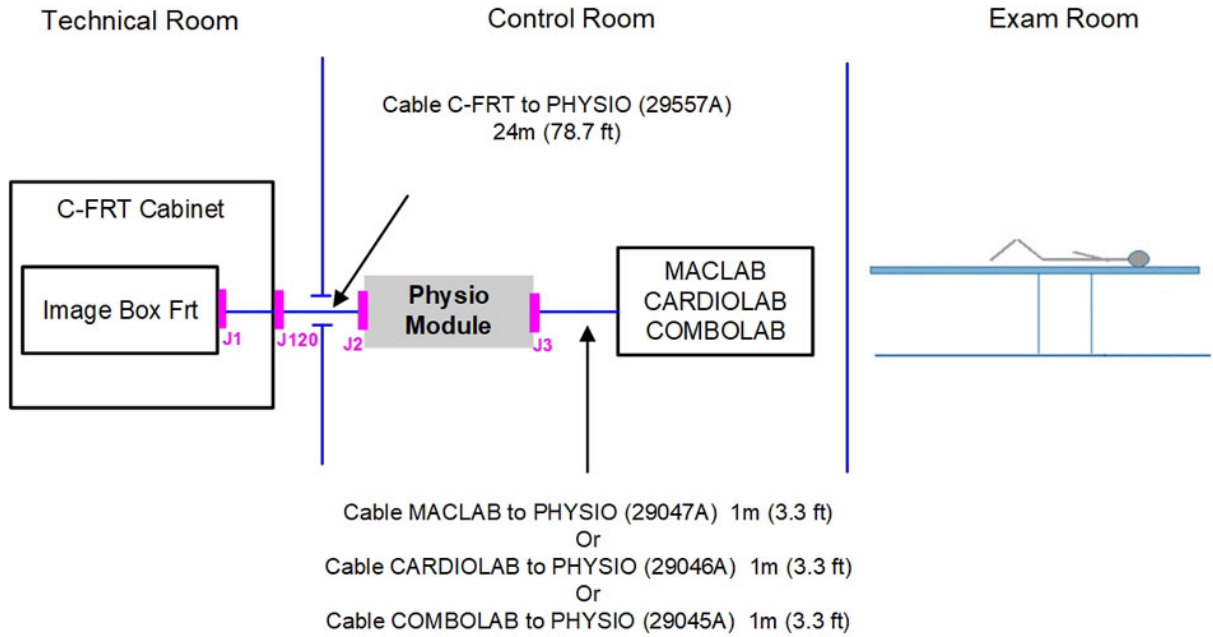
- 2018971-001 16CH ANALOG OUTPUT CPU INTERFACE OPTION
- 2007557-002 KIT ANALOG OUTPUT BOX W/CABLES
- 2010476-001 BOX CARDIOLAB/MACLAB ANALOG OUTPUT

### 2.2.2.4.1 ECG device in Control Room

Applicable to GE ECG device as MacLab, CardioLab or ComboLab.

In this configuration, the Physio module is installed in the Control Room.

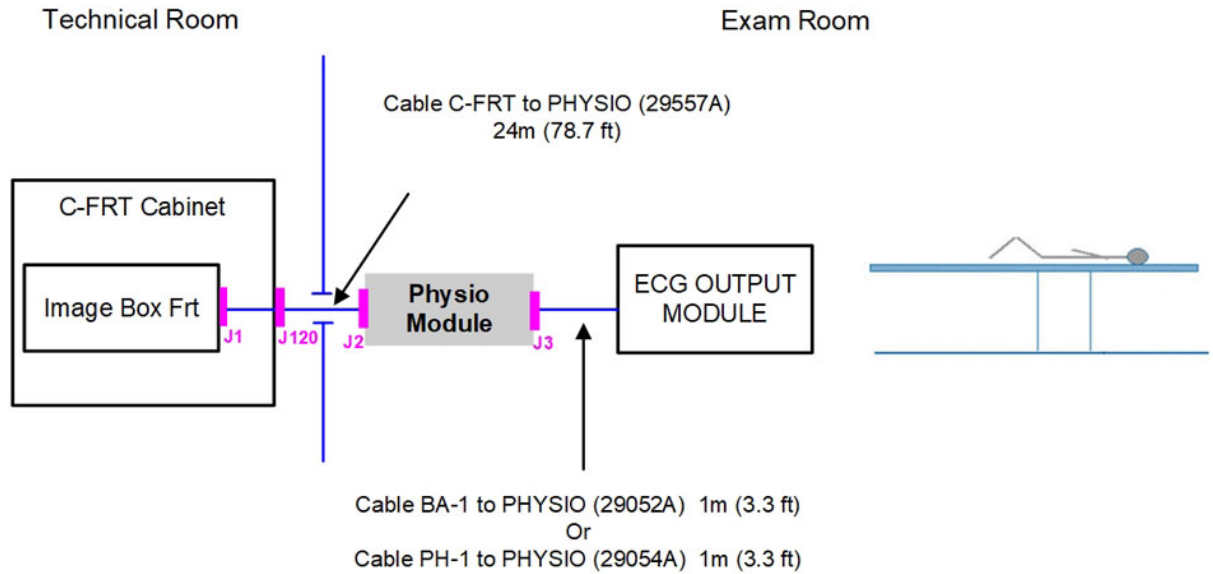
**Figure 2-75 ECG device in Control Room - Connection**



**2.2.2.4.2 ECG device in Exam Room**

In this configuration, the Physio module is in the Exam Room.

**Figure 2-76 ECG device in Exam Room - Connection**



**2.2.3 Room Layout Considerations**

**2.2.3.1 Clinical Access**

Make sure that you plan the room with the following clinical access requirements:

- Provide easy access to the patient table. Stretchers and other mobile hospital equipment must reach the table quickly.
- Minimum "trapping zone" safety clearance around the motorized moving parts of the System is 500 mm (19.7 in). Therefore, the minimum distance between the extreme positions of the

System, mainly gantry and Omega V/Innova IQ tables (or in case there is a table accessory, the extreme position of the accessory) and any static objects (e.g. wall) must be a minimum of 500 mm (19.7 in).

If room size does not allow 500 mm (19.7 in):

- The following text must be added on the room layout proposal reviewed and approved by customer (translated in customer local language):  
*"Note that your Allia IGS installation in the selected room does not meet the following minimal requirement: 500 mm (19.7 in) required distance between the System (precise which part) and any stationary object.  
  
Therefore the installer must apply a warning label in this area to remind the Operator about entrapment hazard during system motions."*
- In any case, table shall not collide with stationary object.
- A standard crushing label - Reference : ISO 7010 Crushing - W019 – must be applied in the area where the 500 mm (19.7 in) clearance is not met.
- Provide sufficient space around the patient table for the unimpeded conduct of CPR (Cardiac Pulmonary Resuscitation). With the table in this position, the table must be capable of rotating  $\pm 45^\circ$
- Clinicians at the patient table must be able to communicate with assistants in the control area.
- There must be an unrestricted view of the video monitors and physiological monitoring equipment from the vascular table. Refer to the section Equipment Requirements in the System Pre-Installation Manual.
- Operators in the control area must have easy access to the control console. However, position the controls (including handswitches) so that the operator cannot take exposures while looking around or standing outside the control booth's lead glass window.
- Operators in the control area must have easy access to video recorders, injector programmers, and service and operating manuals.
- Consult customer on the number and location of nonelectrical lines (air, oxygen, vacuum, water, etc.) in the vascular room.
- Make sure the backup monitors are easily accessible to view in case of failure of the LDM. For the systems where the backup monitors are mounted at the back of the LDM, plan a clearance so that the monitor can be flipped at 180°.

### 2.2.3.2 Peripheral Equipment

Consult hospital personnel regarding additional space requirements for the following types of hospital equipment:

- Sinks
- Oxygen stations
- IV apparatus
- Injectors
- Heart monitoring equipment
- Crash cart
- Ultrasound equipment.

### 2.2.3.3 Patient Environment Equipment

As defined in the IEC60601-1, the patient vicinity is defined as the space within the room 1.83 m (70.7") beyond the perimeter of the table and extending vertically 2.29 m (90.2") above the floor. Only the following components of the system can be installed within the patient vicinity:

- Table and its accessories
- Monitors
- Injector
- Rad-Shield
- User Interfaces

## 2.3 Room Structural Requirements

### 2.3.1 General Policy

#### 2.3.1.1 Baseplates Mounting

##### NOTICE

FLOOR, WALLS AND CEILING STRUCTURAL DESIGN THAT MEET MECHANICAL CONSTRAINTS OF SUPPORTING THE SYSTEM, FALL UNDER THE CUSTOMER'S RESPONSIBILITY.

**The customer is responsible for the structural analysis and mounting of the base plates. If GE HealthCare is forced to mount the base plate, the Local Customer Team must hire a structural engineer to design and approve the mounting method and provide GE HealthCare with an engineering report.**



##### NOTE

Any flooring material should be removed from the area where the LC Gantry base plate will be mounted. The grout must be directly applied to a properly primed surface, ensure no flooring material exists between the grout pad and the concrete floor. Remove all mastic as possible but do not use a solvent. Solvents prevent good bonding.



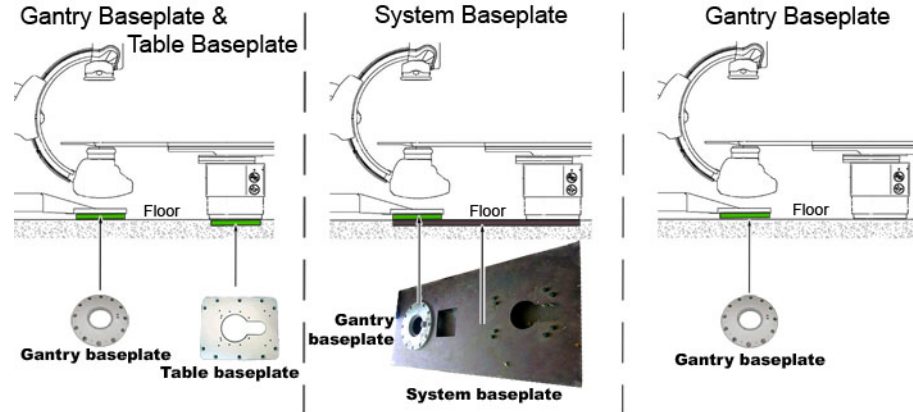
##### NOTE

If the floor is carpeted it must be cut and removed an additional 2 inches (51 mm) must be temporarily lifted out of the way all around if a dam is to be constructed.

**NOTICE**

The floor slabs on which the equipment is to be installed must have a levelness of 1 mm (0.04 in) per meter (40 in). Position of baseplates and table basement depends on the type of installation. The types of installation are given below.

**Figure 2-77 Types of baseplate installation**



**NOTICE**

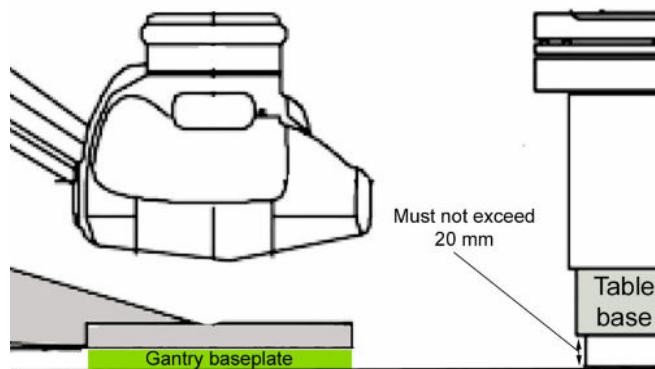
The Table baseplate or the System baseplate are mandatory to install the Innova<sup>IQ</sup> Table.

The Innova<sup>IQ</sup> Table must never be installed on grade.

**NOTICE**

The gap between the Table Foot bottom end the Gantry Baseplate bottom end shall be lower than 20 mm (0.97 in). Any bigger gap would make the system incompatible with the Vision Applications.

Gap between Table Foot bottom end the Gantry Baseplate bottom

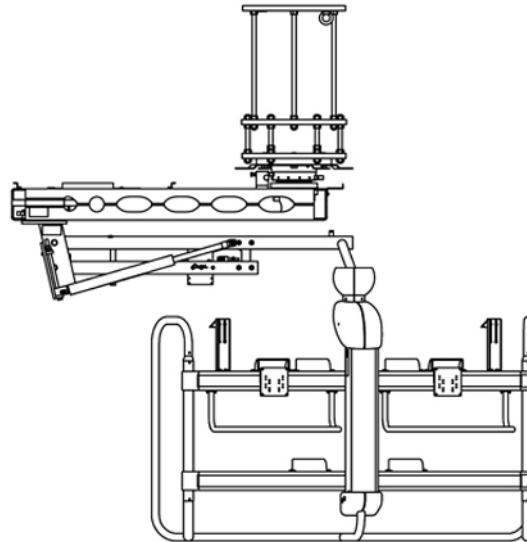


The preferred installation method for the LC Positioner or the Omega tables is through-bolting. The through-bolting method can be used in all seismic zones. If through-bolting cannot be used, use provided floor anchors instead.

### 2.3.1.2 Substructure for Dual Arm suspension Mounting (for Mavig suspension with fixed point dual arm)

The customer is responsible for the structural analysis and mounting of the Substructure for Dual Arm suspension in the solid ceiling (in case of a MAVIG suspension with fixed point dual arm). If customer requires GE HealthCare to mount the Substructure for Dual Arm suspension, the customer must hire a structural engineer to design and approve the mounting method and provide GE HealthCare with an engineering report.

**Figure 2-78 Medium Height Substructure for Dual Arm Suspension and MAVIG Suspension with Fixed Point Dual Arm for Large Display Monitor**



#### NOTICE

The Substructure for Dual Arm suspension is mandatory to install the MAVIG suspension with fixed point dual arm.

#### NOTICE

The lower edge of the Substructure for Dual Arm suspension should be the same height as the lower edge of the false ceiling.

## 2.3.2 Floor Requirements

### 2.3.2.1 Floor requirements when using provided floor anchors

The maximum pullout force per provided anchor was calculated assuming:

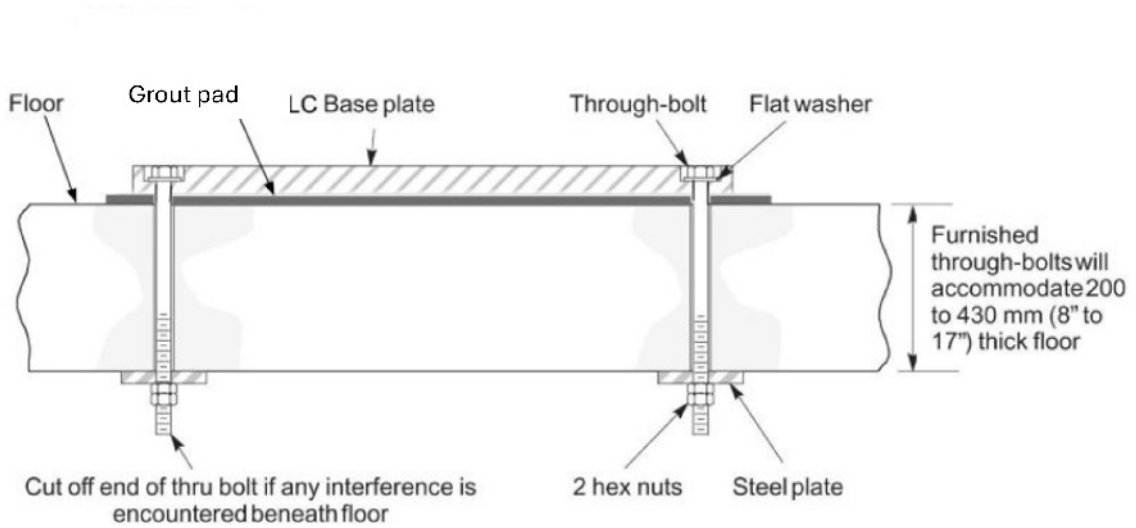
- A concrete compression strength of **17.24 MPa** at 28 days (which is the minimum required compression strength).
- Anchors installed to the required hole depth of **165.1 mm** minimum, and
- Center of anchor hole to concrete edge distance **79.4 mm**.

Make sure to obtain data on compression strength of the concrete before using floor anchors.

### 2.3.2.2 Floor Construction Requirement

For Slab Type Floor construction, see [Figure 2-79 Through-Bolt Supplied \(Slab Type Floor construction\)](#) on page 115.

**Figure 2-79 Through-Bolt Supplied (Slab Type Floor construction)**

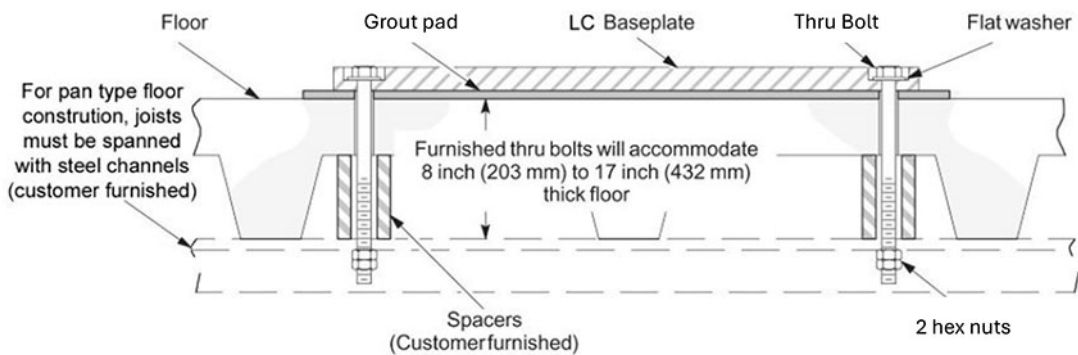


**NOTE**

For specific floor preparation procedures, refer to *Pre-Installation Kit Installation Procedures* - P/N 5985495-199.

For Pan type floor construction, steel channels must be designed by a local structural engineer to span floor joists. See [Figure 2-80 Through-Bolt Supplied \(Pan Type Floor Construction\)](#) on page 115.

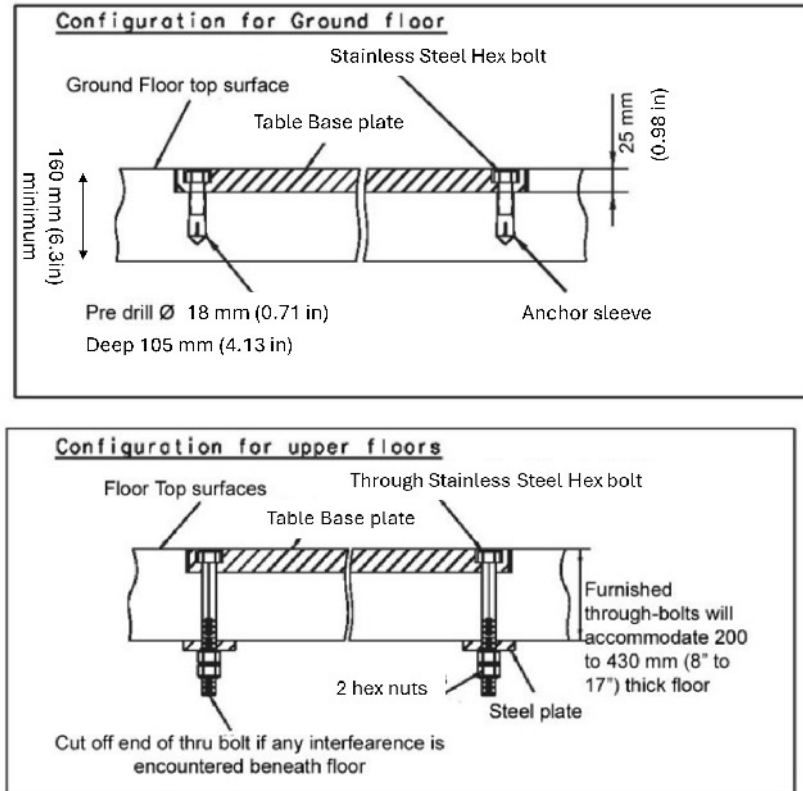
**Figure 2-80 Through-Bolt Supplied (Pan Type Floor Construction)**



**NOTE**

For detailed information, refer to *Pre-Installation Kit Installation Procedures* - P/N 5985495-199.

Figure 2-81 Table floor mounting layout



**NOTE**

For detailed information, refer to *Pre-Installation Kit Installation Procedures - P/N 5985495-199*.

**NOTICE**

Prepare the floor such that the table base plate will be flush with the floor finish surface, considering the thickness of the floor finish material.

For alternative table bolts or seismic area, refer to template drawing shown in *Illustration LC Positioner And Table Floor Mounting Template* contained in [2.3.3 Mounting Requirements on page 120](#).

**2.3.2.3 Hole dimension and preferred location in concrete floor**

In the Exam Room, the LC Positioner is not placed on a computer floor but directly put on concrete floor, the location of the cable access needs to be carefully planned.

Otherwise, if the cable run is located under the concrete floor, the cables will have to come through the floor and in this case you will need two holes, one for the LC Positioner and the other for the patient table.

The diameter of both holes is specified in [Figure 2-82 Hole location in concrete floor on page 117](#).

Figure 2-82 Hole location in concrete floor

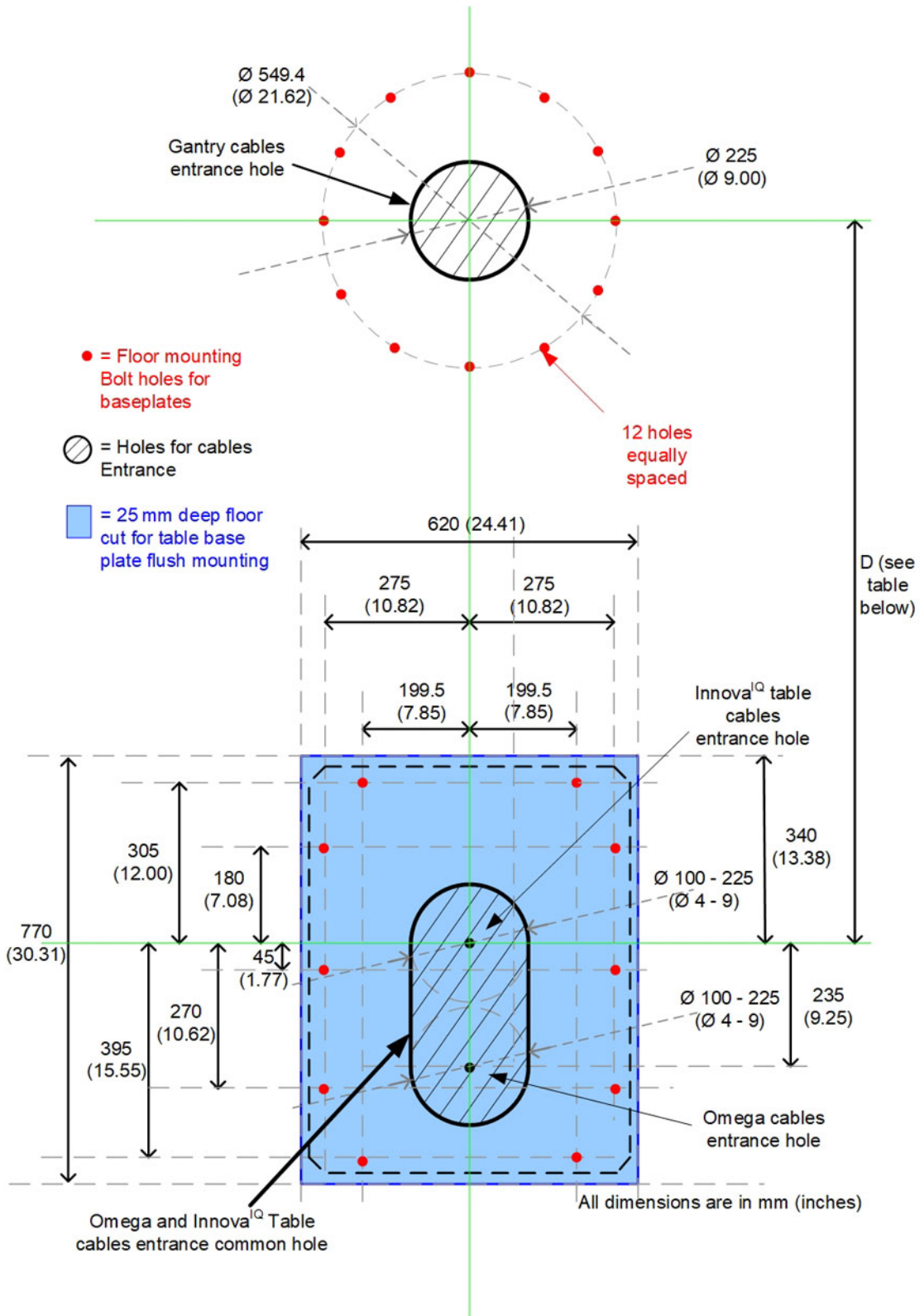


Table 2-11 D distance

	ANGIO mm (in)	CARDIO mm (in)	NEURO mm (in)
Omega IV Compact Table	Not applicable	1395 (54.9)	Not applicable
Omega V Long Table	1278 (50.3)	1395 (54.9)	1395 (54,9)

**Table 2-11 D distance** (Table continued)

	<b>ANGIO</b> mm (in)	<b>CARDIO</b> mm (in)	<b>NEURO</b> mm (in)
Innova <sup>IQ</sup> Table	1278 (50.3)	1395 (54.9)	1395 (54,9)

**NOTICE**

Due to the plastic bushing used in the USA to protect cables from the sharp edges of conduits it is necessary to place the cable conduit inside the table cable access opening but the height of the outcoming conduit plus bushing is limited to 1/2 in (12.7 mm).

**NOTE**

Refer to table *Chemical anchors Pull out efforts and recommendations* in [2.3.3 Mounting Requirements on page 120](#) for pull out effort on each fixation bolts.

**2.3.2.4 Water Pipes and Oil Hoses Requirements**

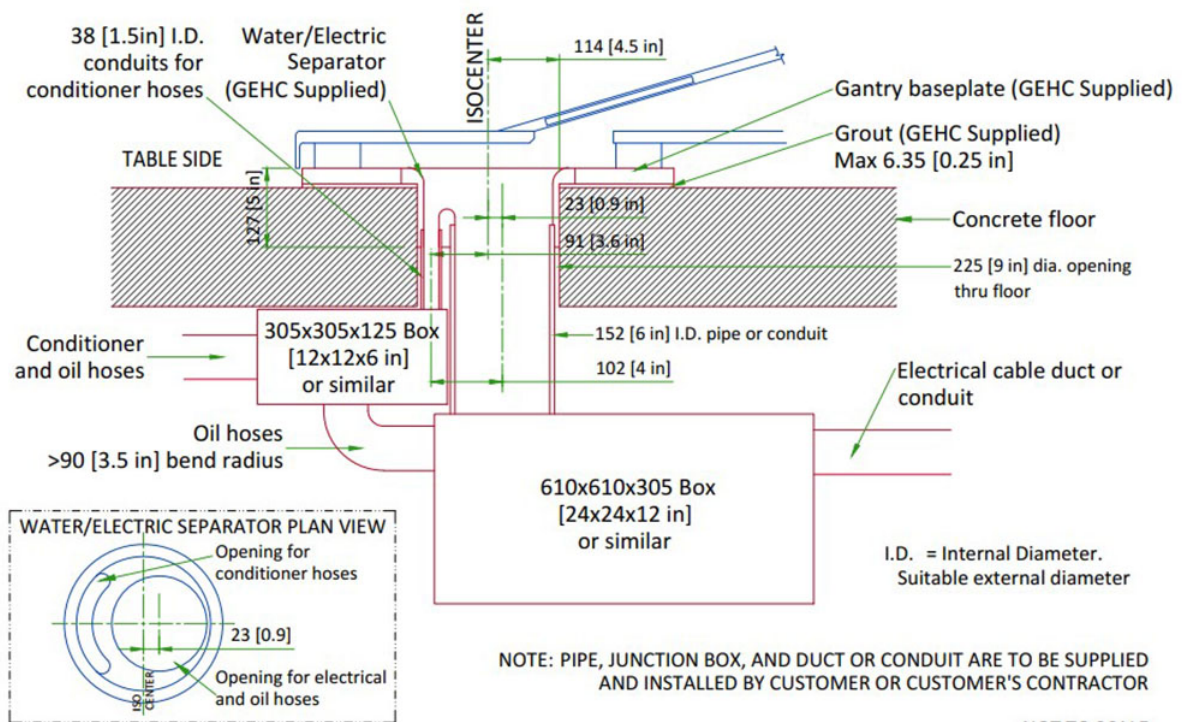
The system uses oil hoses for the X-Ray Tube cooling and water pipes for the Detector cooling. Local regulation may require that electrical cables, water pipes and oil hoses are ran in separate conduits from the Detector Chiller and Tube Cooling Unit to the Gantry.

The oil hoses minimum bending radius is 90 mm.

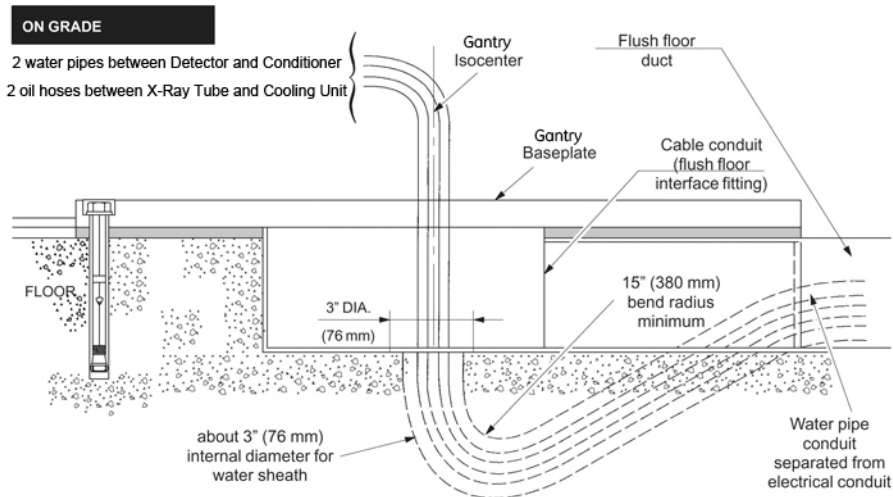
The oil hoses shall be in a 10°C to 35°C environment.

Heat dissipation through the oil hoses will depend on their environment. It is expected that the most the hoses are insulated, the most heat will dissipate through the cooling unit. Hence, the customer site install may influence the cooling performance of the entire cooler, and thus oil temperatures.

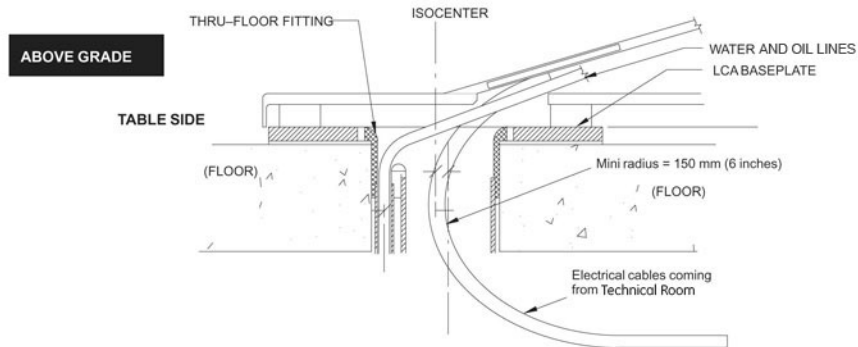
**Figure 2-83 Water and Oil Conduit location with “Above Grade” anchor kits**



**Figure 2-84 Water and oil Conduit location with “On Grade” anchor kits**

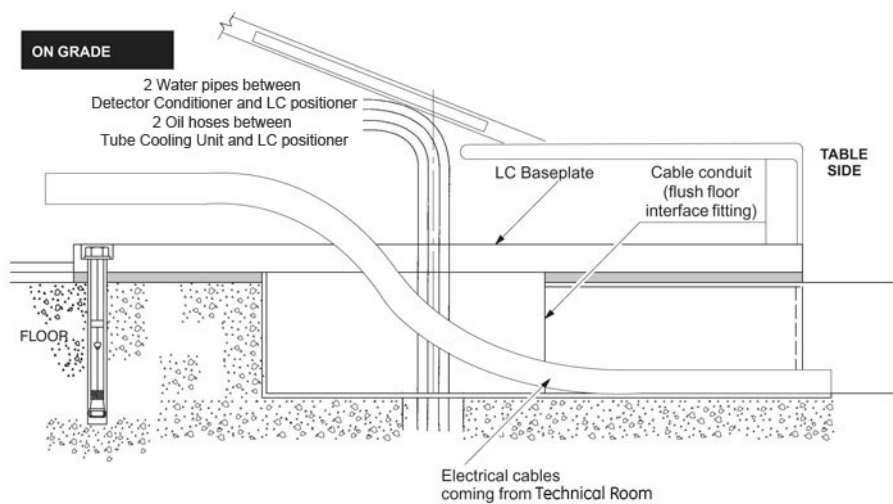


**Figure 2-85 Cable Curvature with “Above Grade” anchor kits**



**Note:** In case of thru-floor cabling, if the electrical cables are coming from the head side, they will need to have a minimum curvature with a minimum radius of 150 mm (6”). In any other cases (i.e. flush floor) no such curvature is allowed.

**Figure 2-86 Cable Curvature with “On Grade” anchor kits**



**NOTE**

In case of on grade cabling, because of the minimum curvature constraint of 150 mm (6”), the cable will have to come from the side between the Gantry and the Patient Table.

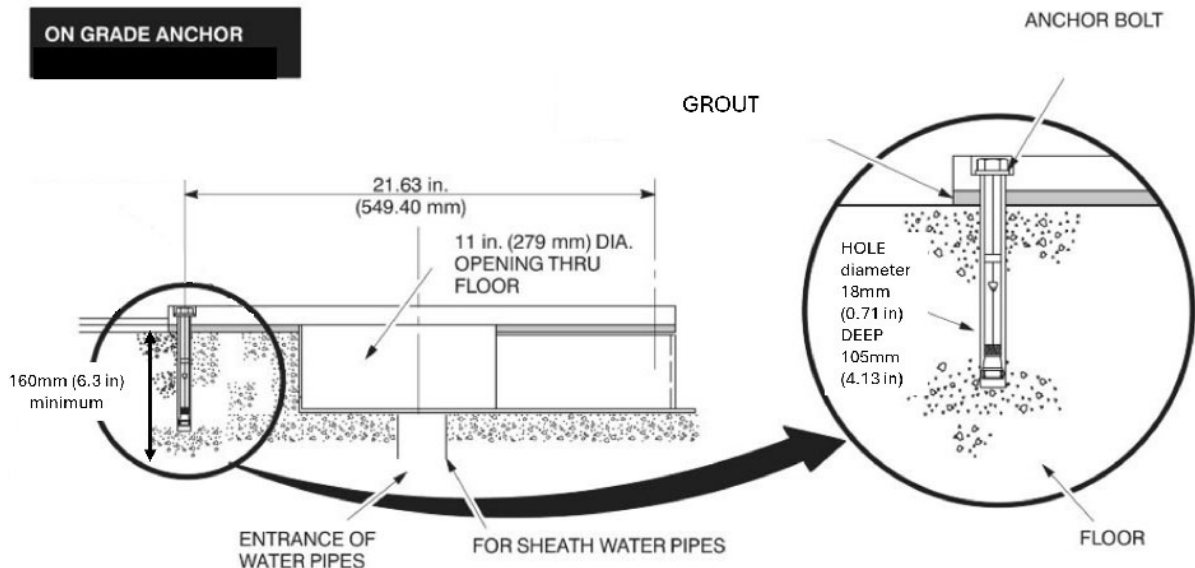
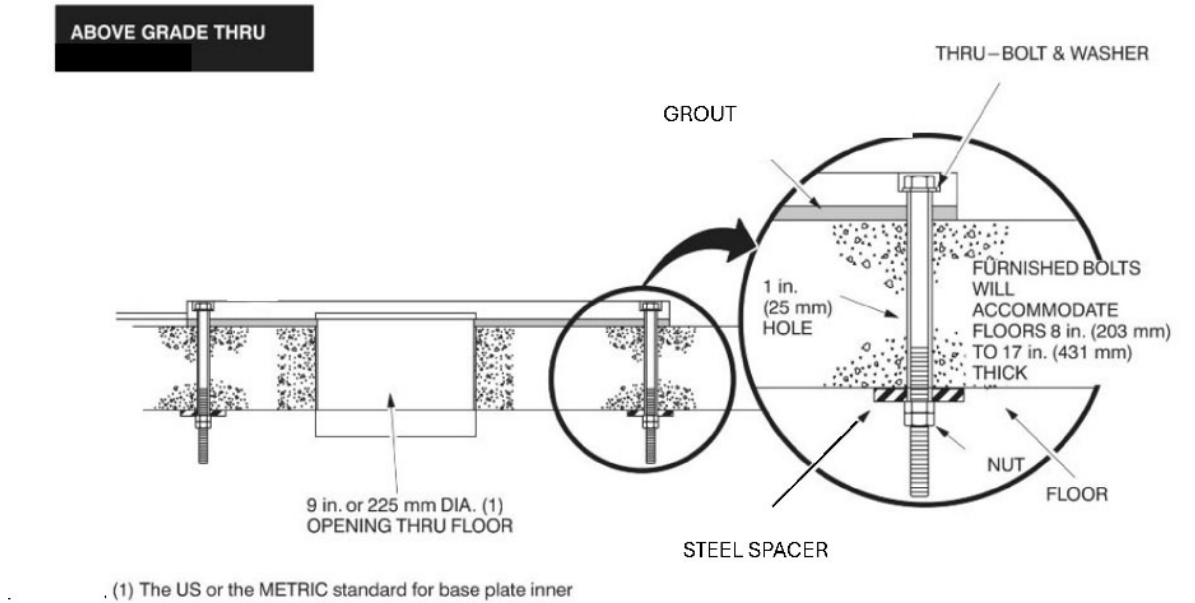
## 2.3.3 Mounting Requirements

### 2.3.3.1 Positioner and Table Floor Mounting

The distances between the Gantry and the Tables are critical for a proper clinical usage. For this reason, GE HealthCare provides two floor mounting templates to ensure these components are properly placed in relation to one another.

Procedures to secure Gantry and Table Floor Mounting Methods are described in *Pre-Installation Kit Installation Procedures* - P/N 5985495-199.

Figure 2-87 Gantry Floor Mounting Methods (1/2)



Procedures to secure Gantry and Table Floor Mounting Methods are described in *Pre-Installation Kit Installation Procedures* - P/N 5985495-199.

Figure 2-88 Gantry Floor Mounting Methods (2/2)

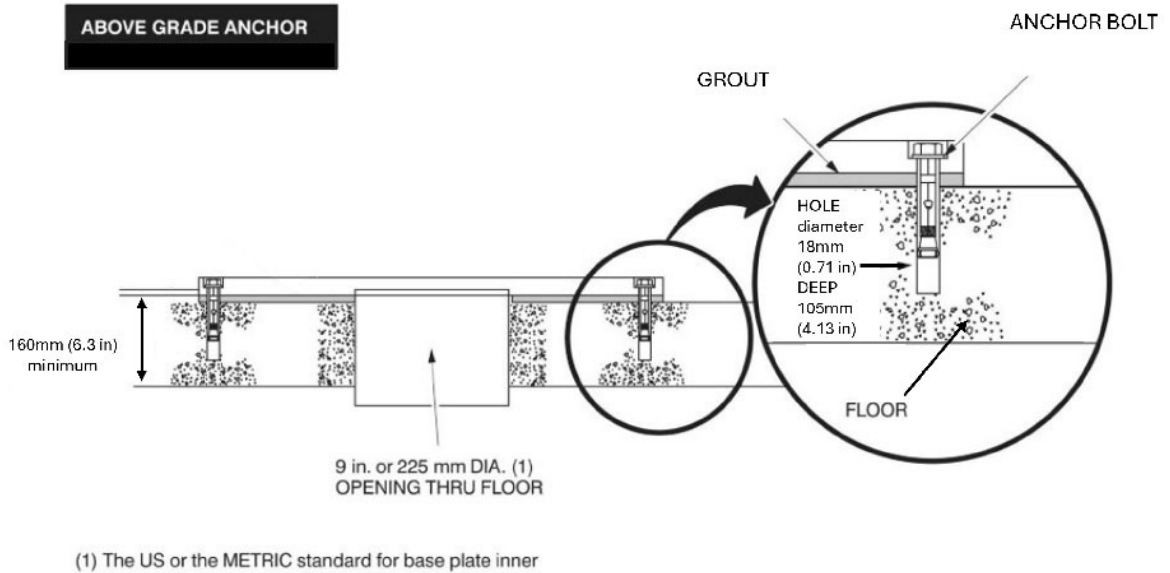
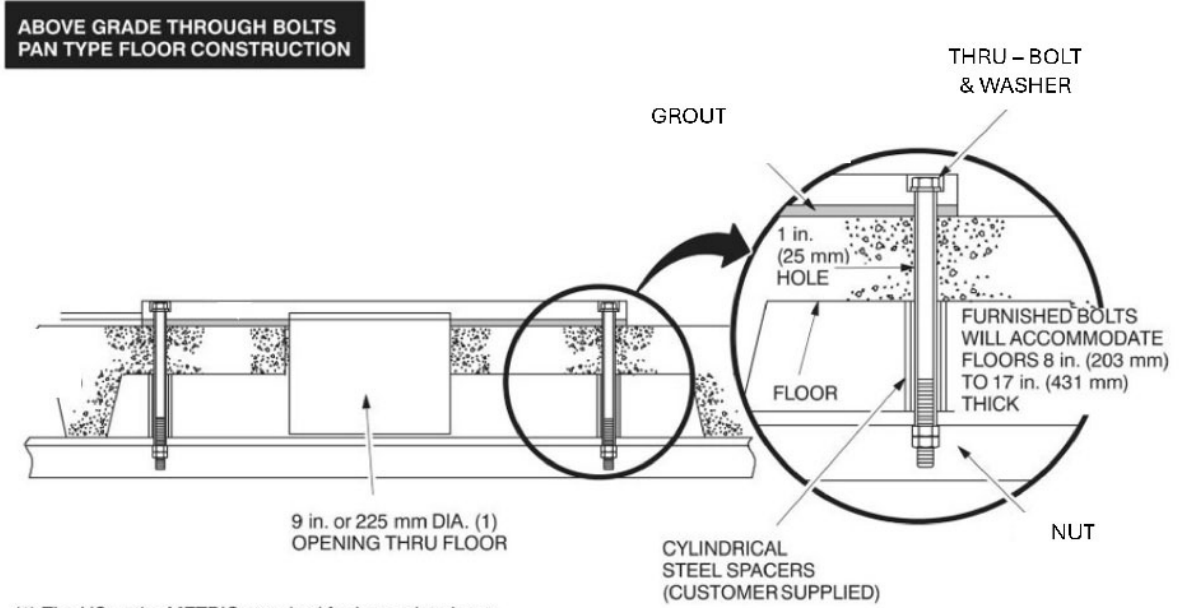
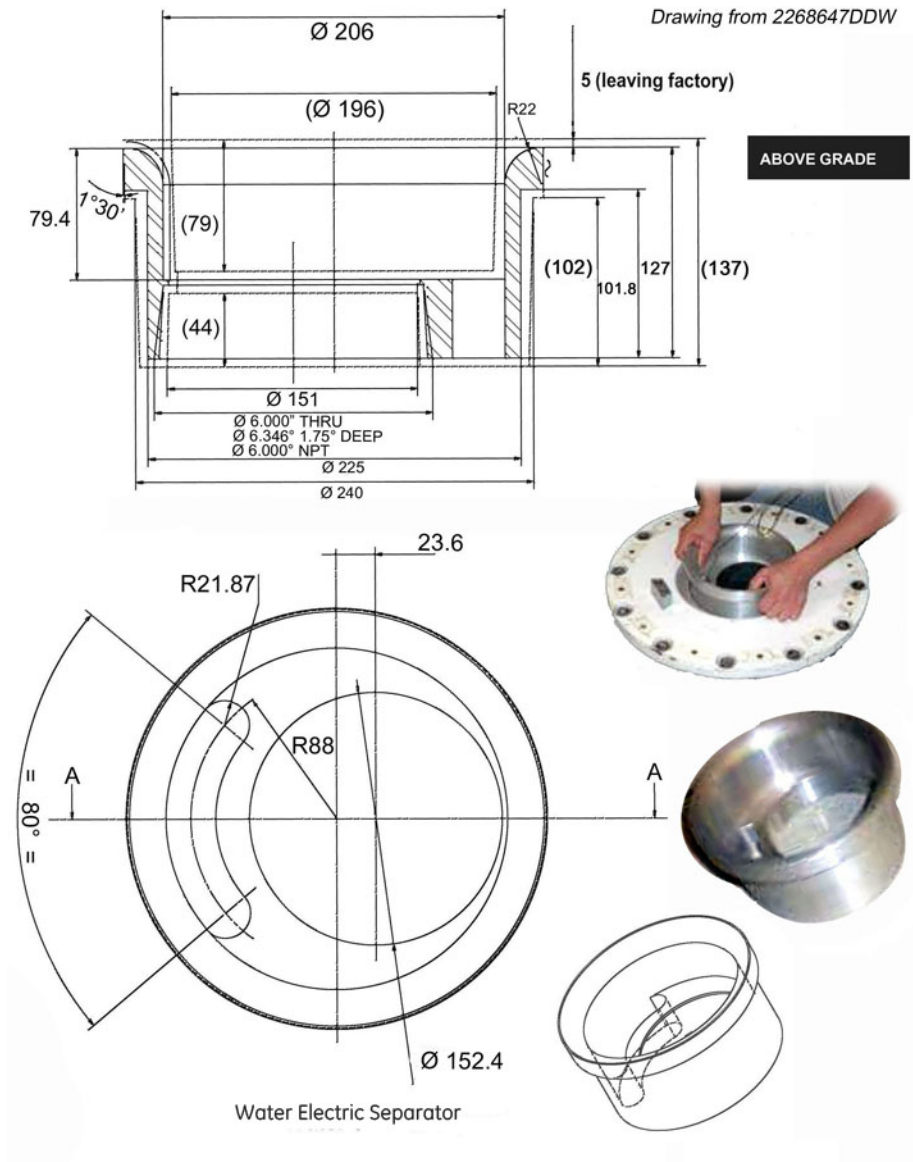


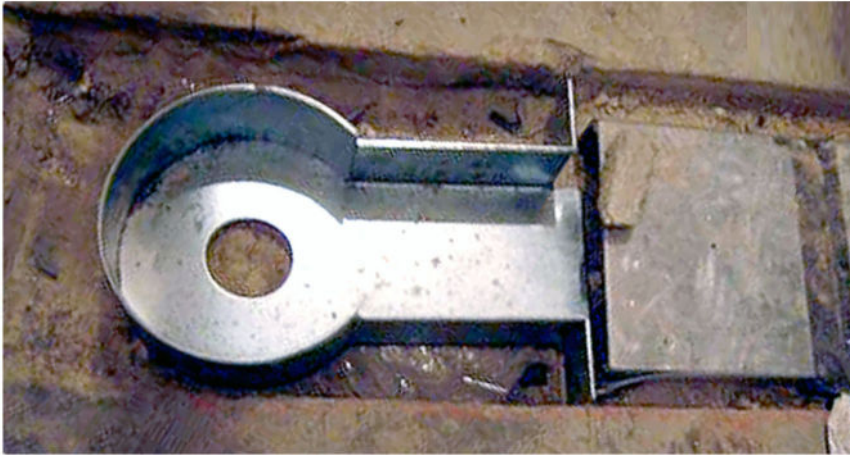
Figure 2-89 Inner Base Plate (Water Electric Separator) for Above Grade Floor Anchor Kit



**NOTE**  
Part available depending on the country.

**NOTE**  
Dielectric oil hoses don't need to be separated from electric cables.

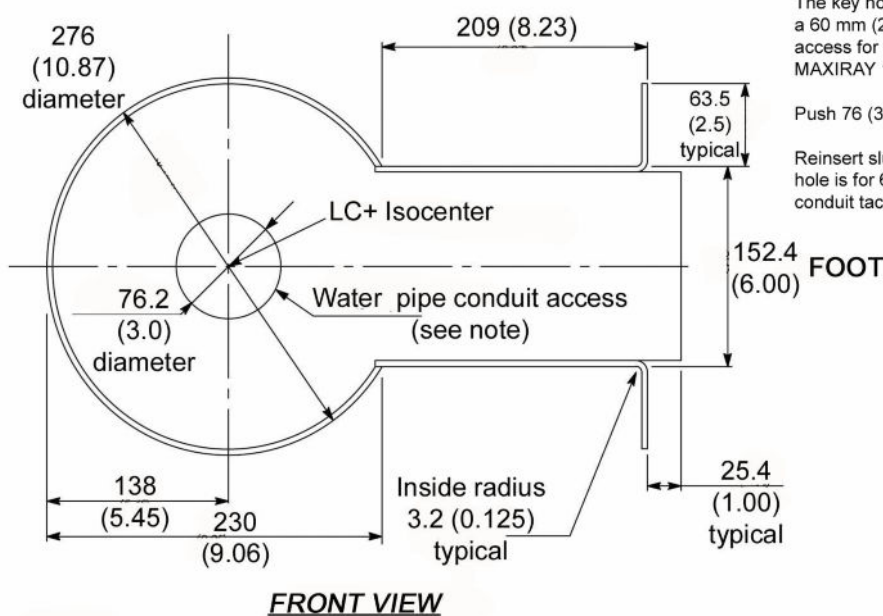
**Figure 2-90 Cable Conduit For On-Grade Floor Anchor Kit**



Dimensions in mm (inches)

**ON GRADE**

**2**  
Equipment Requirements

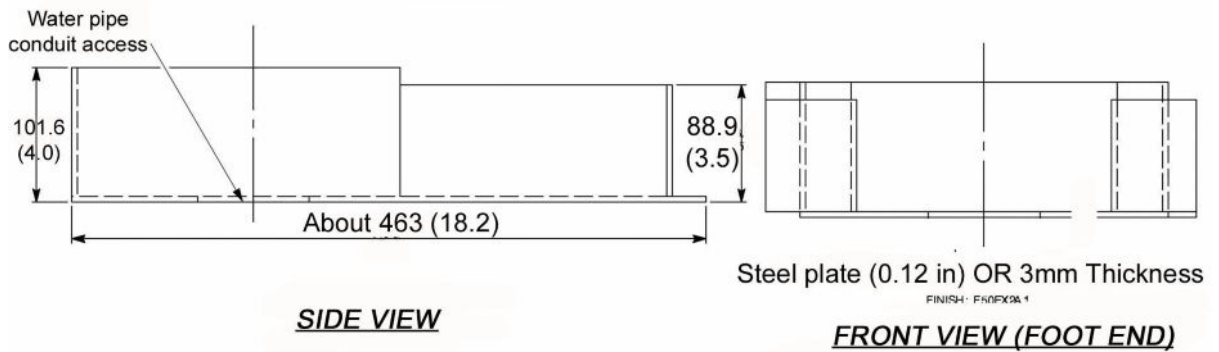


The key hole has been redesigned to permit a 60 mm (2.5 in.) water conduit to separate access for waterpipes used with a MAXIRAY 150.

Push 76 (3.0) hole in center.

Reinsert slug and tack well in one spot hole is for 63.5 (2.5) internal diameter conduit tack well from bottom if possible.

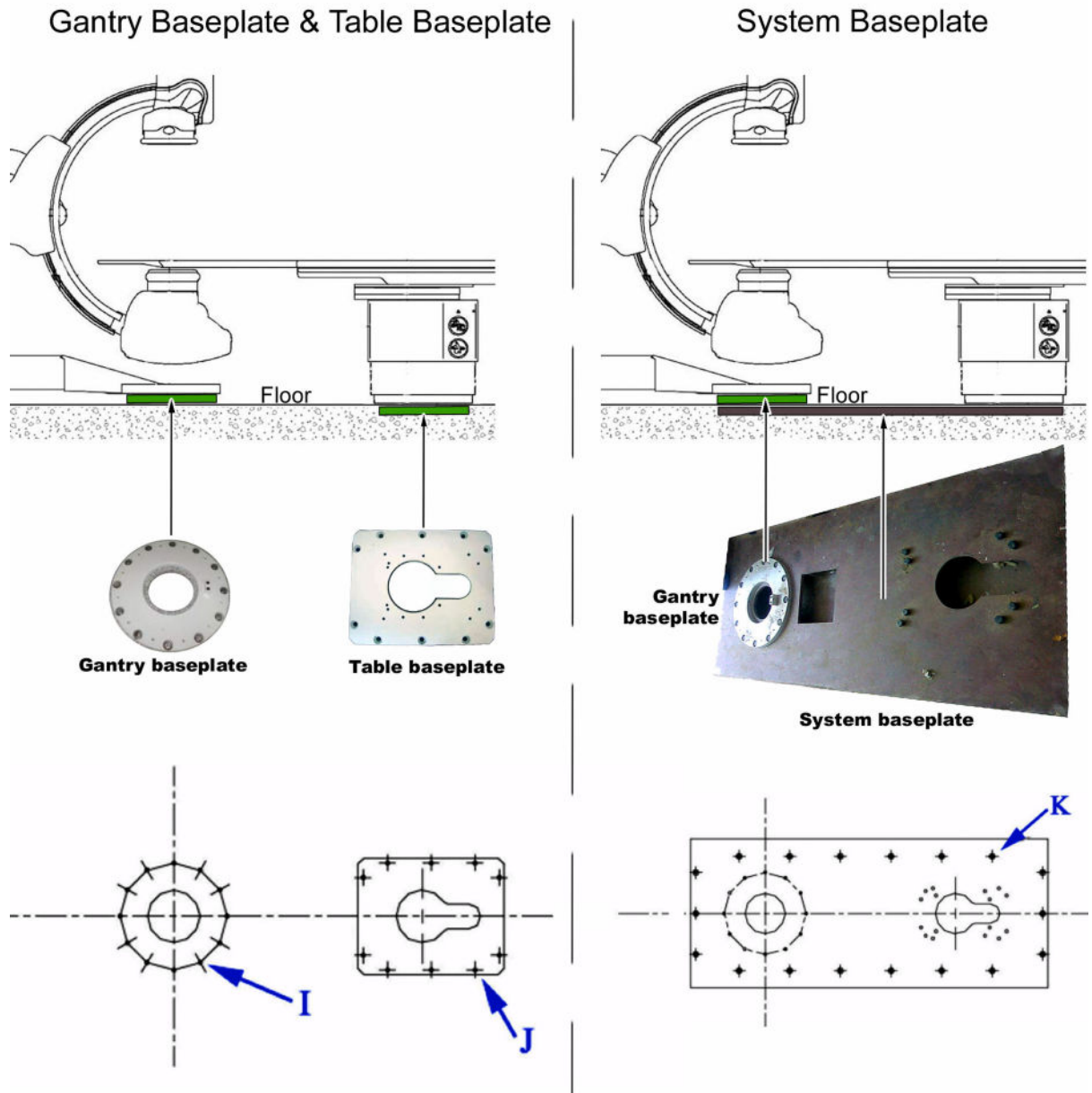
**FRONT VIEW**



**SIDE VIEW**

**FRONT VIEW (FOOT END)**

**Figure 2-91 Fixing Bolt Overview**



**NOTE** For more details on Floor plate or Base plates, refer to [Figure 2-92 Gantry and table mounting holes](#) on page 126 and illustration *Hole location in concrete floor* in [2.3.2 Floor Requirements](#) on page 114.

- NOTE**
- With any kind of fixation methods (Bolts M20, Mechanical anchors or Chemical anchors), the mandatory number of holes used is:
    - Gantry base plate : 12 max and 8 min holes used are acceptable.
    - Table base plate : 10 max and 8 min holes used are acceptable.
 We CANNOT have 2 consecutive holes omitted.
  - Dedicated to Floor base plate, fixation method is only Chemical anchors. The mandatory number of holes used is 22 max and 12 min holes used are acceptable. We can have only 2 consecutive holes omitted.



**NOTE**

In case of floor plate configuration, the gantry base plate shall be mounted onto the floor plate, but the table base plate shall not be mounted on the floor plate.

**Pull out efforts and recommendations about chemical anchors not provided by GE.**

The following table provides the recommended chemical anchors for Table/Gantry base plates and for the floor plate ordered locally that they could be used instead of bolts provided by GE.

**Table 2-12 Chemical anchors Pull out efforts and recommendations**

	<b>Gantry Base Plate</b>	<b>Table Base Plate</b>	<b>Floor Plate (to be ordered locally)</b>	<b>Table Omega</b>
Mark	<b>I</b> on Figure 2-91 Fixing Bolt Overview on page 124	<b>J</b> on Figure 2-91 Fixing Bolt Overview on page 124	<b>K</b> on Figure 2-91 Fixing Bolt Overview on page 124	<b>A</b> on Figure 2-92 Gantry and table mounting holes on page 126
Pull out effort	736 daN per bolt if 12 used and 1992 daN per bolt if 8 used	1120 daN per bolt if 10 used and 2000 daN per bolt if 8 used	272 daN per bolt if 24 used and 2008 daN per bolt if 12 used	4432 daN per bolt with 4 bolts
Number of holes in the plate	12 max (8 min mandatory)	10 max (8 min mandatory)	24 max (12 min mandatory)	4 mandatory
Recommended chemical anchors example 1	Supplier HILTIHVU adhesive capsule + HAS Anchor rod	Supplier HILTIHVU adhesive capsule + HAS Anchor rod	Supplier HILTIHVU adhesive capsule + HAS Anchor rod	Supplier HILTIHVU adhesive capsule + HAS Anchor rod
Threaded rod	M16 A4-70 / 333 131 5/8	M20 A4-70 / 333 135 3/4	M16 A4-70 / 333 131 5/8	M20 A4-70 / 333 135 3/4
Hole diameter in the floor	18 mm (11/16 in)	24 mm (7/8 in)	18 mm (11/16) in	24 mm (7/8 in)
Hole depth in the floor	125 mm (5 in)	170 mm (6-5/8 in)	125 mm (5 in)	170 mm (6-5/8 in)
Minimum floor thickness	180 mm (7 in)	220 mm (8-1/2 in)	180 mm (7 in)	220 mm (8-1/2 in)
Max Tightening Torque	80 N.m (59 ft-lb)	150 N.m (110 ft-lb)	80 N.m (59 ft-lb)	150 N.m (110 ft-lb)



**NOTE**

The floor plate ordered locally needs to be in steel.

Refer to supplier technical documents for all specification and installation data about chemical anchors.

Figure 2-92 Gantry and table mounting holes

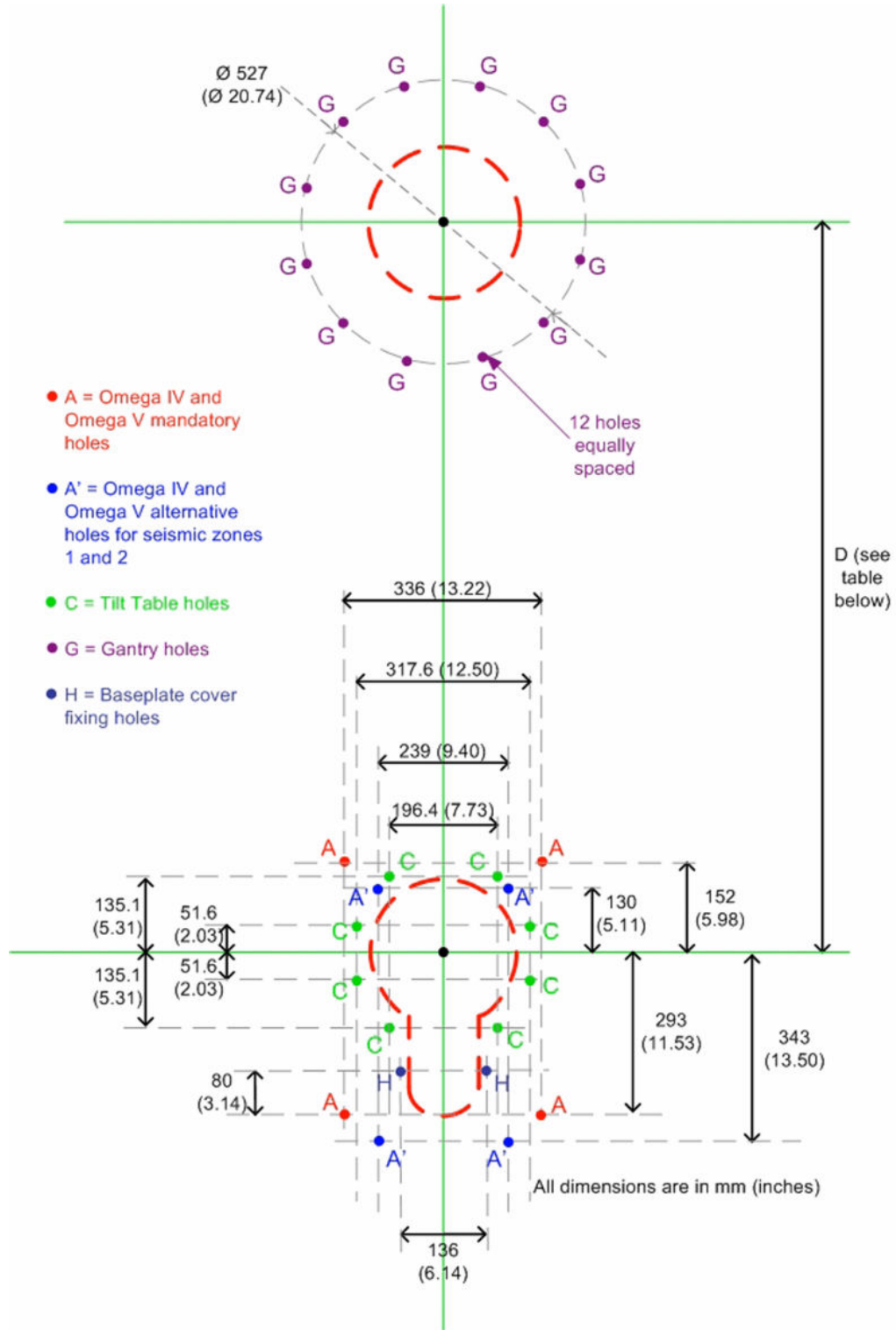


Table 2-13 D distance

	ANGIO mm (in)	CARDIO mm (in)	NEURO mm (in)
Omega IV Compact Table	Not applicable	1395 (54.9)	Not applicable
Omega V Long Table	1278 (50.3)	1395 (54.9)	1395 (54.9)
Innova <sup>IQ</sup> Table	1278 (50.3)	1395 (54.9)	1395 (54.9)

### 2.3.3.2 Gantry Table Floor Preparation Kits (GE supplied)

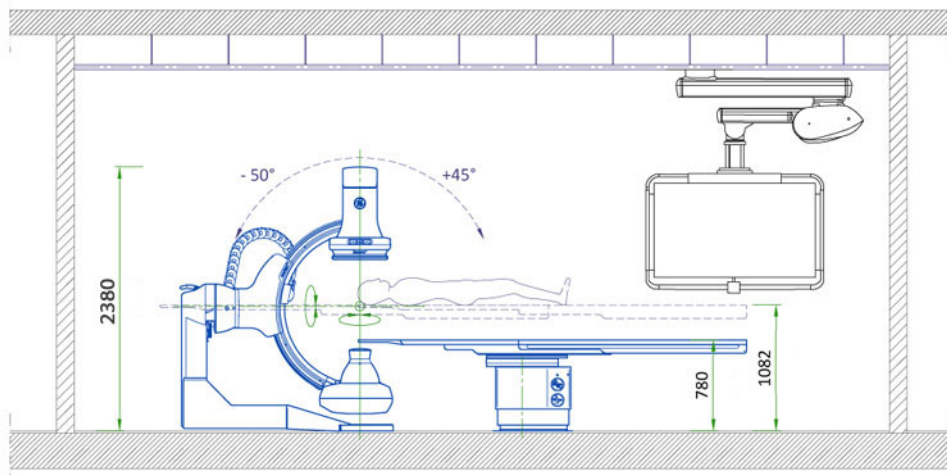
Refer to *Floor Pre-Installation Kit Procedures* - P/N 5985495-199.

## 2.3.4 Ceiling Requirements

### 2.3.4.1 Third Party Monitor suspension (option)

Attention must be paid to the height of suspended elements of the third party monitor suspension, collision must be avoided with the gantry.

**Figure 2-93 Gantry and Third Party Monitor Suspension**



Dimension in mm

### 2.3.4.2 Mavig suspension with rails

Aluminum rails support the In-Room Monitor bridge used in the system X-Ray rooms.

When evaluating ceiling you must take into account the mounting information below.

#### 2.3.4.2.1 Rail Mounting

Attach stationary rails to structural steel with through-bolts in concrete ceilings. Do not use screw anchors in direct tension.

Mount stationary rails directly to the ceiling slab or to flush-mounted unistrut or halfen structure. In higher rooms with false ceiling, mount stationary rails to rigid vertical members hung from ceiling slab.

Securing a supplementary channel to the bottom of the vertical members and mounting the stationary rails to this channel can greatly reduce the number of vertical members.

The stationary rail support structure must be leveled before installation can begin. Do not assume that any support structure is level within specified tolerances, particularly after removing suspensions from an existing room.

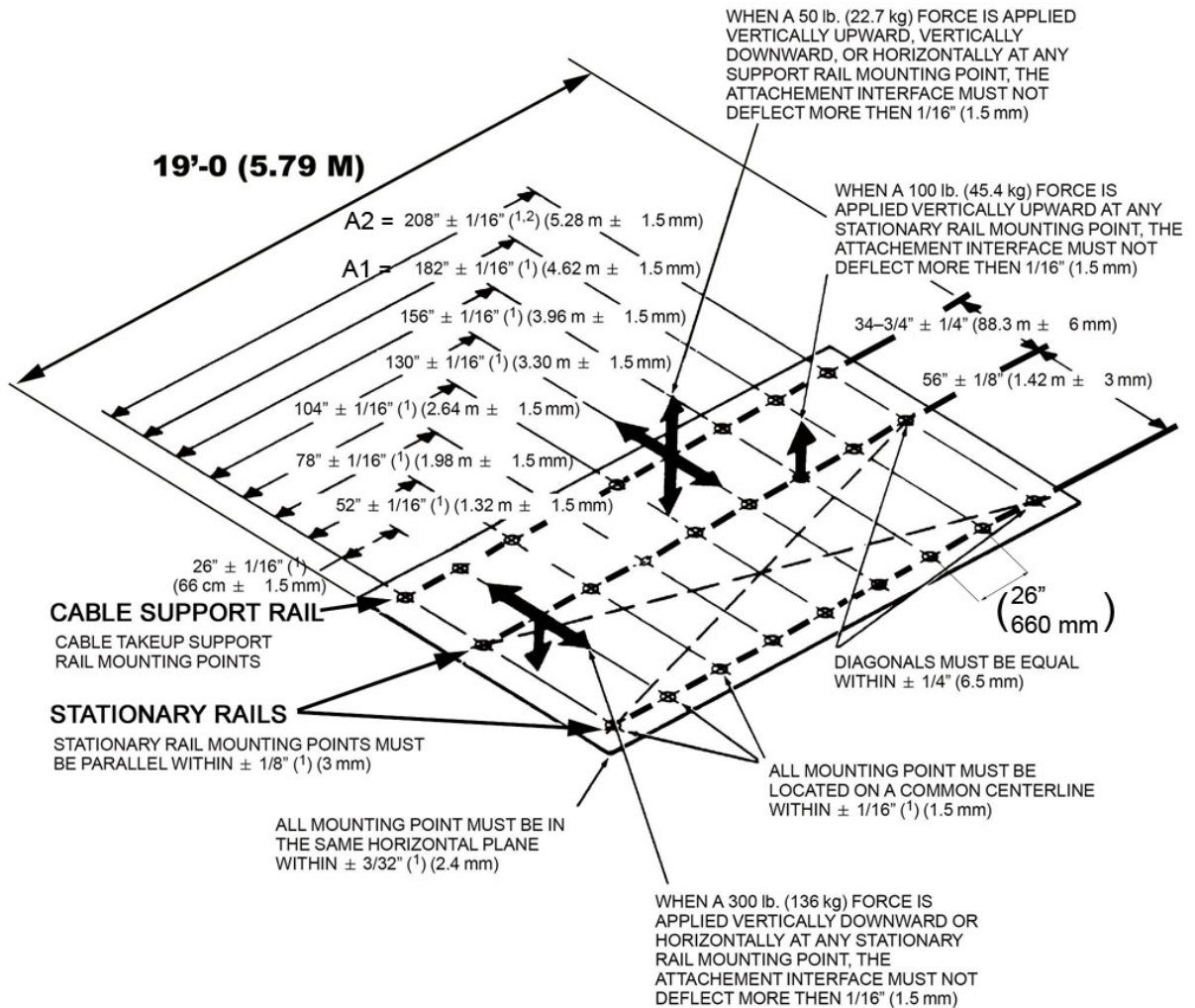
#### 2.3.4.2.2 Bolt Specifications (Mavig suspensions)

- The maximum load per bolt will not exceed **1557 N (350 lbs)**.
- Each bolt must not “pull out” or otherwise fail under a vertically downward *dead* load of **6228 N (1400 lbs)**.

### 2.3.4.2.3 Select Rails (Mavig suspensions)

Monitor suspension rails in two lengths can be selected. Please refer to the Selectable item process or contact the GE representative.

**Figure 2-94 Specifications for a typical 19'-0 (5.79 m) inboard stationary rail mounting interface (both rails ceiling mounted), for Mavig suspension**



NOTES: 1. NONE CUMULATIVE ERROR.  
2. SPACE BETWEEN LAST 2 HOLES MAY BE LESS THAN 26" (66 cm)

**Table 2-14 Stationary rail in different length**

Rail length cm (in)	Number of holes	A	INBOARD RAILS
472 (186")	8	A1: 7 x 66 cm = 462 cm 7 x 26" = 182"	S18121RC
579 (228")	9	A2: 8 x 66 cm = 528 cm 8 x 26" = 208"	S18121RA

### 2.3.4.2.4 Cable Support for Monitor Cables

The rails & cable drape are provided with the system, except for the USA, where the Cable Support Kit must be provided locally by the Customer (e.g. CPGE55 from Unistrut).

### 2.3.4.3 MAVIG suspension with fixed point dual arm

The Substructure for Dual Arm suspension is used to attach the MAVIG suspension with fixed point dual arm to the solid ceiling. It is used as the bridging element between the solid ceiling and the false ceiling for the installation and the fixation of the suspension.

Also, it provides a hooking point required for the installation and the replacement of the Large Display Monitor.

The Substructure for Dual Arm suspension is mandatory to install the MAVIG suspension with fixed point dual arm for Non-seismic Zones. For Seismic Zone installations, refer to Structural Engineer for appropriate design of the structure for installing the MAVIG suspension system.

For standard site configurations, the distance between the ceiling and the lower edge of the false ceiling should be in a range of minimum 175 mm and maximum 610 mm.

**NOTICE**

If the distance between the ceiling and the lower edge of the false ceiling is more than 610 mm, Long variation of the Substructure for Dual Arm suspension solution could be proposed by MAVIG.

If the distance between the ceiling and the false ceiling is less than 175 mm, then the middle plate is not installed. Refer to [Table 2-15 on page 129](#).

**Table 2-15**

Distance between ceiling and false ceiling	Configuration of the Substructure for Dual Arm suspension	Item and Description
Minimum is 175 mm and maximum is 610 mm		<p>[1]: Weight in kg                  [2]: Ceiling Plate                  [3]: Middle Plate                  [4]: Maximum is 155 mm</p>
Less than 175 mm		<p>[5]: Maximum is 175 mm / Minimum is 145 mm</p>



**NOTE**

When distance between ceiling and false ceiling is less than 175 mm, 145 mm minimum is to secure the insertion of the video connection plate delivered with MAVIG Dual Arm suspension.

The Substructure for Dual Arm suspension is delivered with each system. In the GE HealthCare system catalogue (Pre-Installation item), its purchase number is S18391MX (MAVIG Purchase number GD60D022).

### 2.3.4.3.1 Substructure for Dual Arm suspension mounting

The length of the Substructure for Dual Arm suspension S18391MX can be adapted to any individual situation (distance between solid ceiling and the lower edge of the false ceiling).

Length calculation and adaptation instruction are provided in the MAVIG substructure assembly instructions DBF0100X (where X may be 1 or higher).

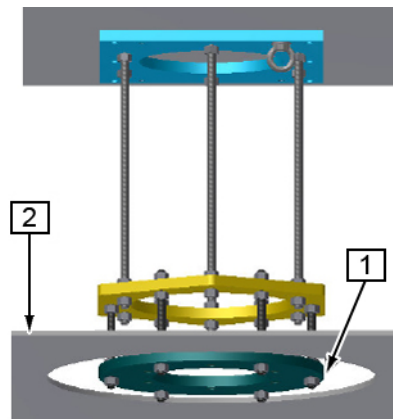
The Substructure for Dual Arm suspension must be fastened to the ceiling using six suitable screws.

These screws must be dimensioned according to the conditions of the ceiling and provided by the customer and must be checked by the structural engineer.

The ceiling plate (Figure 2-51 Ceiling Plate of Substructure for Dual Arm suspension - Dimensions on page 90) must be seated flush to the ceiling in order to ensure optimum load distribution.

The lower edge of the Substructure for Dual Arm suspension (Interface plate [1]) should be the same as the height as the lower edge of the false ceiling [2].

**Figure 2-95 False ceiling alignment versus interface plate**



### 2.3.4.3.2 Bolt Specifications

The statics of the ceiling structure must be designed for safe, load bearing and transfer of the ceiling substructure with suspension arm system and attached devices plus any other existing load applied to the ceiling. In all cases a civil or structural engineer must be consulted.

The screws used to attach the system to the ceiling are not part of the system.

The Substructure shall be fastened to the ceiling with following specifications:

- The maximum axial load per bolt will not exceed 7210 N.
- The maximum Shear load per bolt will not exceed 957 N.
- The maximum pullout force shall be calculated in accordance with local building codes and it is part of structural analysis done by customer.

### 2.3.4.3.3 False ceiling specifications

The false ceiling should include an opening around the interface plate to allow service engineers to install and replace the suspension and the Large Display Monitor.

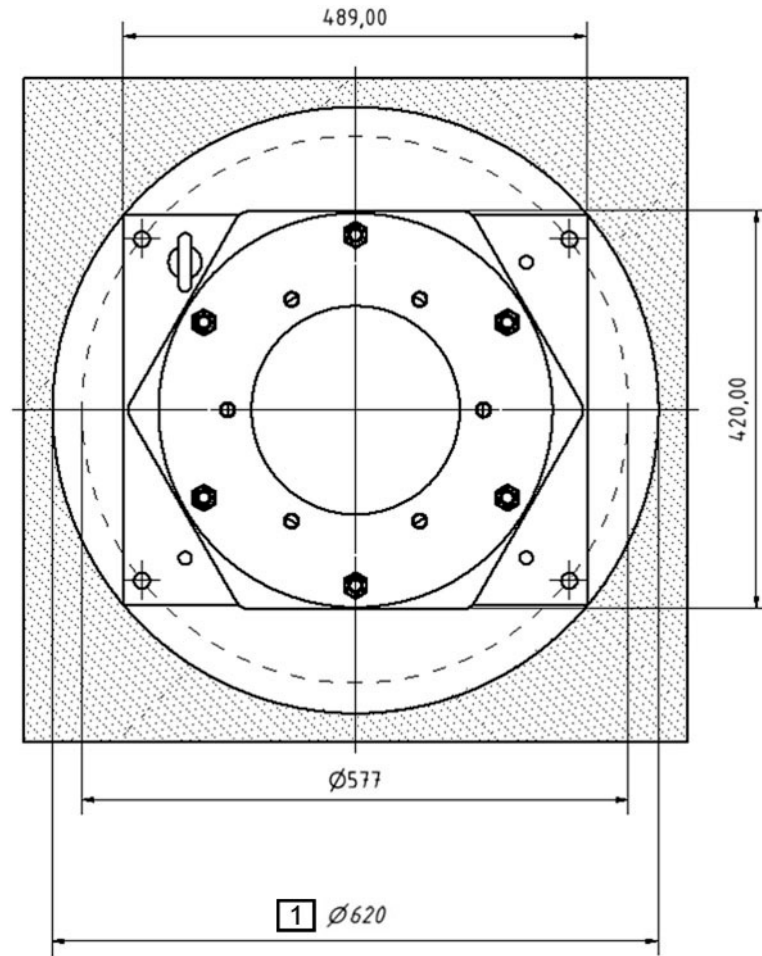
The diameter of the opening should be in the range of:

- 489-620 mm (Figure 2-96 on page 131) for a suspension for a Large Display Monitor.

A trapdoor in the false ceiling should be provided to allow service access for cables management after mechanical installation of the suspension.

The distance between the substructure and the trapdoor should be less than 50 cm.

**Figure 2-96**



[1]: Port diameter of the false ceiling: maximum is 620 mm.

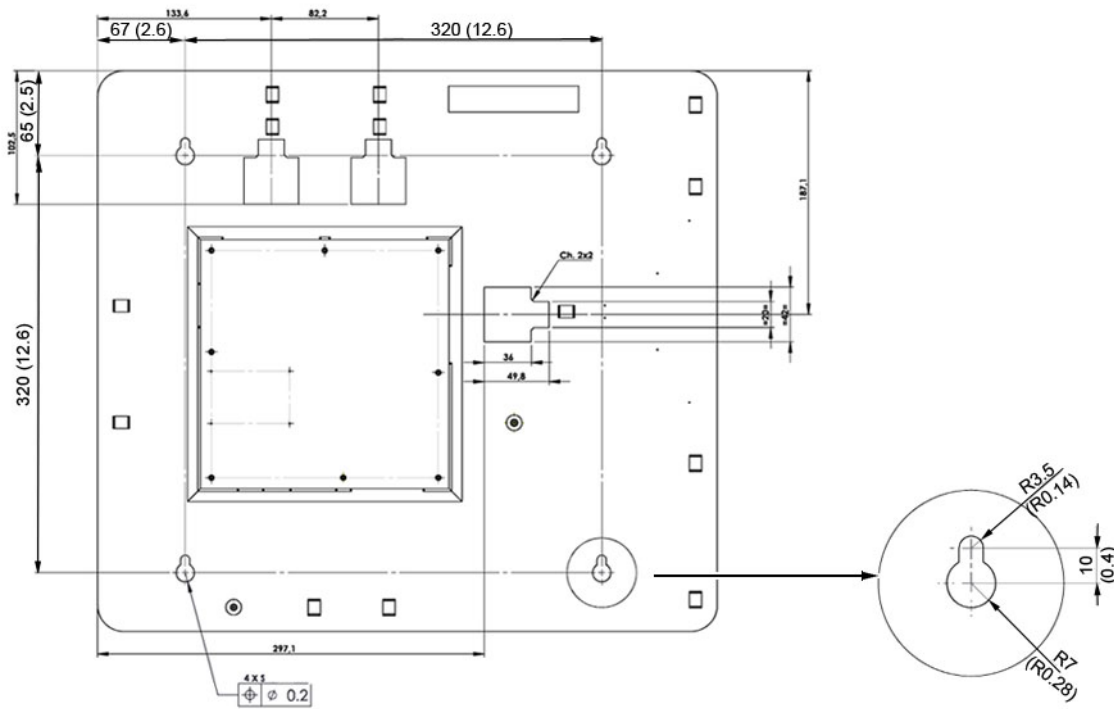
## 2.3.5 Wall Requirements

### 2.3.5.1 I-Box Installation

**(For Omega Table and for Innova IQ Table with IGS Control Center)** The I-Box is securely fastened to the Technical Room wall with four anchors and fixation screws.

The four anchors and fixation screws are not supplied with the I-Box. The fixations shall be sized to support a load of 15 kg (33 lb). Use anchors and screws recommended for the Technical Room wall material.

**Figure 2-97 I-Box fixation points**



Dimension in mm (in)

**2.3.5.2 (For IGS Control Center) I-Points**

The 2 I-Points are the connection points of the IGS Control Center. They shall be fixed to the wall of the Exam Room.

Their position is determined by the customer during the layout consideration.

It is recommended to install the I-Points between 800 mm and 1200 mm from finished floor.

The I-Points can be installed on plaster walls or structural walls.

For plaster walls, the minimum required inner distance between the structural wall and the plaster wall is 70 mm.

For structural walls, the I-Point shall be installed in an additional device (e.g. box) to allow its installation on the wall.

Conduits on the wall are also necessary to route the cables. These devices are not provided by GE and must be designed, calculated and supplied locally.

Means of fixation of the I-Points are not delivered with the system (to be provided by the hospital). I-Points must be securely fastened to the Exam Room walls.

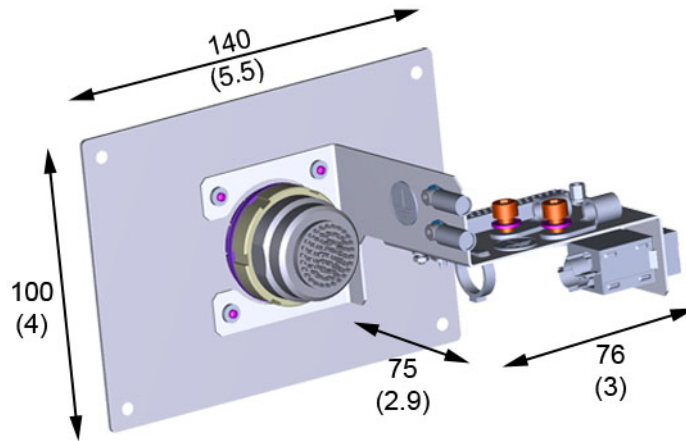
The recommended opening dimensions in the plaster wall or box are:

- Hole diameter 90 mm or hole 100 mm x 70 mm for the I-Points.

I-Point dimensions:

- Length: 140 mm
- Width: 100 mm
- Depth: 75 mm

Figure 2-98

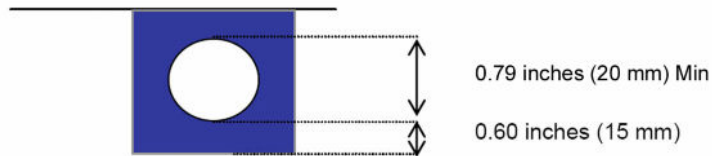


### 2.3.5.3 Optional Large Display secondary monitor

A hooking point shall be provided in order to lift the monitor on a third-party suspension during installation:

- Hooking point characteristic: It must withstand up to 440 lbs (200 kg).
- Recommended hooking point dimensions:

Figure 2-99 Hooking point dimensions



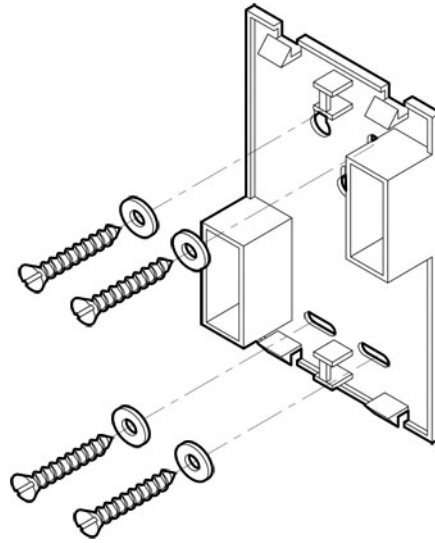
### 2.3.5.4 V-Point

The V-Point wall box is attached on the wall with four screws and four flat washers. The V-Point on a boom is attached with two screws.



**NOTE**

The V-Point screws and washers are not provided with the kit. They should be provided under customer responsibility.

**Figure 2-100 V-Point Box attached on the wall**

## 2.4 Seismic

### Seismic areas

Consider local seismic requirements when planning cabinet mounting.

Consult seismic expert to determine which mounting method is appropriate for the seismic region. Seismic requirements are determined and specified by the hospital/ Design Professional of record and may require approval by the specific state or country agency. Additional reinforcement in the walls may be required by specific seismic areas.

Contact your local GE Installation Program Manager to obtain the latest seismic calculations per the California Building Code (CBC) and the International Building Code (IBC).

The C-FRT Cabinet and the PDU V2 or X-PDU must be securely fastened to the wall and with their seismic kit to prevent them from tipping.

The C-FRT Cabinet, the Detector Conditioner, the Tube Cooling Unit and the 20 kVA Fluoro UPS are each provided with their own seismic kits, excluding the bolts, that shall be provided locally by the customer.

The following seismic kits can be ordered separately (on option):

- PDU V2 seismic kit: S18761PR
- X-PDU seismic kit: S18631SP
- Monitor Flat Panel seismic kit: 5561139
- VCIM seismic kit: 2365510
- 8 kVA UPS seismic kit: E4502YB.
- Fluoro UPS (11 kVA) seismic kit: E4502YB.

**(For LDM Suspension with fixed point Dual Arm) :**

**CAUTION**

The standard substructure (MAVIG GD60D022) should not be used with system in seismic zone.

Contact MAVIG or Local contractor to design and supply specific substructure including M12 threaded holes requirement (see below).

Four M12 threaded holes with hooking point are required for the installation of the dual arm suspension, the installation and replacement of the Large Display Monitor. The structural support plate ([Figure 2-55 MAVIG suspension with fixed point dual arm for Large Display Monitor - CoG on page 94](#)) should include these 4 x M12 threaded holes.

For the threaded holes positioning on the structural support plate refer to [Figure 2-51 Ceiling Plate of Substructure for Dual Arm suspension - Dimensions on page 90](#).

## Center of Gravity

Refer to [2.1.3 Dimension Drawings on page 55](#) for location of Center of Gravity (CoG) of the system components.

## 3 Special Construction Requirements

### 3.1 Radiation Protection

Because X-ray equipment produces radiation, special precautions may be needed or special site modifications may be required. GE HealthCare does not make recommendations regarding radiation protection. It is the customer's responsibility to consult a radiation physicist for advice on radiation protection in x-ray rooms.

The IGS system is equipped with the high-performance, highly reliable monopolar liquid metal bearing Performix™ Pulsar X-ray tube, with digital cathode, digitally controlled electric field to focus and shape the electron beam, that allows to control shape and size of the focal spot with the highest precision for high definition imaging, and to meet requirements for all vascular applications.

Anode diameter	160 mm brazed graphite
Anode rotation	9600 rpm / 160 Hz
Anode Target angle	11.25°
Anode heat storage capacity	12.3 MHUeff
Anode steady state heat dissipation	1100 KHU/min (13.5 kW)
Cathode	Tri-filament design
Coincident focal spot sizes	0.3, 0.5 and 0.8
Fluoroscopic power	<ul style="list-style-type: none"> <li>• 3200 W (continuous)</li> <li>• 4500 W (during 10 minutes)</li> </ul>
Maximum casing heat storage	5.8 MJ (7.8 MHU)
Continuous casing heat dissipation	3200 W
Maximum anode cooling rate	1100 KHU/min (13.5 kW)
Permanent filtration	1.2 mm Al / 75 IEC 60522-1-2020
Leakage radiation (IEC 60601-1-3)	< 50 mR/hr at 125 kV and 25.6 mA

### 3.2 Protection against electromagnetic interference hazards

Information below on IEC60601-1-2 and YY9706.102 Electromagnetic Standard Compliance & Documentation can also be found in the IGS System Operator Manual.

#### General Scope

This equipment complies with IEC60601-1-2 Edition 4.1 and YY9706.102 EMC standard for medical devices. It was also tested according to the recommendations of IEC TR 60601-4-2: Medical electrical equipment – Part 4-2: Guidance and interpretation – Electromagnetic immunity: performance of medical electrical equipment and medical electrical systems.

The IGS system is intended to be used:

- in a PROFESSIONAL HEALTHCARE facility environment,

- in a SPECIAL ENVIRONMENT for IGS systems in Surgical configuration (vicinity of active HF SURGICAL EQUIPMENT - refer to [Installations Requirements & Environment Control on page 143](#)).

The System is suitable to be used in the electromagnetic environment, as per the limits and recommendations described in the tables here after:

- Emission Compliance level and limits (see [Electromagnetic Emission on page 137](#)).
- Immunity Compliance level and recommendations to maintain equipment clinical utility (refer to [Table 3-2 on page 138](#), [Table 3-3 on page 139](#) and [Table 3-6 on page 143](#)).

## Immunity performance criteria list

Immunity performance criteria (IEC TR 60601-4-2)	What happens if the performance is lost due to electromagnetic disturbance*
Display of information	Information related to system status are not available/visible on DL console nor Touch Panel, End user could not use DL keypad nor Touch Panel.
Advanced processing availability	Dose map / StentViz / StentVesselViz / IRB features could not be activated by the user.
Automatic repositioning of table and gantry	Repositioning function is interrupted or not operational.
Patients database (exam mgt / browser)	Patient information (information, exams, sequences, and photos) are not accessible.
Acquisition settings	Inability to choose protocol / framerates / acquisition types Inability to lock/unlock X-rays Inability to modify injection parameters
Motion speed optimization	Motions speed is not reduced or stopped
System initialization at power ON	IGS system functions in exam mode are not available



**NOTE**

\* If any immunity performance criterion is degraded or lost due to transient electromagnetic disturbances, the IGS system has to be shut down and then powered-up. The performance criterion will be recovered and available after the shutdown / power-up sequence.

## Electromagnetic Emission

The IGS System is intended for use in the electromagnetic environment specified below.

The customer or the user of the IGS system should assure that it is used in such an environment.

**Table 3-1**

Emissions	Compliance	Electromagnetic Environment
Radio-Frequency Emissions CISPR 11 (GB 4824)	Group1 Class A Limits (see the Note below the table).	The IGS system uses Radio Frequency energy only for its internal function. Therefore, its Radio Frequency emissions are very low and are not likely to cause any interference in nearby electronic equipment.
		The IGS system is suitable for use in all establishments other than domestic and those directly connected to the public low-voltage power supply network that supplies buildings used for domestic purposes.

**Table 3-1** (Table continued)

Emissions	Compliance	Electromagnetic Environment
Harmonic emissions IEC61000-3-2 (GB 17625.1)	Not Applicable	The IGS system is suitable for use in all establishments other than domestic and those directly connected to the public low-voltage power supply network that supplies buildings used for domestic purposes.
Voltage fluctuations / flicker emissions IEC61000-3-3 (GB 17625.2)	Not Applicable	The IGS system is suitable for use in all establishments other than domestic and those directly connected to the public low-voltage power supply network that supplies buildings used for domestic purposes.



**NOTE**

The EMISSIONS characteristics of this equipment make it suitable for use in industrial areas and hospitals (CISPR 11 (GB 4824) class A). If it is used in a residential environment (for which CISPR 11 (GB 4824) class B is normally required), this equipment might not offer adequate protection to radio-frequency communication services. The user might need to take mitigation measures, such as relocating or re-orienting the equipment.

## Electromagnetic Immunity

### Electromagnetic Immunity IEC 60601-1-2 and YY9706.102

The IGS system is intended for use in the electromagnetic environment specified below.

The customer or the user of the IGS system should assure that it is used in such an environment.

**Table 3-2**

IMMUNITY Test	YY9706.102 Test Level	IEC TR 60601-4-2 Ed 1 Test Level (professional healthcare environment)	IEC60601-1-2 Ed 4.1 Test Level (professional healthcare environment)	Compliance Level	Electromagnetic Environment
Electrostatic discharge (ESD) IEC61000-4-2 (GB/T 17626.2)	+/- 6 kV contact +/- 8 kV air	+/- 4 kV contact +/- 8 kV air	+/- 8 kV contact +/- 15 kV air	+/- 8 kV contact +/- 15 kV air	Floors are wood, concrete or ceramic tile or floors are covered with synthetic material and the relative humidity is at least 20 %.
Electrical fast transient/burst IEC61000-4-4 (GB/T 17626.4)	+/- 2 kV for power supply lines +/- 1 kV for input/ output lines 5 kHz or 100 kHz burst repetition frequency	+/- 1 kV for power supply lines +/- 0.5 kV for input/ output lines 5kHz or 100 kHz burst repetition frequency	+/- 2 kV for power supply lines +/- 1 kV for input/ output lines 100 kHz burst repetition frequency	+/- 2 kV for power supply lines +/- 1 kV for input/ output lines 100 kHz burst repetition frequency	Mains power quality is that of a typical commercial or hospital environment.
Surge IEC61000-4-5 (GB/T 17626.5)	+/- 1 kV line(s) to line(s) +/- 2 kV line(s) to earth	+/- 1 kV line(s) to line(s) +/- 2 kV line(s) to earth	+/- 1 kV line(s) to line(s) +/- 2 kV line(s) to earth	+/- 1 kV line(s) to line(s) +/- 2 kV line(s) to earth	Mains power quality is that of a typical commercial or hospital environment.

**Table 3-2** (Table continued)

IMMUNITY Test	YY9706.102 Test Level	IEC TR 60601-4-2 Ed 1 Test Level (professional healthcare environment)	IEC60601-1-2 Ed 4.1 Test Level (professional healthcare environment)	Compliance Level	Electromagnetic Environment
Voltage dips, short interruptions and voltage variations on power supply input lines IEC61000-4-11 (GB/T 17626.11)	<5% U <sub>T</sub> (>95% dip in U <sub>T</sub> ) for 5 sec	0% U <sub>T</sub> ; 250/300 cycle	0% U <sub>T</sub> ; 250/300 cycle	<5% U <sub>T</sub> (>95% dip in U <sub>T</sub> ) for 5 sec 0% U <sub>T</sub> ; 250/300 cycle	Mains power quality is that of a typical commercial or hospital environment. If the user of the IGS system requires continued operation during power mains interruptions, it is recommended that the IGS system be powered from an uninterruptible power supply.
Power frequency (50/60 Hz) magnetic field IEC61000-4-8 (GB/T 17626.8)	3 A/m	3 A/m	30 A/m	30 A/m	Power frequency magnetic fields is at levels characteristic of a typical location in a typical commercial or hospital environment.
Proximity magnetic Fields IEC61000-4-39	-	-	65 A/m at 134,2 kHz 7,5 A/m at 13,56 MHz	65 A/m at 134,2 kHz 7,5 A/m at 13,56 MHz	It is recommended that magnetic field sources such as RFID readers shall be kept at least 0.15m from the IGS system.



**NOTE**

U<sub>T</sub> is the AC mains voltage prior to application of the test level. 250/300 cycle means 250 periods at 50Hz or 300 periods at 60Hz.


The IGS system is intended for use in the electromagnetic environment specified below.

The customer or the user of the IGS system should assure that it is used in such an environment.

**Table 3-3**

IMMUNITY Test	YY9706.102 Test Level	IEC TR 60601-4-2 Ed 1 Test Level (professional healthcare environment)	IEC60601-1-2 Ed 4.1 Test Level (professional healthcare environment)	Compliance Level	Electromagnetic Environment
Conducted Radio Frequency IEC61000-4-6 (GB/T 17626.6)	3 Vrms 150 kHz to 80 MHz	3 Vrms 150 kHz to 80 MHz	3 Vrms 150 kHz to 80 MHz 6 Vrms in ISM bands <sup>(1)</sup>	V1 = 3 Vrms 150 kHz to 80 MHz 6 Vrms in ISM bands <sup>(1)</sup>	Portable and mobile RF communications equipment is used no closer to any part of the IGS system, including cables, than the recommended separation distance calculated from the equation applicable to the frequency of the transmitter.  Recommended separation distance:

**Table 3-3** (Table continued)

IMMUNITY Test	YY9706.102 Test Level	IEC TR 60601-4-2 Ed 1 Test Level (professional healthcare environment)	IEC60601-1-2 Ed 4.1 Test Level (professional healthcare environment)	Compliance Level	Electromagnetic Environment
Radiated Radio Frequency IEC61000-4-3 (GB/T 17626.3)	3 V/m 80 MHz to 2.5 GHz	3 V/m 80 MHz to 2.7 GHz	3 V/m 80 MHz to 2.7 GHz	E1 = 3 V/m <sup>(4)</sup>	$d = \left[ \frac{3.5}{V_1} \right] \sqrt{P}$ $d = \left[ \frac{3.5}{E_1} \right] \sqrt{P} \quad 80 \text{ MHz to } 800 \text{ MHz}$ $d = \left[ \frac{7}{E_1} \right] \sqrt{P} \quad 800 \text{ MHz to } 2.5 \text{ GHz}$ <p>where P is the maximum output power rating of the transmitter in watts (W) according to the transmitter manufacturer and d is the recommended separation distance in metres (m).</p> <p>Field strengths from fixed RF transmitters, as determined by an electromagnetic site survey<sup>(2)</sup>, are less than the compliance level in each frequency range.<sup>(3)</sup></p> <p>Interference may occur in the vicinity of equipment marked with the following symbol:</p> 



**NOTE**

<sup>(1)</sup> The ISM (Industrial, Scientific and Medical) bands between 0.15 MHz and 80 MHz are 6.765 MHz to 6.795 MHz; 13.553 MHz to 13.567 MHz; 26.957 MHz; and 40.66 MHz to 40.70 MHz.



**NOTE**

<sup>(2)</sup> Field strengths from fixed transmitters, such as base stations for cellular telephones and land mobile radios, amateur radio, AM and FM radio broadcast and TV broadcast cannot be predicted theoretically with accuracy. To assess the electromagnetic environment due to fixed RF transmitters, an electromagnetic site survey should be performed. If the measured field strength exceeds the RF compliance level above, observe the IGS system to verify normal operation in each use location. If abnormal performance is observed, additional measures may be necessary, such as re-orienting or relocating the IGS system.



**NOTE**

<sup>(3)</sup> Over the frequency range 150 kHz to 80 MHz, field strengths are less than 3 V/m.



**NOTE**

<sup>(4)</sup> Refer to the table and warning below.

**NOTICE**

The IGS System is a Large, Permanently-Installed Medical Equipment for which the simulated operation in an anechoic chamber is not feasible and consequently is exempt from the testing requirement specified by IEC 61000-4-3 (GB/T 17626.3).

The IGS System has not been tested for radiated RF immunity over the entire frequency range 80 MHz to 6 GHz.

The IGS System has been tested for radiated RF immunity only at selected frequencies. Use nearby of emitters at other frequencies could result in improper operation.

**Table 3-4 YY9706.102, IEC TR 60601-4-2 and IEC 60601-1-2 field level and frequencies**

Tested frequencies (MHz)	Field level (V/m)	Modulation
433.92 (ISM) <sup>(5)</sup>	3	80 % AM at 1 kHz rate
915 (ISM) <sup>(5)</sup>		
1440		
1750		
1920		
2450 (ISM) <sup>(5)</sup>		



**NOTE**

<sup>(5)</sup> Industrial, Scientific and Medical (ISM) radio bands.



**NOTE**

These are guidelines. Actual conditions may vary.

The associated recommended separation distances as per YY9706.102-2012 are listed in section [Recommended Separation Distances for Portable and Mobile RF Communications Equipment YY9706.102 on page 143](#).

Additional IEC TR 60601-4-2 Ed 1.0 and IEC60601-1-2 Ed 4.1 field level & frequencies - immunity to proximity fields from RF wireless equipment:

**Table 3-5 IEC TR 60601-4-2 Ed 1.0 and IEC60601-1-2 Ed 4.1 field level & frequencies**

Tested frequencies (MHz)	IEC TR 60601-4-2 Ed 1 Field level (V/m)	IEC 60601-1-2 Ed 4.1 Field level (V/m)	Compliance Level (V/m)	Modulation
385	6	27	27	Pulse modulation (50% duty cycle) – 18 Hz
450	9	28	28	Pulse modulation (50% duty cycle) – 18 Hz
710	3	9	9	Pulse modulation (50% duty cycle) – 217 Hz
745	3	9	9	Pulse modulation (50% duty cycle) – 217 Hz
780	3	9	9	Pulse modulation (50% duty cycle) – 217 Hz
810	9	28	28	Pulse modulation (50% duty cycle) – 18 Hz

**Table 3-5 IEC TR 60601-4-2 Ed 1.0 and IEC60601-1-2 Ed 4.1 field level & frequencies (Table continued)**

Tested frequencies (MHz)	IEC TR 60601-4-2 Ed 1 Field level (V/m)	IEC 60601-1-2 Ed 4.1 Field level (V/m)	Compliance Level (V/m)	Modulation
870	9	28	28	Pulse modulation (50% duty cycle) – 18 Hz
930	9	28	28	Pulse modulation (50% duty cycle) – 18 Hz
1720	9	28	28	Pulse modulation (50% duty cycle) – 217 Hz
1845	9	28	28	Pulse modulation (50% duty cycle) – 217 Hz
1970	9	28	28	Pulse modulation (50% duty cycle) – 217 Hz
2450 (ISM) <sup>(6)</sup>	9	28	28	Pulse modulation (50% duty cycle) – 217 Hz
5240	6	9	9	Pulse modulation (50% duty cycle) – 217 Hz
5500	6	9	9	Pulse modulation (50% duty cycle) – 217 Hz
5785	6	9	9	Pulse modulation (50% duty cycle) – 217 Hz
5800 (ISM) <sup>(6)</sup>	6	9	9	Pulse modulation (50% duty cycle) – 217 Hz



**NOTE**

<sup>(6)</sup> Industrial, Scientific and Medical (ISM) radio bands.



**NOTE**

These are guidelines. Actual conditions may vary.

Equipment used for tests:

- RF signal generator.
- RF power amplifier.
- Transmitting antenna.
- Field sensor.
- Field meter.

**WARNING**



PORTABLE RF COMMUNICATIONS EQUIPMENT INCLUDING PERIPHERALS (SUCH AS ANTENNA CABLES AND EXTERNAL ANTENNAS) SHOULD BE USED NO CLOSER THAN 30 CM (12 INCHES) TO ANY PART OF THE IGS SYSTEM INCLUDING CABLES SPECIFIED BY THE MANUFACTURER. OTHERWISE, DEGRADATION OF THE PERFORMANCE OF THIS EQUIPMENT COULD RESULT.

## Recommended Separation Distances for Portable and Mobile RF Communications Equipment YY9706.102

Table 3-6

Frequency of Transmitter	150 KHz to 80 MHz	80 MHz to 800 MHz	800 MHz to 2.5 GHz
Equation	$d=[3.5 / V1].\sqrt{P}$	$d=[3.5 / E1].\sqrt{P}$	$d=[7 / E1].\sqrt{P}$
Rated Power of Transmitter (watts)	Distance (meters)	Distance (meters)	Distance (meters)
10 mW	0.11	0.11	0.22
100 mW	0.37	0.37	0.74
1	1.1	1.1	2.3
10	3.7	3.7	7.4
100	12	12	23

For transmitters rated at a power not listed above, the DISTANCE can be estimated using the equation in the corresponding column, where P is the power rating of the transmitter in watts (W) according to the transmitter manufacturer.



**NOTE**

E1 and V1 values are defined in [Electromagnetic Immunity on page 138](#). These are guidelines. Actual conditions may vary.

### Limitations Management

Adhering to the distance separation recommended in section [Recommended Separation Distances for Portable and Mobile RF Communications Equipment YY9706.102 on page 143](#), between 150 kHz and 2.5 GHz, will reduce disturbances recorded at the image level, but may not eliminate all disturbances. However, when installed and operated as specified herein, the system will maintain its essential performance by continuing to acquire, display, and store diagnostic quality images safely.

For example, a 1 W mobile phone (800 MHz to 2.5 GHz carrier frequency) shall be put 2.3 meters (refer to [Table 3-6 on page 143](#) in section [Recommended Separation Distances for Portable and Mobile RF Communications Equipment YY9706.102 on page 143](#), apart from the IGS system (in order to avoid images interferences risks).

### Installations Requirements & Environment Control

**WARNING**



USE OF ACCESSORIES, TRANSDUCERS AND CABLES OTHER THAN THOSE SPECIFIED OR PROVIDED BY THE MANUFACTURER OF THIS EQUIPMENT COULD RESULT IN INCREASED ELECTROMAGNETIC EMISSIONS OR DECREASED ELECTROMAGNETIC IMMUNITY OF THIS EQUIPMENT AND RESULT IN IMPROPER OPERATION.

In order to minimize interference risks, the following requirements shall apply:

- Separated Power supply distribution panel & separated power line.
- Stacked components and equipment:  
The IGS system should not be used adjacent to or stacked with other equipment.
- Low frequency magnetic field: other electrical equipment may disturb and interfere with these IGS components. The control of the clearing distances from the noise sources is recommended

from the HF electrosurgery generator, power supplies converters from nearby monitors or from other close electrical equipment). Refer to respective device manufacturers instructions and recommendations in such cases.

- In order to minimize the risk of interference from a nearby MRI device, the recommended maximum static magnetic field amplitudes are specified below:
  - Static field is specified less than <1 Gauss in Exam room, and in the Control Room.
  - Static field is specified less than <3 Gauss in the Technical Room.
- Electrostatic discharges environment and recommendations:
  - In order to reduce electrostatic discharge interference, install a charge dissipative floor material to avoid electrostatic charge buildup.
  - The relative humidity shall be at least 20 percent as defined in [4.1.1 Humidity on page 145](#).
  - The dissipative material shall be connected to the system ground reference, if applicable.

## 4 Environmental Requirements

### 4.1 Humidity, Temperature and Altitude

#### 4.1.1 Humidity

**Table 4-1 Relative Humidity (non- condensing)**

	MIN	MAX
Exam Room	20%	70%
Control Room	20%	75%
Technical Room	20%	75%

#### 4.1.2 Temperature and Altitude

The system is certified for use up to 3000 m. The permissible atmospheric pressure conditions of use are between 700 hPa and 1060 hPa.

Above 2000 m, the thermal dissipation is reduced because the air pressure is lower. Therefore, a temperature derating shall be applied for the Technical Room as defined in the table below.

The 20 kVA Fluoro UPS CE can be used only below 2000 m.

**Table 4-2 Exam Room and Control Room - Temperature**

	MIN	MAX	RECOMMENDED
Exam Room	+15°C (+59°F)	+32°C (+90°F)	+20°C (+68°F)
Control Room	+15°C (+59°F)	+35°C (+95°F)	+20°C (+68°F)

**Table 4-3 Technical Room - Temperature**

	Temperature up to 2000 m			Temperature above 2000 m		
	MIN	MAX	RECOMMENDED	MIN	MAX	RECOMMENDED
Technical Room	+15°C (+59°F)	+25°C (+77°F)	+20°C (+68°F)	+15°C (+59°F)	+20°C (+68°F)	+20°C (+68°F)



#### NOTE

For the systems that are planned to be installed at the second floor or above, the temperature and humidity of the rooms that are directly below the gantry room should be the same as the Exam Room requirement.

Differences in temperature or humidity between the Exam room and the room located below will cause condensation within the gantry or patient table, resulting in part failure or rust. Failure to do so will void the equipment warranty. Avoid above grade installations if the temperature is high in the area below the cables entrance of the gantry or table.

## 4.2 Heat Output

In the table:

- Moderate Use corresponds to 8 cases per a 10 hours day,
- Typical Use corresponds to 11 cases per a 10 hours day,
- Maximum Use is maximum peak power during exam.

**Table 4-4**

		HEAT OUTPUT							
		Stand by		Moderate Use		Typical Use		Maximum Use	
Room	Core System	kW	BTU/hr	kW	BTU/hr	kW	BTU/hr	kW	BTU/hr
Exam Room	Gantry and Table	0.41	1,399	0.55	1,877	0.89	3,037	1.62	5,528
	LDM suspension with 2 backups	0.10	341	0.10	341	0.10	341	0.10	341
	Typical Injector	0.09	307	0.09	307	0.09	307	0.09	307
Control Room	DL console and Live monitor	0.10	341	0.10	341	0.10	341	0.10	341
Technical Room	C-FRT Cabinet	0.70	2,388	1.02	3,480	1.53	5,221	2.16	7,370
	PDU or X-PDU	0.50	1,706	0.50	1,706	0.50	1,706	0.50	1,706
	Tube Cooling Unit	0.56	1,927	2.57	8,769	2.77	9,482	3.47	11,857
	Detector Conditioner	0.21	717	0.21	717	0.21	717	0.21	717
	UPS 8 kVA	0.52	1,774	0.52	1,774	0.52	1,774	0.52	1,774
	Fluoro UPS (11 kVA)	0.52	1,774	0.52	1,774	0.52	1,774	0.52	1,774
	20 kVA Fluoro UPS UL	2.14	7,302	2.14	7,302	2.14	7,302	2.14	7,302
	20 kVA Fluoro UPS CE	0.585	2,000	0.585	2,000	0.585	2,000	0.585	2,000
Total for Core System with the 8 kVA UPS		3.19	10,900	5.66	19,312	6.71	22,926	8.77	29,941
Total for Core System with the Fluoro UPS (11 kVA)		3.19	10,900	5.66	19,312	6.71	22,926	8.77	29,941
Total for Core System with the 20 kVA Fluoro UPS UL		4.81	16,428	7.28	24,840	8.33	28,454	10.39	33,469
Total for Core System with the 20 kVA Fluoro UPS CE		3.255	11,126	5.725	19,538	6.775	23,152	8.835	30,167

## 4.3 Acoustic Specifications

- Less than 50 dB (A) at 1 meter for Gantry.
- Limited to 50 dB (A) at 1 meter for Omega IV Table and Omega V Table.
- Limited to 58 dB (A) at 1 meter for Innova<sup>IQ</sup> Table.
- Limited to 75 dB (A) at 1 meter for C-FRT Cabinet and PDU V2 or X-PDU.
- Limited to 70 dB (A) at 1 meter for Tube Cooling Unit.
- Limited to 52 dB (A) (background of 35 dB (A)) at 1 meter for Detector Conditioner.
- Limited to 39 dB (A) at 1 meter for UPS 8 kVA Gen1.

- Less than 37 dB (A) at 1 meter for UPS 8 kVA Gen2.
- Less than 50 dB (A) at 1 meter for Fluoro UPS (11 kVA).
- Less than 60 dB (A) at 1 meter for the 20 kVA Fluoro UPS.
- less than 55 dB (A) at 20 degrees Celsius, measured in the operators head position, 20 cm in front of the keyboard's right corner, at 1.30 m above the floor, and in a distance of 1 meter at all four sides.

## 4.4 Room Light

### 4.4.1 Requirements for Lighting

Requirement for lighting concern the following, general, light-technique characteristics:

- Illuminator level.
- Lighting distribution.
- Preventing the operator from being dazzled by the light (by direct light sources or by reflection on bright objects).

The Illumination level must be compliant with established lighting technical rules and be as constant as possible.

Technical Room, Exam Room and Control Room shall be provided with appropriate lighting in the maintenance area (maintenance area to be considered are service workplaces). It corresponds to service areas as defined for any of the product components.

The minimum required average luminance  $E_m$  shall be of 500 lux and minimum color rendering factor  $R_a$  of 80 as per IEC/EN 12464-1 (Light and lighting. Lighting of work places. Indoor work places: Illumination requirements for indoor workplaces corresponding to assembly of medium size electrical components, e.g. control panel) for the electrical industry).

### 4.4.2 Windows and Curtains

When the Exam Room has a window with an aperture outside of the controlled light area (day light, other...) a curtain has to maintain the light intensity under a limit fixed to 150 lux.



#### NOTE

In Germany: Ambient luminance of 100 lux maximum is required to maintain Exam Room class 2 according to DIN 6868-157.

### 4.4.3 Surgical Lights

#### WARNING



If a surgical light is installed by the customer, it has to be powered from an independent power supply (provided by the hospital not by the System).

## 5 Electrical Requirements

### 5.1 System Electrical Ratings

Table 5-1

Nominal voltage	Frequency	Type of power input		Power consumption				
		With 8 kVA UPS or Fluoro UPS (11 kVA)	With 20 kVA UPS	System Off	Standby	Long time	Momentary	Peak
380 V	50 Hz or 60 Hz	3~	3N~	0.4 kVA	3.1 kVA	15 kVA	100 kVA	150 kVA
400 V								
415 V								
440 V	60 Hz	3~	Not compatible	0.4 kVA	3.1 kVA	15 kVA	100 kVA	150 kVA
480V			3N~					

Long time rating is measured in fluoroscopy mode at 30 fps, 120 kV, 89 mA, 10 ms.

Momentary rating is measured in record DSA mode at 7.5 fps, 125 kV, 640 mA, 50 ms.

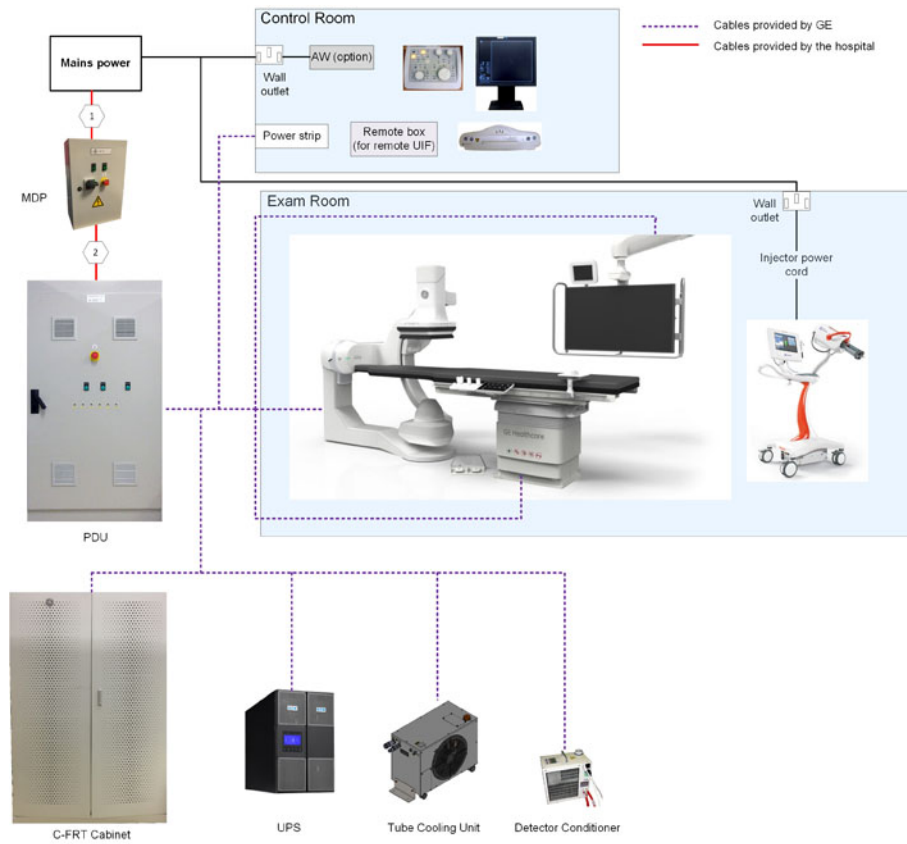
For the rating of the external devices not powered by the system (AW, injector, and so on), refer to the OEM documentation.

### 5.2 Power Distribution Schematics

Information below specifies the cables provided by GE and the cables provided by the Hospital. Refer to MDP [5.3 Cabling Requirements on page 152](#).

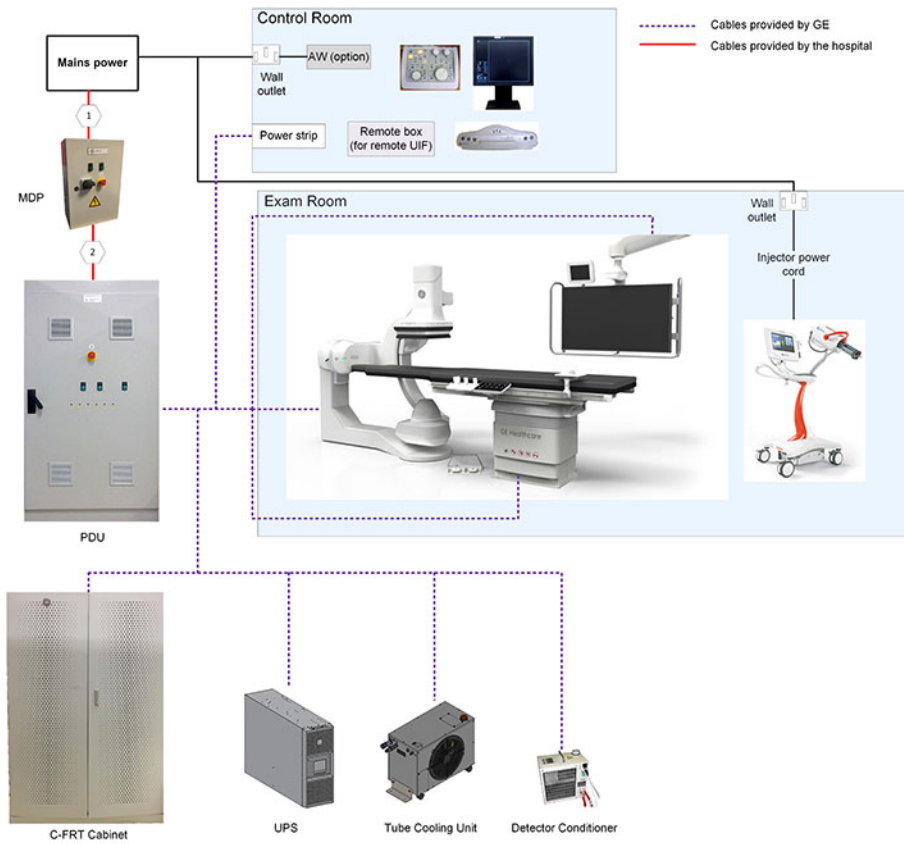
## 5.2.1 System with 8 kVA UPS

Figure 5-1 Power Distribution with 8 kVA UPS



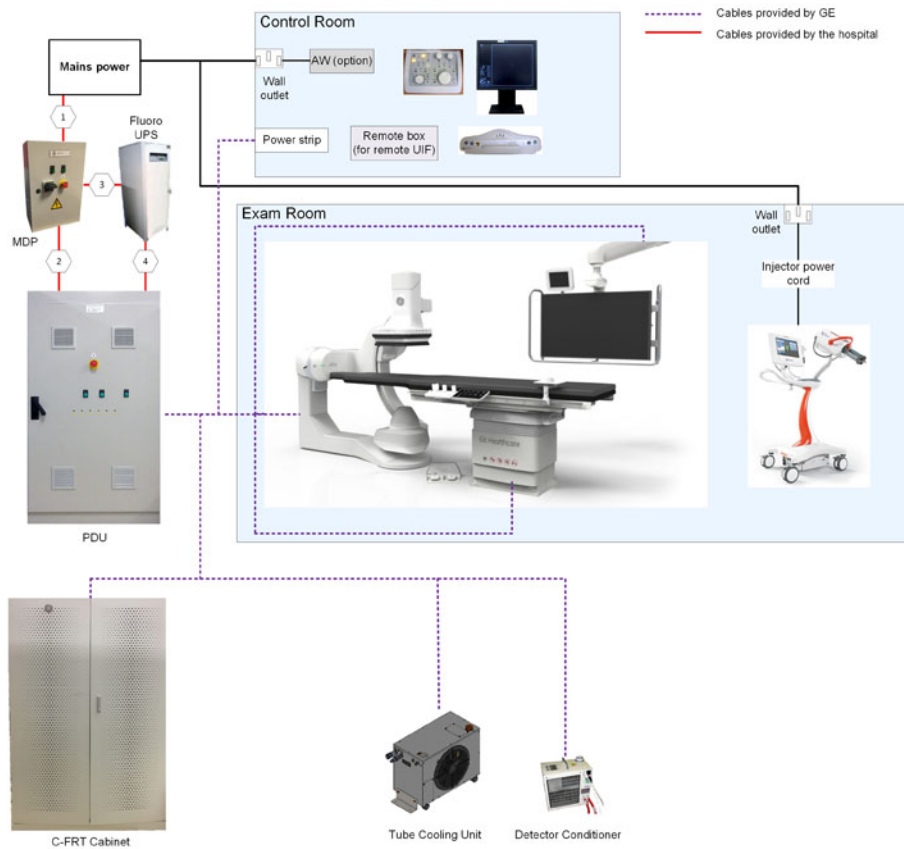
## 5.2.2 System with Fluoro UPS 11 kVA

Figure 5-2 Power Distribution with Fluoro UPS 11 kVA



### 5.2.3 System with 20 kVA Fluoro UPS

Figure 5-3 Power Distribution with 20 kVA Fluoro UPS



### 5.2.4 System with 20 kVA Fluoro UPS and IT Electrical Network

The 20 kVA Fluoro UPS requires a Neutral line connected to the Protective Earth. For hospitals with an IT Electrical Network, a transformer is required with Delta-Wye or Delta-Star connection.

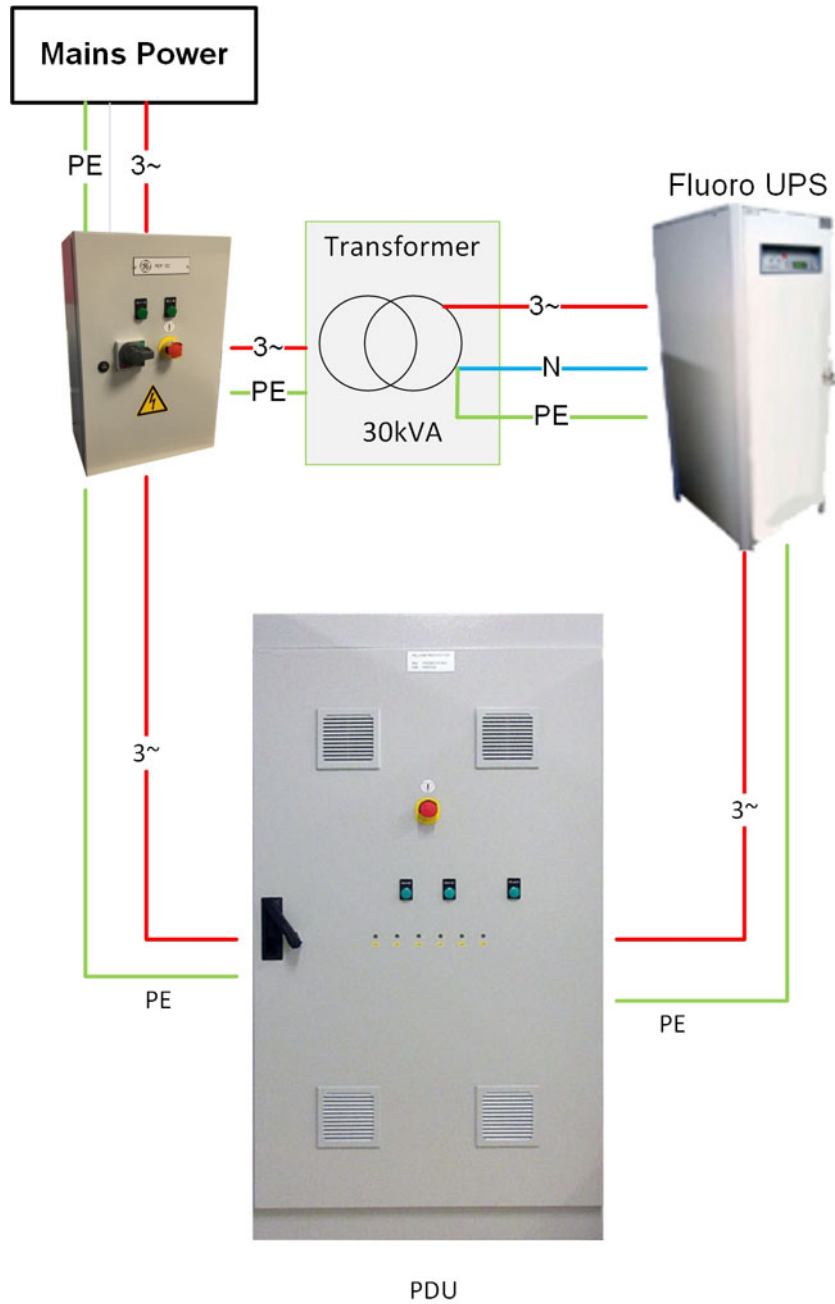
This transformer shall be provided by the customer; its characteristics shall be:

- 30 kVA minimum.
- Secondary star 3 Ph+N.
- The power distribution shall be of TNS type with the Neutral grounded.
- The transformer impedance shall be 4.5% or less (this parameter is also called %Z or short circuit voltage).

It is also the responsibility of the customer to provide:

- The box of the transformer to avoid access to live parts according to local regulations.
- The current protections at the output of the transformer, fuses or breaker, as per local regulations. The suggested rating is 50A.

Figure 5-4 Power Distribution with 20 kVA Fluoro UPS and IT Electrical Network



## 5.3 Cabling Requirements

It is the customer's responsibility to ensure that the electrical installation is compliant with local regulations, such as NFPA99 (Health Care Facilities Code) or 60364-7-710 (Requirements for special installations or locations - Medical locations).

To avoid risk of electric shock, this equipment must only be connected to a mains power supply with Protective Earth.

The power supply and ground cables shall be dedicated to the system. They must not be used to supply other systems. Power supply and ground cables shall be kept separated from other room System cables and must be connected to the same distribution panel. They must run near one to the other.

The power cables, ground cables and EPO cables provided by the customer shall be compliant with local regulations (e.g. UL, NFPA 70, CSA, IEC, CCC).

### 5.3.1 Power Source Characteristics

#### 5.3.1.1 Transformer

The transformer powering the system shall meet the following requirements:

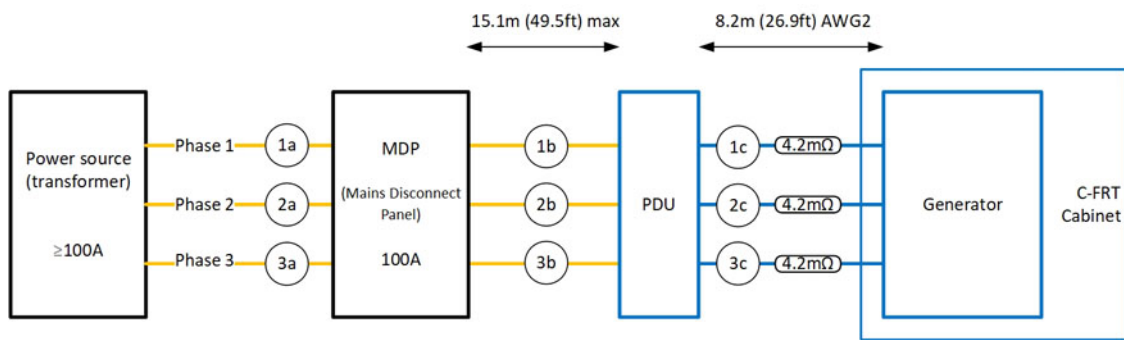
- 150 kVA minimum for input voltage of 380 V and 400 V.
- 100 kVA minimum for input voltage of 415 V, 440 V and 480 V.
- The transformer impedance shall be 4.5 % or less (this parameter is also called %Z or short circuit voltage).

The protection of the output of the transformer shall be sized 100A minimum

It shall provide a neutral for the systems with the 20kVA UPS (else refer to [5.2.4 System with 20 kVA Fluoro UPS and IT Electrical Network on page 151](#)).

#### 5.3.1.2 Power Cables (Feeders)

Figure 5-5



The power cables shall meet all the requirements below, whichever is the most stringent:

- 2 AWG / 35mm<sup>2</sup> minimum.
- The size of the power cables shall be adapted to the protection of the transformer, this means that the ampacity of the cables shall be greater or equal to the rating of the protection.
- The DC resistance of the power cables shall be less than the values defined in the [Table 5-2 on page 153](#). This means that the DC resistance of the cable 1a + cable 1b + cable 1c, cable 2a + cable 2b + cable 2c and cable 3a + cable 3b + cable 3c in [Figure 5-5 on page 153](#) shall all be less than the “Per phase” value.

The protective Earth cables shall not be smaller than the power cables (cables #1 & #2). The Protective Earth cable between the MDP and the PDU (cable #2) shall be separated from the power cable.

Max Line Impedance at the entry of the X-rays Generator in C-FRT Cabinet:

Table 5-2

Mains Voltage (V)	380	400	415	440	480
Max Line Impedance Phase to phase (Ω)	0.170	0.170	0.180	0.200	0.240

**Table 5-2** (Table continued)

Mains Voltage (V)	380	400	415	440	480
Max Line Impedance Per phase (Ω)	0.085	0.085	0.090	0.100	0.120

The maximum cable length between the MDP and the PDU shall be 20m (65.6ft). This cable shall be a copper cable and the cable insulation temperature shall be 90°C. Use cable Type S for North America



**NOTE**

The cables 1c, 2c and 3c are provided with the system, and are AWG2, 8.2m long. The DC resistance of each cable is 0.0042 Ohms.

The [Table 5-3 on page 154](#) is provided for information for the calculation of the DC resistance of copper cables, the calculation shall be done using the actual values in the datasheet of the cables that will be used.

**Table 5-3**

Resistivity of copper wires (for information)		
AWG	Diameter (mm <sup>2</sup> )	Resistivity (Ω/km)
0000 (4/0)	107	0.1608
000 (3/0)	85	0.2028
00 (2/0)	67	0.2557
0 (1/0)	53	0.3224
1	42	0.4066
2	35	0.5127

## 5.3.2 20 kVA Fluoro UPS Cables

### 5.3.2.1 20 kVA Fluoro UPS UL Power Cables

The minimum gauge of the power and Protective Earth from the MDP to the Fluoro UPS and from the Fluoro UPS to the PDU shall be 10 mm<sup>2</sup> / 6 AWG (cables # 3 and # 4 on [Figure 5-3 Power Distribution with 20 kVA Fluoro UPS on page 151](#)).

The Protective Earth cables shall not be smaller than the power cables.

### 5.3.2.2 20 kVA Fluoro UPS CE Power Cables

The gauge of the power and Protective Earth from the MDP to the Fluoro UPS shall be 10 – 16 mm<sup>2</sup> / 7 AWG - 5 AWG (cables # 3 on [Figure 5-3 Power Distribution with 20 kVA Fluoro UPS on page 151](#)).

The gauge of the power and Protective Earth from the Fluoro UPS to the PDU shall be 10 mm<sup>2</sup> / 7 AWG. (cable # 4 on [Figure 5-3 Power Distribution with 20 kVA Fluoro UPS on page 151](#)).

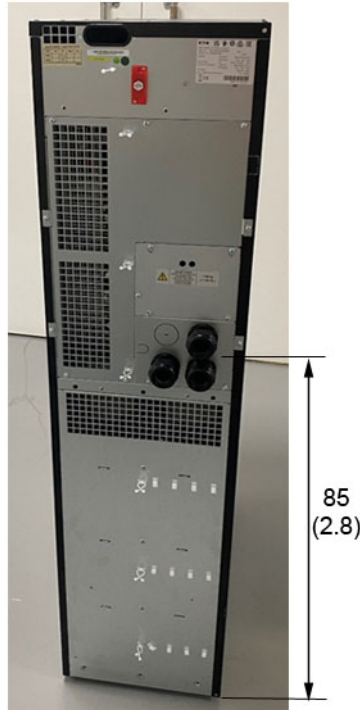
The Protective Earth cables shall not be smaller than the power cables.



**NOTE**

The entry point of the power cables at the back of the UPS is located 85 cm (2.8 feet) from the floor.

Figure 5-6



Dimension in cm (feet)

### 5.3.2.3 20 kVA Fluoro UPS Ethernet Cable

A 6 m Ethernet cable between the C-FRT Cabinet and the 20 kVA Fluoro UPS is provided with the system. If a longer cable is needed, it shall be provided by the hospital; it shall be Cat5 minimum.

## 5.3.3 EPO Cables and additional buttons

### 5.3.3.1 EPO Cable between the MDP and the PDU

The hospital shall provide an EPO cable between the MDP and the PDU; its minimum gauge shall be 1 mm<sup>2</sup> / 16 AWG and shall be in accordance with the rating of the fuse F2 of the MDP.

In case of 20 kVA Fluoro UPS, a 12 m EPO cable between the PDU V2 and the 20 kVA Fluoro UPS is provided with the system. If a longer cable is needed, it shall be provided by the hospital, its minimum gauge shall be 1 mm<sup>2</sup> / 16 AWG.

### 5.3.3.2 Additional EPO buttons

The PDU is provided with an EPO button on its front panel and provides the connection for additional EPO buttons (in Exam Room or Control Room).

The customer is responsible for the procurement, delivery and installation of the cables and EPO buttons. It is recommended not to locate the EPO in a high traffic area, or an area where someone could accidentally bump it, press it, and mistake it for a different button.

The EPO buttons shall provide 2 Normally Closed contacts, compatible with 24 V AC and in accordance with the MDP transformer rating. The maximum length of the cables shall be 24 m, the recommended diameter is 1 mm<sup>2</sup> / 16 AWG.

Once activated, the EPO button shall require a user action to deactivate it (for instance "Push to activate - Push to release" or lever type).

**WARNING**



ACCIDENTAL ACTIVATION OF AN EPO BUTTON CAN LEAD TO UNINTENDED INTERRUPTION OF A PATIENT PROCEDURE COUPLED WITH A DELAY WHEN RESETTING THE EPO, THEN REPOWERING AND REBOOTING THE SYSTEM.

THE POSITION OF THE ADDITIONAL EPO BUTTONS IN THE EXAM ROOM AND CONTROL ROOM SHALL ALLOW TO MINIMIZE ACCIDENTAL ACTIVATION BY A USER, SHOCK WITH A GURNEY...

PENDING HOSPITAL POLICIES AND LOCAL REGULATIONS, IT IS RECOMMENDED THAT THE EPO BUTTON BE PROTECTED AGAINST ACCIDENTAL ACTIVATION (FOR INSTANCE: RECESSING THE EPO INTO A WALL OR PUTTING IT INTO A BOX/FRAME (FIG BELOW) AND LABELED TO DISTINGUISH IT FROM OTHER BUTTONS, FOR INSTANCE: ROOM LIGHT BUTTON, CODE BLUE BUTTON, etc.) WITHIN THE ROOM.



Legend of Figure 5-7 EPO Schematic with 8 kVA UPS on page 157, Figure 5-8 EPO Schematic with Fluoro UPS (11 kVA) on page 157 and Figure 5-9 EPO Schematic with Fluoro UPS 20 kVA on page 158:

Item	Description
	Black line: Internal wiring and GE responsibility wiring
	Red line: External wiring (Customer responsibility)
[1]	Remote EPOs
[2]	UPS EPO
[3]	PDU Power Strip
[4]	PDU EPO
[5]	PDU Transformer temperature sensor
[6]	MDP

Item	Description
[7]	MDP EPO
[8]	MDP EPO internal circuit

Figure 5-7 EPO Schematic with 8 kVA UPS

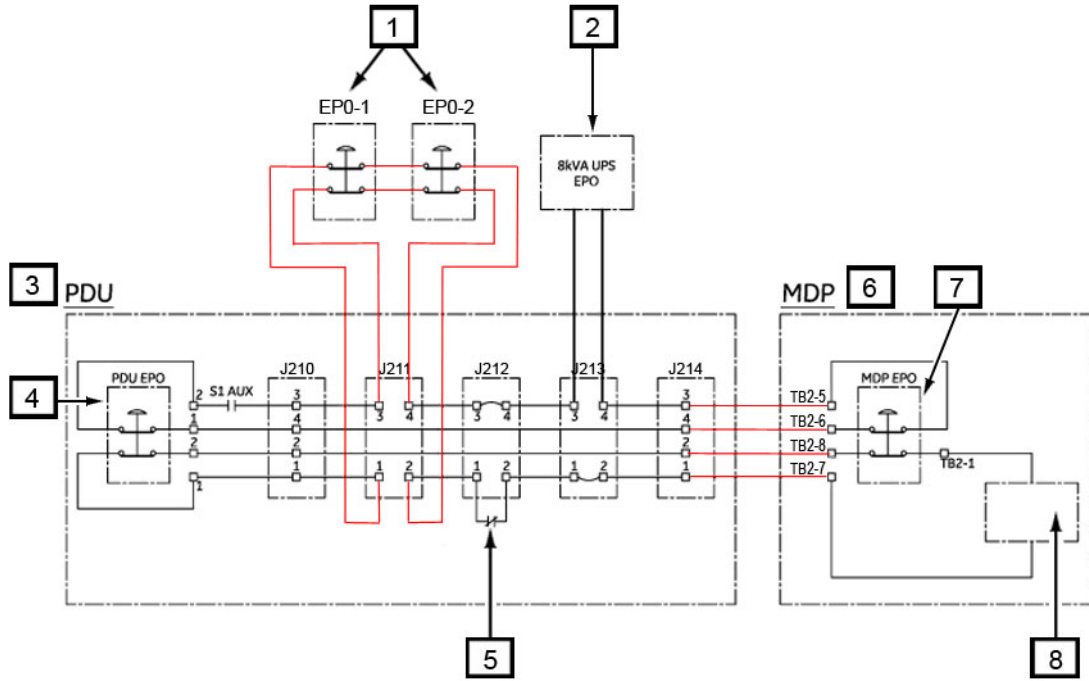


Figure 5-8 EPO Schematic with Fluoro UPS (11 kVA)

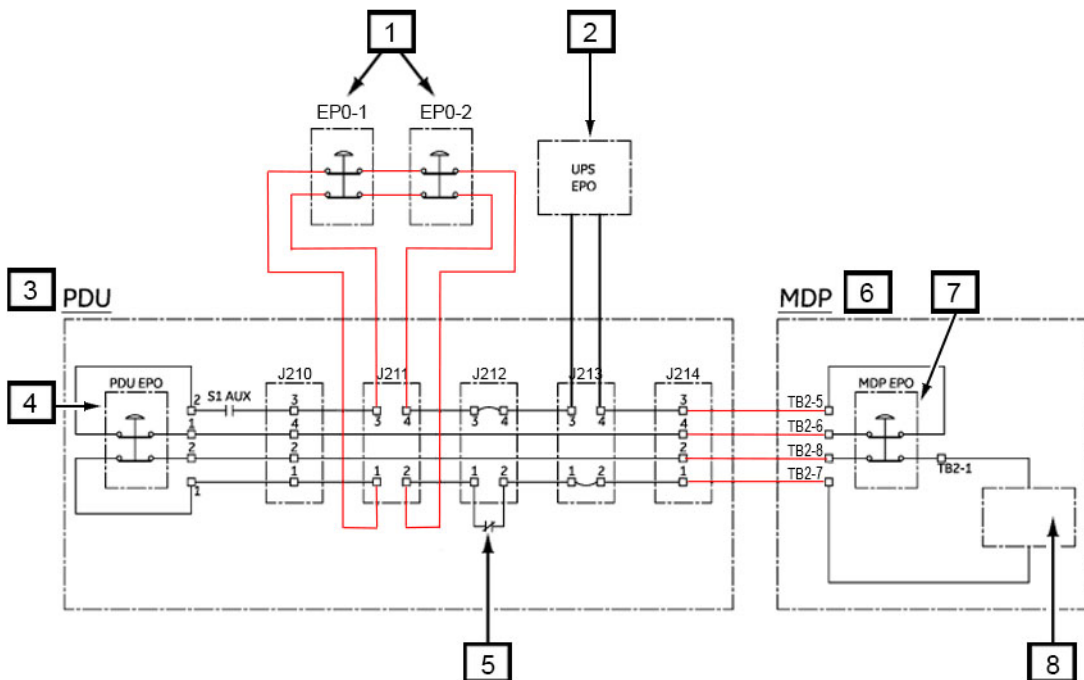
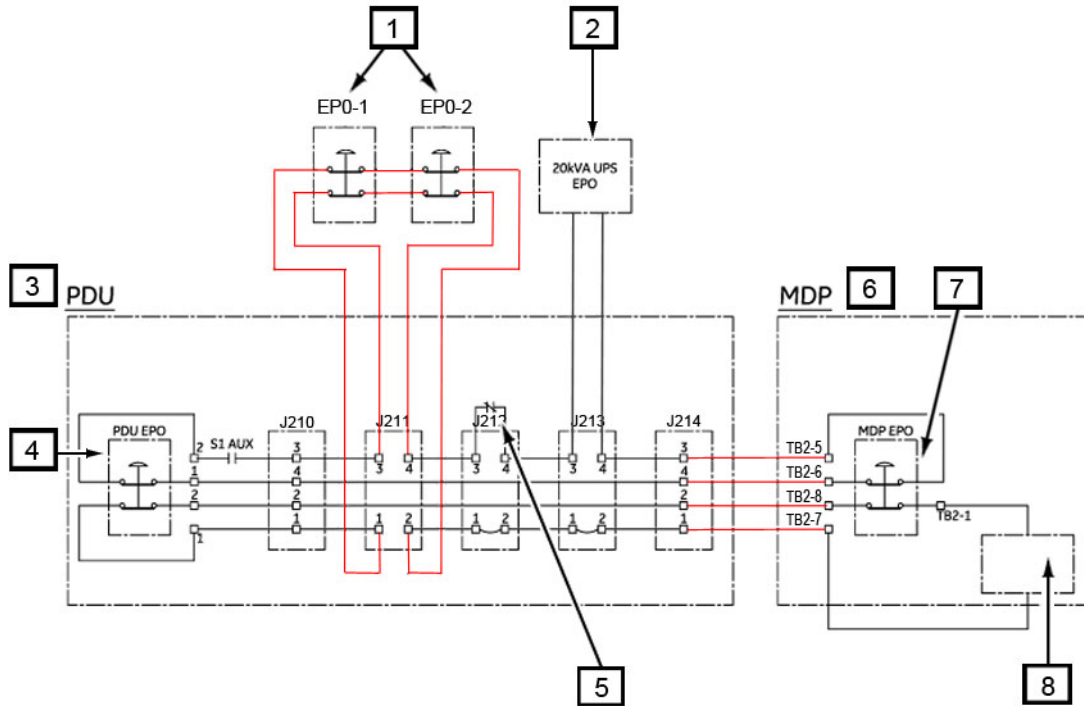


Figure 5-9 EPO Schematic with Fluoro UPS 20 kVA



**NOTE**

J212 connection:

- UPS 8 kVA: pair 1, 2 connected to Transformer EPO output, pair 3, 4 is shorted.
- Fluoro UPS (11 kVA): pair 1, 2 connected to Transformer EPO output, pair 3, 4 is shorted.
- UPS 20 kVA (Fluoro UPS): pair 3, 4 connected to Transformer EPO output, pair 1, 2 is shorted.

## 5.4 Mains Disconnect Panel

### 5.4.1 General Information

#### 5.4.1.1 Introduction

The Mains Disconnect Panel (MDP) is the electric panel which is the interface between the Hospital mains and the System. It allows the power connections from the hospital power to the input of the PDU or X-PDU of the system and to the 20 kVA Fluoro UPS if present. It provides the LOTO (lock out – tag out) functions that allows safe service operation, and is part of the EPO (Emergency Power Off) function.

As the requirements applicable to electric panels vary from a country to another, information below lists the GE mandatory requirements to provide safe system operation and the installation precautions, in addition to the local regulatory requirements.

Information given shall allow the Customer to build the MDP in compliance with GE's rules. In addition, the following MDP can be ordered through the GE accessory catalog:

- MDP CE (E46001BB), certified IEC 61439-1,

- MDP UL (E46001BD), certified UL508A for USA and OSPHD.



**The Customer MDP is not covered by the GE HealthCare product certification. The association of the Allia™ System and the Customer MDP is not covered by the GE HealthCare product certification.**

**GE specifically disclaims any and all liability arising out of or relating to the use or performance of the MDP and the cables in the scope of the System Pre-Installation Manual, including, and without limitation, any liability or claims relating to patient injury, death, or the reliability of such MDP.**

**The mechanical and electrical installation of the MDP is fully under the customer and the installer responsibility.**

**The customer is responsible for ensuring that all requirements from the System Pre-Installation Manual are met.**

### 5.4.1.2 Pre-Installation

It is the customer responsibility to ensure that the MDP and its input and output cables are installed prior to the GE equipment (PDU or X-PDU, other cabinets, 20 kVA Fluoro UPS option, etc.) to ensure that standard GE Service Process can be followed during the System installation. The connection of the MDP to the GE equipment shall only be made in presence of a GE Service representative.

It is recommended that the vendor contacts GE Service representative and reviews the site planning details before the MDP is installed.



#### NOTE

GE will not be responsible for any delay in installation if the MDP is not mounted and its cables not routed before GE parts arrive on site.

### 5.4.1.3 Spare Parts

The customer is responsible for providing and replacing any part of MDP.

## 5.4.2 Mandatory Construction Requirements

### 5.4.2.1 Input Power

The MDP shall be functional within one the following input voltage and frequency ranges from the Hospital mains:

- Voltage range for systems without the 20 kVA Fluoro UPS:
  - 380 V +/-10% 3~, 50 Hz or 60 Hz +/-3 Hz
  - 400 V +/-10% 3~, 50 Hz or 60 Hz +/-3 Hz
  - 415 V +/-10% 3~, 50 Hz or 60 Hz +/-3 Hz
  - 440 V +/-10% 3~, 50 Hz or 60 Hz +/-3 Hz
  - 480 V +/-10% 3~, 60 Hz +/-3 Hz
- Voltage range for systems with the 20 kVA Fluoro UPS:
  - 380 V +/-10% 3N~, 50 Hz or 60 Hz +/-3 Hz
  - 400 V +/-10% 3N~, 50 Hz or 60 Hz +/-3 Hz
  - 415 V +/-10% 3N~, 50 Hz or 60 Hz +/-3 Hz
  - 480 V +/-10% 3N~, 60 Hz +/-3 Hz

### 5.4.2.2 Breakers

The MDP shall provide a main breaker at its input, its specifications shall be:

- Current Rating: 100 A.
- It shall be capable of withstanding an inrush current of 2000 A for 10 ms.
- The voltage rating shall be the MDP nominal input line voltage +10%: i.e., 380 V + 10%, 400 V + 10%, 415 V + 10%, 440 V + 10% or 480 V +10%.
- The frequency range shall be adapted to the input line frequency i.e., 50 Hz+/-3 Hz or 60 Hz +/-3 Hz.
- The Short Circuit Current Rating (SCCR) shall be adapted to the input line source short circuit capacity.

This command of this breaker shall be accessible from the outside of the MDP, in order to be able to rearm it without opening the MDP after an emergency power off.

For systems with the 20 kVA Fluoro UPS, the MDP shall provide a second breaker for protection of the 20 kVA Fluoro UPS input. Its specifications shall be:

- 3 poles type
- Voltage rating: same as the MDP main breaker
- Frequency range: same as the MDP main breaker
- Current Rating: 50 A
- Short Circuit Current Rating (SCCR): 20 kA

For systems with the 20 kVA Fluoro UPS, the breaker for the 20 kVA Fluoro UPS input protection shall be powered by the MDP main breaker.

### 5.4.2.3 Terminal Blocks

The MDP shall have an input mains terminal block rated in accordance with the hospital input voltage. It shall be capable of holding minimum 35 mm<sup>2</sup> / 2 AWG cable for the 3 phases, protective Earth and neutral (only for systems with the 20 kVA Fluoro UPS).

The MDP shall provide an output terminal block rated in accordance with the MDP input voltage to connect the output from the MDP main breaker to the system. This terminal block shall be capable of holding minimum 35 mm<sup>2</sup> / 2 AWG cable for the 3 phases.

For systems with the 20 kVA Fluoro UPS, the MDP shall have a terminal block to connect an input neutral from the mains and an output neutral to the 20 kVA Fluoro UPS, and it shall have an output terminal block rated to the hospital input voltage to connect the mains input power from the MDP to the 20 kVA Fluoro UPS. This terminal block shall be capable of holding minimum 10 mm<sup>2</sup> / 6 AWG cable for the 3 phases and neutral.

### 5.4.2.4 Protective Earth

The MDP shall have a ground bar / ground terminal to connect the protective Earth cables:

- from the hospital mains,
- to the system,
- to the 20 kVA Fluoro UPS (if present).

### 5.4.2.5 Indicators

The MDP shall have lights to indicate the presence of voltage. The presence of voltage on each input line shall be indicated by at least having lamps between Line1-Line2 and Line2-Line3. The recommended color for these lamps is green.

### 5.4.3 Mandatory EPO Requirements

The MDP shall provide an emergency power off (EPO) button on its front.

The EPO button shall not be of momentary type.

The EPO button shall have 2 NC contacts:

- one NC contact is to trip the MDP input breaker,
- the other NC contact is to activate the UPS EPO input (8 kVA or 11 kVA or 20 kVA Fluoro UPS) to turn off the UPS output (this connection is done inside the PDU or X-PDU).

The MDP shall provide a terminal block to connect external cables to the 2 NC contacts of the MDP EPO.

When the MDP EPO or the PDU EPO is pressed, the MDP shall not provide any output voltage without any additional action on the EPO buttons and on the MDP input breaker.

The EPO button shall be protected against accidental activation, in order to prevent from accidental power OFF as shown below or equivalent.

**Figure 5-10 EPO Button**



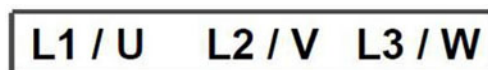
### 5.4.4 Mandatory LOTO Requirements

The MDP shall provide means of disconnecting the mains power from the system, with LOTO capability to ensure safe service operation. It can be done by the input breaker if it has disconnecting capability, or by a separate disconnection device.

An operator should be able to apply LOTO without opening the MDP box. When a LOTO device is installed on the MDP input breaker or on the disconnecting device, there shall be no voltage at the output of the MDP.

### 5.4.5 Mandatory Labeling Requirements

The input mains terminal block and the output terminal blocks of the MDP shall be labeled to indicate the 3 lines as shown below or equivalent:



For systems with the 20 kVA Fluoro UPS, the MDP input neutral terminal block and the neutral output terminal block to the 20 kVA Fluoro UPS shall be labelled with the IEC 60445 symbol as shown below or equivalent:



The ground bar shall be marked with the IEC 60417-5019 symbol as shown below:



### 5.4.6 Other Mandatory Requirements

The MDP and the external cables shall be compliant to all applicable local regulations, in particular to the standards applicable to Industrial Control Panels or Low-voltage switch gear and control gear assemblies, such as UL508A for USA or IEC 61439-1 for Europe.

The MDP enclosure shall be grounded if its enclosure is metallic, and there shall be no access to hazardous voltages. The enclosure shall provide enough rigidity to avoid hazardous situations in case of shock or impact and shall be designed in accordance with the local regulations.

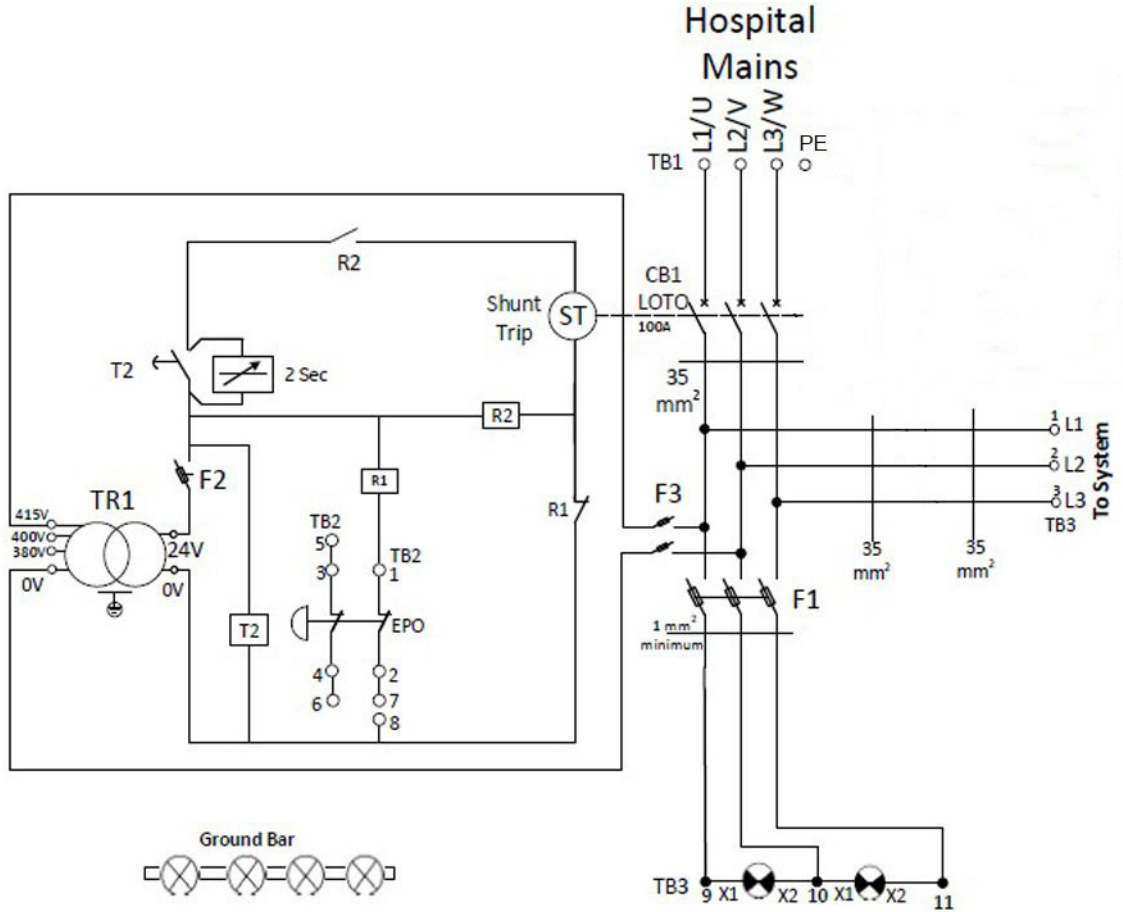
Local regulation may require the MDP to have a door interlock mechanism to prevent from opening the door when the main breaker is on.

The MDP shall be provided with a LOTO procedure.

## 5.4.7 Preferred Schematics and Components

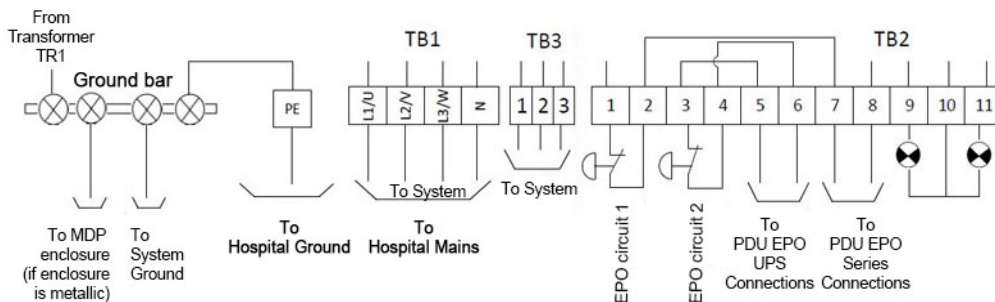
### 5.4.7.1 Recommended CE Schematics

Figure 5-11 11 kVA Fluoro UPS - CE MDP - Power and Control



**NOTE**  
 Neutral is not required by Imaging system.

Figure 5-12 11 kVA Fluoro UPS - CE MDP - I/O Interfaces





### 5.4.7.2 Minimum Components Specifications for the CE MDP

Table 5-4 11 kVA Fluoro UPS

Component	Label (refer to Figure 5-11 11 kVA Fluoro UPS - CE MDP - Power and Control on page 163)	Rating
Input Circuit Breaker	CB1	4 Pole, 100A, 20 kA SCCR and adapted to the input line, Vin + 10% 50 Hz or 60 Hz 2000 A inrush current withstand capability for at least 10 ms
Circuit Breaker	CB2	50 A, 20 kA SCCR, Vin+ 10%, 50 Hz or 60 Hz
Fuse	F1	2A Time delay, Vin+10% Based on green indicator lights power ratings
Fuse	F2	2A, 24 VAC+10% Based on transformer power rating and transformer load current rating
Fuse	F3	1A Time delay, Vin+10% Based on transformer power rating and transformer input current
Time delay relay	T2	24 VAC+10% Shall have 1 NO contact Time delay setting shall be min 2 Sec
Auxiliary relay	R1, R2*	24 VAC+10% Shall have 1 NC contact, 1 NO contact * R1 and R2 part numbers shall be identical (same manufacturer, same reference) Preferred components for R1 and R2 relay are: <ul style="list-style-type: none"> <li>• <b>GE HealthCare:</b> PRC1S13-BDL</li> <li>• <b>ABB:</b> CR-M024AC2L</li> <li>• <b>Schneider Electric:</b> 782XBXM4L-24A</li> <li>• <b>Omron:</b> MK2PI</li> </ul>
Shunt Trip	ST	24 VAC+10% Shunt trip opens the MDP input main breaker when the shunt trip is energized
2 Pilot lights Green	-	Vin+10%, 50 Hz or 60 Hz
Transformer	TR1	Power rating: 50 VA or based on power ratings of components used at transformer output Input: 380 VAC or 400 VAC or 415 VAC or 440 VAC Output: 24V Frequency: 50 or 60 Hz Double insulation as per standard IEC61558 The sum of power ratings of R1, shunt trip and timer shall be less than transformer power rating

**Table 5-4 11 kVA Fluoro UPS** (Table continued)

Component	Label (refer to Figure 5-11 11 kVA Fluoro UPS - CE MDP - Power and Control on page 163)	Rating
EPO	-	Mushroom button with 2 NC contacts Rated for 24 VAC, 50 mA
Cable for MDP internal Control circuitry	-	Min 1 mm <sup>2</sup> and in accordance with the fuses rating

**Table 5-5 20 kVA Fluoro UPS**

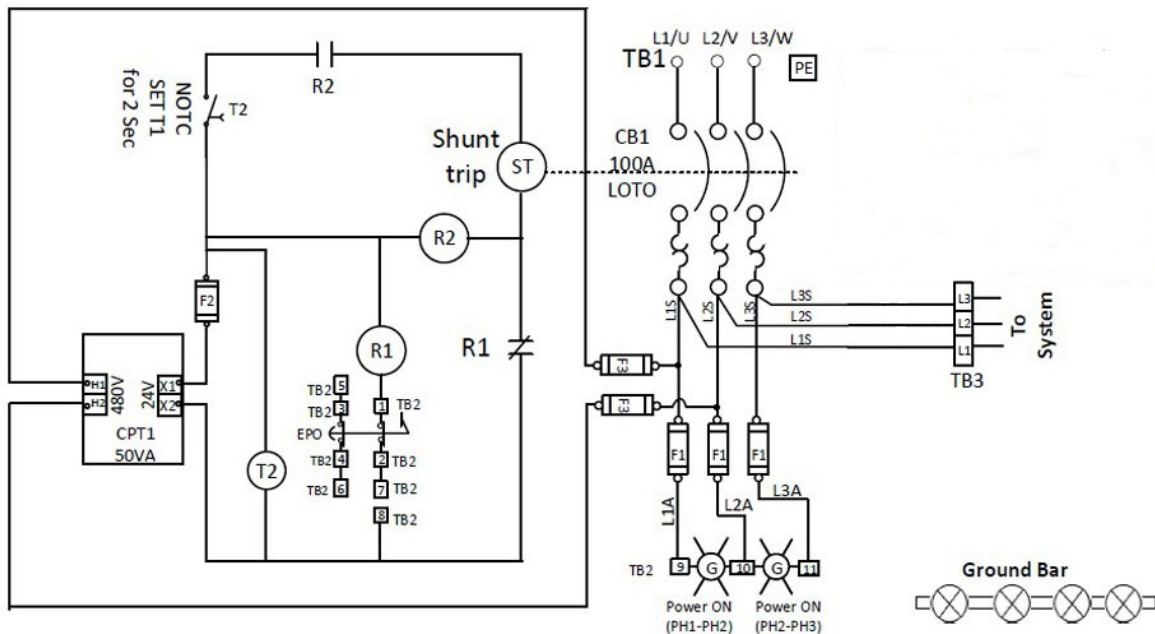
Component	Label (refer to Figure 5-13 20 kVA Fluoro UPS - CE MDP - Power and Control on page 164)	Rating
Input Circuit Breaker	CB1	4 Pole, 100A, 20 kA SCCR and adapted to the input line, Vin + 10% 50 Hz or 60 Hz 2000 A inrush current withstand capability for at least 10 ms
Circuit Breaker	CB2	50 A, 20 kA SCCR, Vin+ 10%, 50 Hz or 60 Hz
Fuse	F1	2A Time delay, Vin+10% Based on green indicator lights power ratings
Fuse	F2	2A, 24 VAC+10% Based on transformer power rating and transformer load current rating
Fuse	F3	1A Time delay, Vin+10% Based on transformer power rating and transformer input current
Time delay relay	T2	24 VAC+10% Shall have 1 NO contact Time delay setting shall be min 2 Sec
Auxiliary relay	R1, R2*	24 VAC+10% Shall have 1 NC contact, 1 NO contact * R1 and R2 part numbers shall be identical (same manufacturer, same reference) Preferred components for R1 and R2 relay are: <ul style="list-style-type: none"> <li>• <b>GE:</b> PRC1S13-BDL</li> <li>• <b>ABB:</b> CR-M024AC2L</li> <li>• <b>Schneider Electric:</b> 782XBXM4L-24A</li> <li>• <b>Omron:</b> MK2PI</li> </ul>

**Table 5-5 20 kVA Fluoro UPS (Table continued)**

Component	Label (refer to Figure 5-13 20 kVA Fluoro UPS - CE MDP - Power and Control on page 164)	Rating
Shunt Trip	ST	24 VAC+10% Shunt trip opens the MDP input main breaker when the shunt trip is energized
2 Pilot lights Green	-	Vin+10%, 50 Hz or 60 Hz
Transformer	TR1	Power rating: 50 VA or based on power ratings of components used at transformer output Input: 380 VAC or 400 VAC or 415 VAC or 440 VAC Output: 24V Frequency: 50 or 60 Hz Double insulation as per standard IEC61558 The sum of power ratings of R1, shunt trip and timer shall be less than transformer power rating
EPO	-	Mushroom button with 2 NC contacts Rated for 24 VAC, 50 mA
Cable for MDP internal Control circuitry	-	Min 1 mm <sup>2</sup> and in accordance with the fuses rating

### 5.4.7.3 Recommended UL Schematics

**Figure 5-15 11 kVA Fluoro UPS - UL MDP - Power and Control**



**NOTE**  
Neutral is not required by Imaging system.

Figure 5-16 11 kVA Fluoro UPS - UL MDP - I/O Interfaces

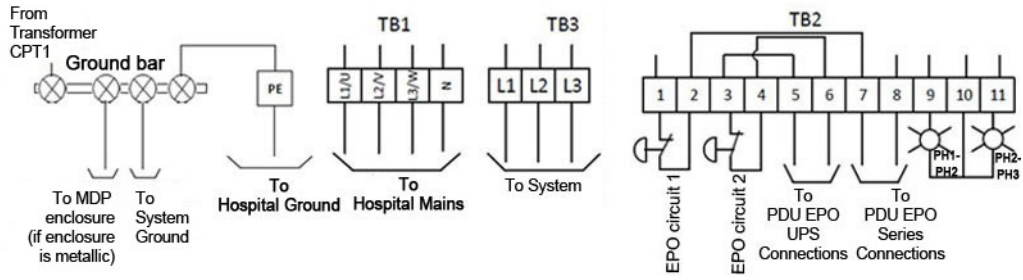
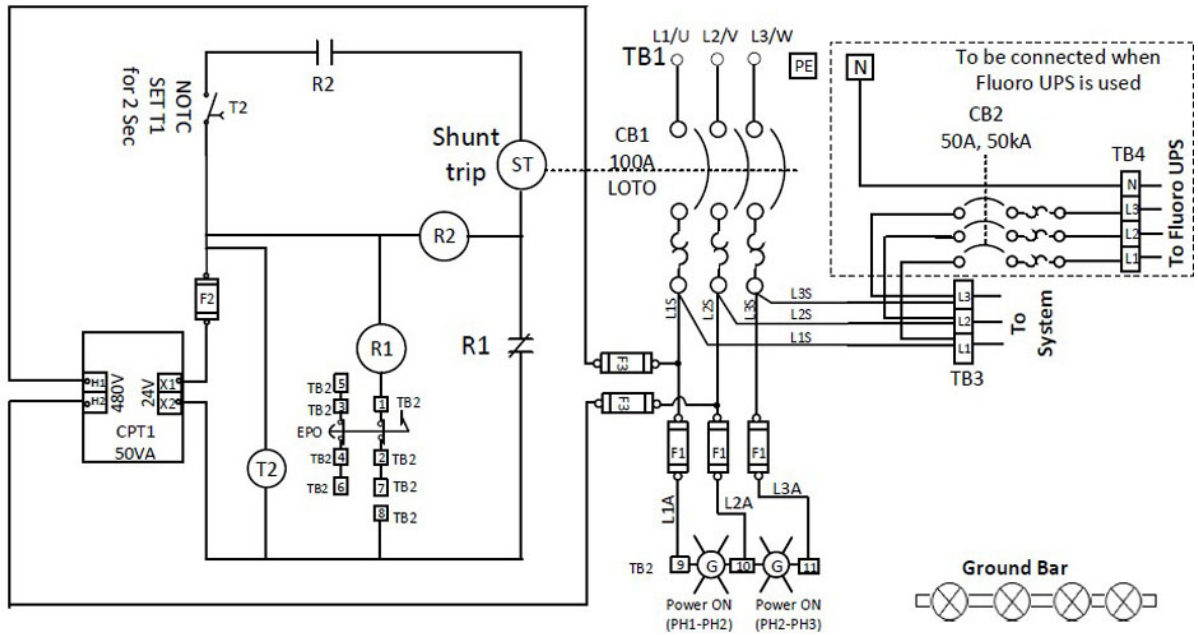
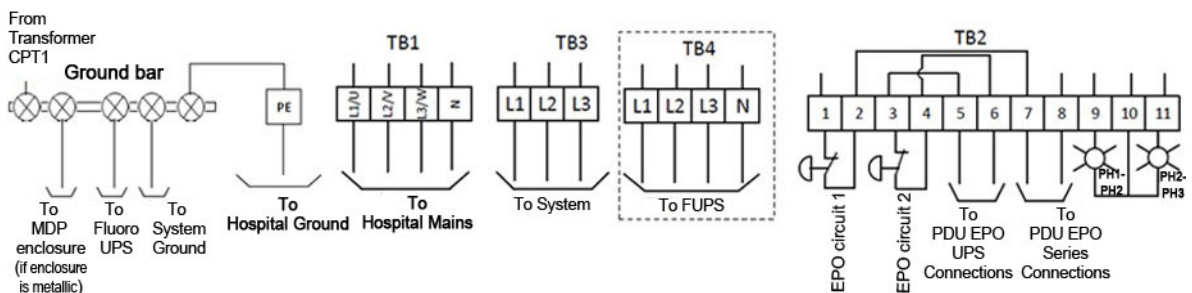


Figure 5-17 20 kVA Fluoro UPS - UL MDP - Power and Control



**NOTE**  
 Neutral is not required by Imaging system.  
 Neutral is required when 20 kVA Fluoro UPS is used.

Figure 5-18 20 kVA Fluoro UPS - UL MDP - I/O Interfaces



## 5.4.7.4 Minimum Components Specifications for the UL MDP

Table 5-6 11 kVA Fluoro UPS

Component	Label (refer to Figure 5-15 11 kVA Fluoro UPS - UL MDP - Power and Control on page 167)	Rating
Input Circuit Breaker	CB1	3 Pole, 100 A, 20 kA SCCR and adapted to the input line, 480 VAC+10% 60 Hz 2000 A inrush current withstand capability for at least 10 ms
Circuit Breaker	CB2	50 A, 20 kA SCCR, 480 VAC+10%
Fuse	F1	2A Time delay, 480 VAC+10% Based on green indicator lights power ratings
Fuse	F2	2A, 24 VAC+10% Based on transformer power rating and transformer load current rating
Fuse	F3	1A Time delay, 480 VAC+10% Based on transformer power rating and transformer input current
Time delay relay	T2	24 VAC+10% Shall have 1 NO contact Time delay setting shall be min 2 s
Auxiliary relay	R1, R2*	24 VAC+10% Shall have 1 NC contact, 1 NO contact * R1 and R2 part numbers shall be identical (same manufacturer, same reference) Preferred components for R1 and R2 relay are: <ul style="list-style-type: none"> <li>• <b>GE HealthCare:</b> PRC1S13-BDL</li> <li>• <b>ABB:</b> CR-M024AC2L</li> <li>• <b>Schneider Electric:</b> 782XBXM4L-24A</li> <li>• <b>Omron:</b> MK2PI</li> </ul>
Shunt Trip	ST	24 VAC+10% Shunt trip shall open the MDP input breaker when shunt trip is energized
2 Pilot lights Green	PH1-PH2 PH2-PH3	480 VAC +10%

**Table 5-6 11 kVA Fluoro UPS** (Table continued)

Component	Label (refer to Figure 5-15 11 kVA Fluoro UPS - UL MDP - Power and Control on page 167)	Rating
Transformer	CP T1	Power rating: 50 VA or based on power ratings of components used at transformer output Input: 480 VAC Output: 24 VAC Frequency: 60 Hz +/-3 Hz Double insulation as per UL 5085-1 standard The sum of power ratings of R1, shunt trip and timer shall be less than transformer power rating
EPO	-	Mushroom button with 2 NC contacts Rated for 24 VAC, 50 mA
Cable for MDP internal Control circuitry	-	Min 16 AWG and in accordance with the fuses rating

**Table 5-7 20 kVA Fluoro UPS**

Component	Label (refer to Figure 5-17 20 kVA Fluoro UPS - UL MDP - Power and Control on page 168)	Rating
Input Circuit Breaker	CB1	3 Pole, 100 A, 20 kA SCCR and adapted to the input line, 480 VAC+10% 60 Hz 2000 A inrush current withstand capability for at least 10 ms
Circuit Breaker	CB2	50 A, 20 kA SCCR, 480 VAC+10%
Fuse	F1	2A Time delay, 480 VAC+10% Based on green indicator lights power ratings
Fuse	F2	2A, 24 VAC+10% Based on transformer power rating and transformer load current rating
Fuse	F3	1A Time delay, 480 VAC+10% Based on transformer power rating and transformer input current
Time delay relay	T2	24 VAC+10% Shall have 1 NO contact Time delay setting shall be min 2 s

**Table 5-7 20 kVA Fluoro UPS** (Table continued)

Component	Label (refer to Figure 5-17 20 kVA Fluoro UPS - UL MDP - Power and Control on page 168)	Rating
Auxiliary relay	R1, R2*	24 VAC+10% Shall have 1 NC contact, 1 NO contact * R1 and R2 part numbers shall be identical (same manufacturer, same reference) Preferred components for R1 and R2 relay are: <ul style="list-style-type: none"> <li>• <b>GE:</b> PRC1S13-BDL</li> <li>• <b>ABB:</b> CR-M024AC2L</li> <li>• <b>Schneider Electric:</b> 782XBXM4L-24A</li> <li>• <b>Omron:</b> MK2PI</li> </ul>
Shunt Trip	ST	24 VAC+10% Shunt trip shall open the MDP input breaker when shunt trip is energized
2 Pilot lights Green	PH1-PH2 PH2-PH3	480 VAC +10%
Transformer	CP T1	Power rating: 50 VA or based on power ratings of components used at transformer output Input: 480 VAC Output: 24 VAC Frequency: 60 Hz +/-3 Hz Double insulation as per UL 5085-1 standard The sum of power ratings of R1, shunt trip and timer shall be less than transformer power rating
EPO	-	Mushroom button with 2 NC contacts Rated for 24 VAC, 50 mA
Cable for MDP internal Control circuitry	-	Min 16 AWG and in accordance with the fuses rating

### 5.4.8 Checklist

The following checklist shall be filled and given to the Field Engineer before connecting the MDP to the system.

**Table 5-8**

Test	Expected Result	OK / NOK
Functional Tests		
Initial state: the MDP main breaker is off, power is available at its input. A jumper is installed between TB2 7 & 8 Turn on the MDP main breaker.	The indicator lights on MDP front panel are ON.	
	The voltage at TB3 is the same as the MDP input voltage.	

Table 5-8 (Table continued)

Test	Expected Result	OK / NOK
	For systems with the 20 kVA Fluoro UPS, the voltage at TB4 is the same as the MDP input voltage.	
Press the EPO push button on MDP front panel.	The indicator lights on the MDP front panel are turned off.	
	The MDP main breaker is opened.	
	There is no voltage at TB3.	
	For systems with the 20 kVA Fluoro UPS, there is no voltage at TB4.	
	The dry contact between TB2 5 & 6 is open.	
Check it is possible to apply the LOTO on the MDP input breaker or on the disconnecting device.	It is possible to apply the LOTO on the MDP input breaker or on the disconnecting device.	
Documentation		
Check a LOTO procedure is provided with the MDP.	The LOTO procedure is present.	
Components Ratings		
Check that the components ratings are compliant with the requirements of <a href="#">5.4.7.2 Minimum Components Specifications for the CE MDP on page 165</a> or <a href="#">5.4.7.4 Minimum Components Specifications for the UL MDP on page 169</a> .	The components ratings are compliant with the requirements of <a href="#">5.4.7.2 Minimum Components Specifications for the CE MDP on page 165</a> or <a href="#">5.4.7.4 Minimum Components Specifications for the UL MDP on page 169</a> .	

## 5.5 External Interfaces

All lights (system ON, X Ray and room) shall be installed according to local electrical regulation. In particular, requirements regarding back-up power of these lights shall be considered as they are not powered by GE HealthCare UPS.

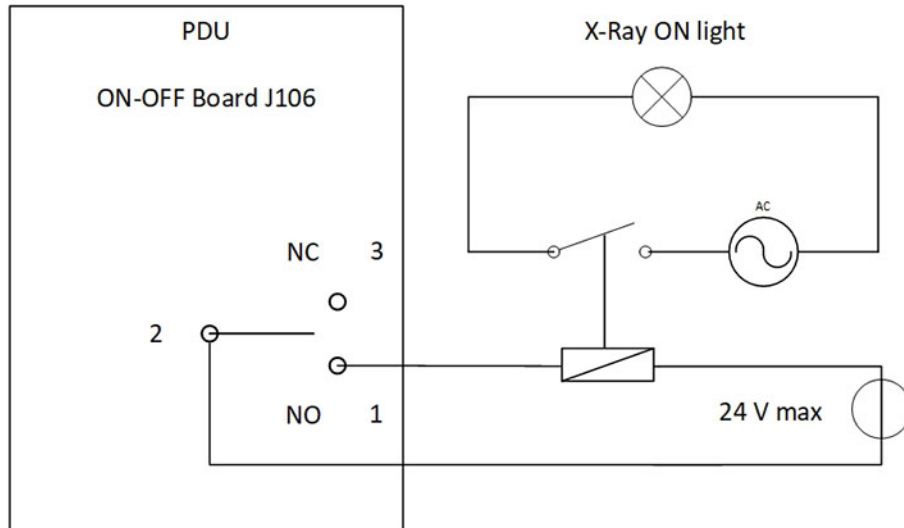
### 5.5.1 X-Ray ON lights

#### NOTICE

The X-Ray ON lamp must be installed in the Exam Room in conformity to the standard IEC/EN 60601-2-43. The X-Ray ON lamp shall be visible by the operator in all the locations defined for the personnel who may receive scattered radiation.

The system provides a dry contact to trigger a low voltage relay (24 V max) that drives the X-Ray ON lights. The customer is responsible for the procurement, delivery and installation of the power supplies, relay, cables and the X-Ray ON lights.

Figure 5-19

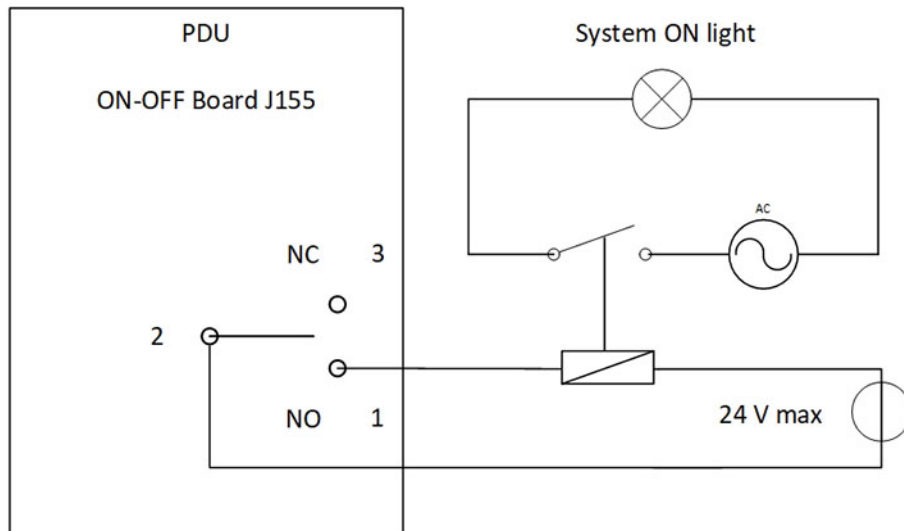


The cables are connected to the PDU on an open contact. The diameter of the cables shall be 2 mm<sup>2</sup> maximum.

### 5.5.2 System ON light

The system provides a dry contact to trigger a low voltage relay (24 V max) that can drive a System ON light. The customer is responsible for the procurement, delivery and installation of the power supplies, relay, cables and the System ON light.

Figure 5-20

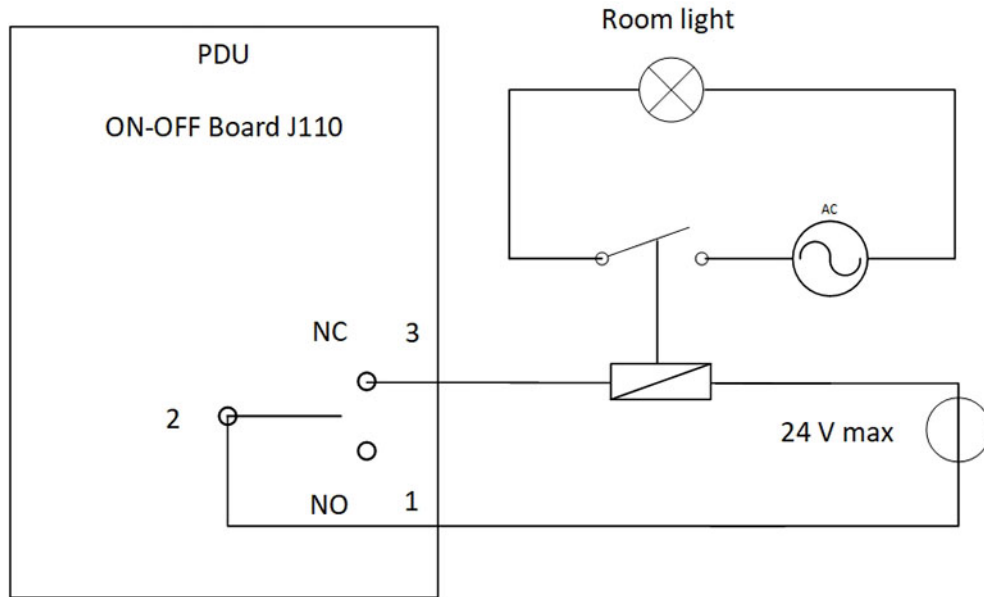


The cables are connected to the PDU on an open contact. The diameter of the cables shall be 2 mm<sup>2</sup> maximum.

### 5.5.3 Room lights

The system provides a dry contact to trigger a low voltage relay (24 V max) that can drive the Exam Room lights. The customer is responsible for the procurement, delivery and installation of the power supplies, relay, cables and the room lights.

**Figure 5-21**



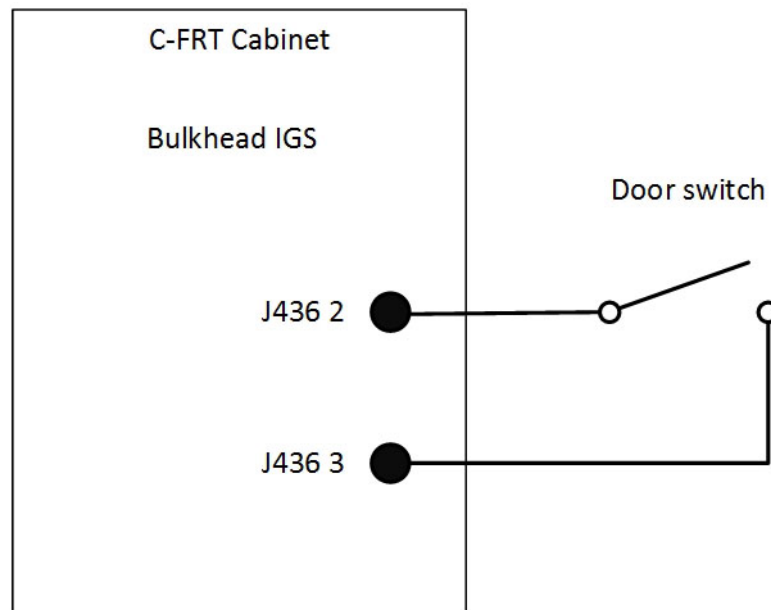
The cables are connected to the PDU on a closed contact. The diameter of the cables shall be 2 mm<sup>2</sup> maximum.

### 5.5.4 Room door interlock

The system provides a room door interlock that can prevent X-Ray emission when the door is open. The IEC 60601-2-43 requires not to install door interlocks. It is the responsibility of the installer to verify that the connection of this interlock is not in contradiction with local regulation. In case of conflict, the local regulation shall prevail.

This switch shall be closed when the door is closed, it shall be compatible with 24 V DC.

**Figure 5-22**



To disable the door interlock: the pins 2 and 3 from J436 shall be shorted. The diameter of the cables connected to the cabinet shall be 2 mm<sup>2</sup> maximum.

## 5.5.5 Video distribution

The system offers the possibility to export up to 4 video streams of the LDM image to:

- Medical grade monitors,
- ‘non- medical grade’ monitors for example for education purpose or for visibility to staff not performing the procedure,
- Video recording or broadcasting systems.

The monitor shall be provided and installed by the customer and shall not powered by the system.

The video streams are:

- 1 HDMI with fixed resolution 4k (3840 x 2160 60Hz),
- 1 HDM re-sized to the resolution of the connected monitor (up to 4k),
- 1 HDMI with fixed resolution Full HD (1920 X 1080 60Hz),
- 1 DVI with fixed resolution Full HD.

These video streams are provided through optional 30 meters optical extenders.

## 5.6 Additional Full UPS

If it is required to power continuously the system in record mode during power failure, a 150 kVA UPS can be used in front of the system. Such an UPS will provide to the customer about 10 minutes of autonomy. This UPS comes in addition to the UPS provided with the system.

In case the system is powered by a mains voltage of 380, 400 or 415Vac (50 or 60 Hz) it is also possible to use the UPS 93E-G2 120 kVA from Eaton (E45011ND) for this purpose.

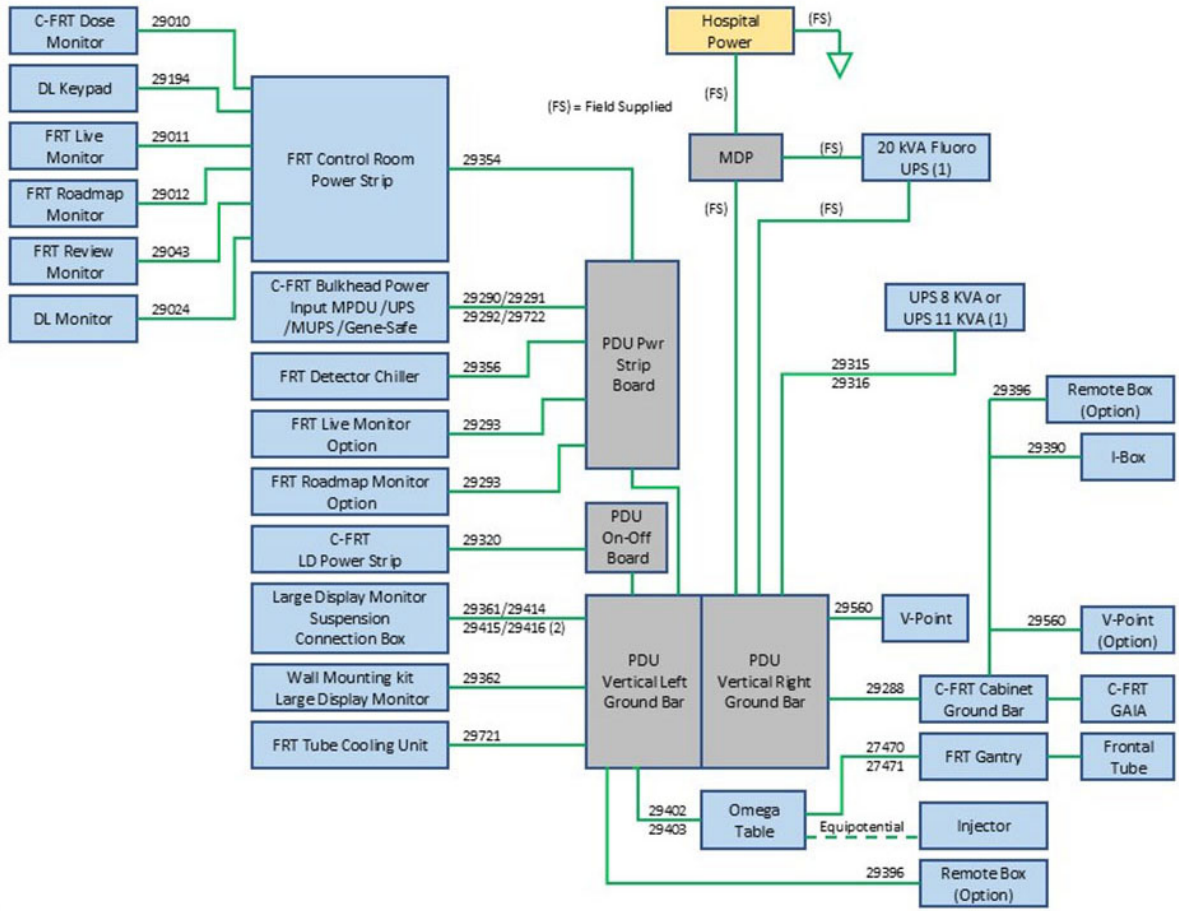
## 5.7 Grounding Schematics



### NOTE

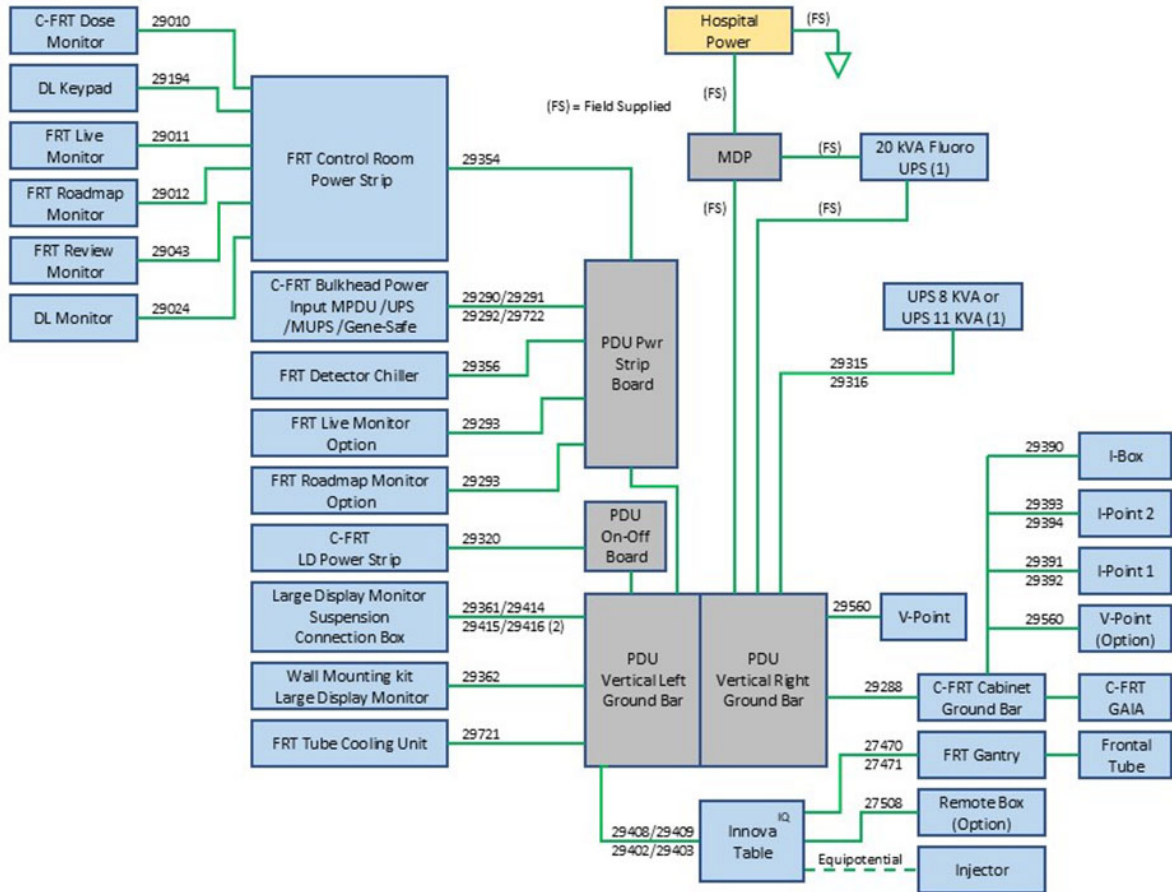
For Third party monitor suspension grounding, refer to [5.8 Third-Party Monitor Suspension Typical Connections on page 177](#).

Figure 5-23 System with Omega Table and Large Display Monitors



- (1) The system is provided with one UPS
- (2) MIS 29414, MIS 29415 and MIS 29416 are connected only with a Third-Party LDM suspension

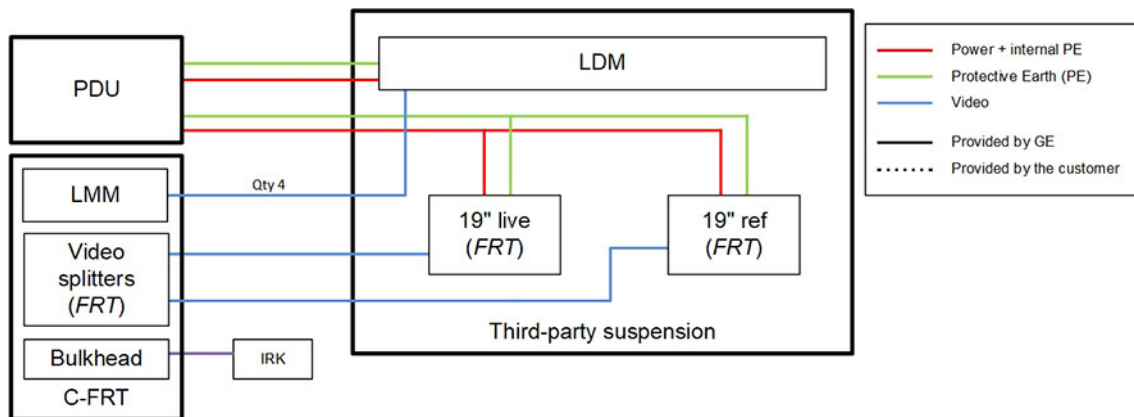
Figure 5-24 System with Innova IQ Table and Large Display Monitors



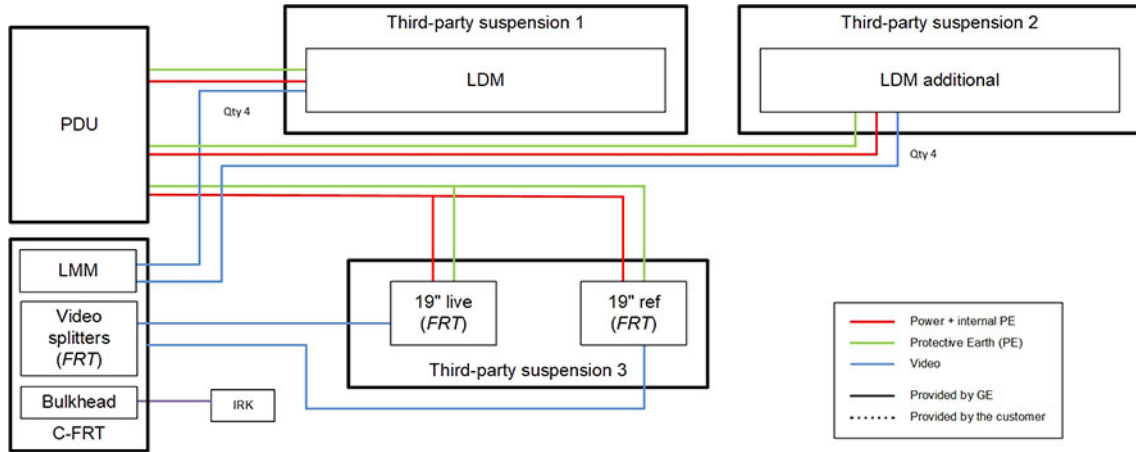
- (1) The system is provided with one UPS
- (2) MIS 29414, MIS 29415 and MIS 29416 are connected only with a Third-Party LDM suspension

## 5.8 Third-Party Monitor Suspension Typical Connections

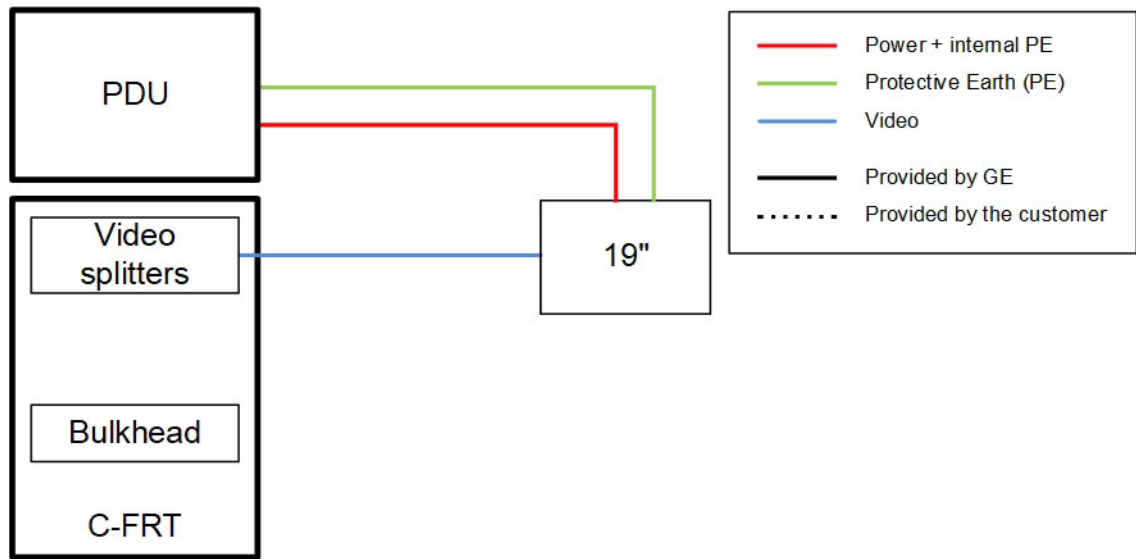
Figure 5-25 Typical connections for 1 LDM with the 19" backup monitors at the back of the LDM



**Figure 5-26 Typical connections for 2 LDM with 19" backup monitors on an additional suspension**



**Figure 5-27 Connection of the additional in-room 19" monitor**



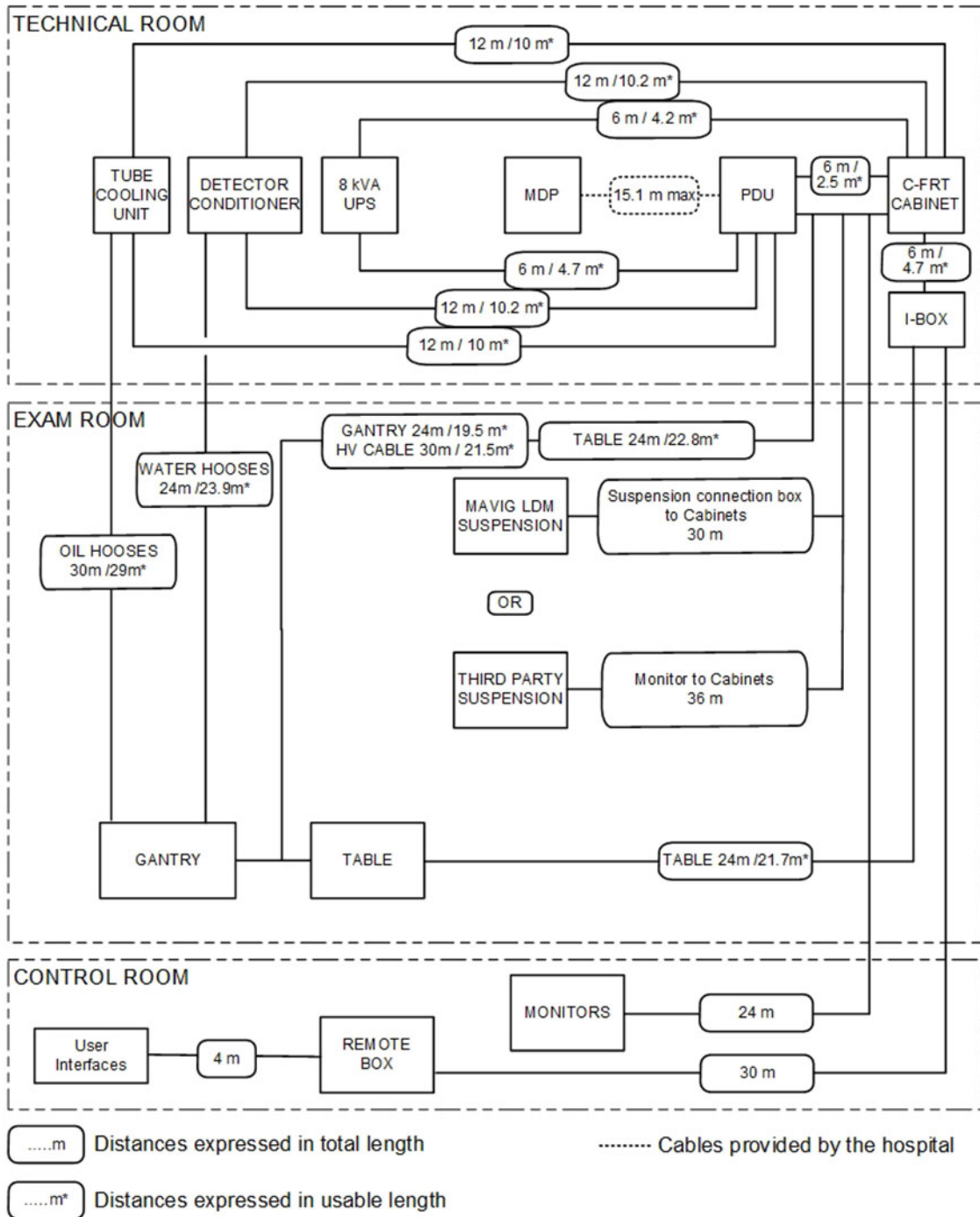
## 5.9 System Cable Information

### 5.9.1 Physical Runs

### 5.9.1.1 Physical Run Synoptic

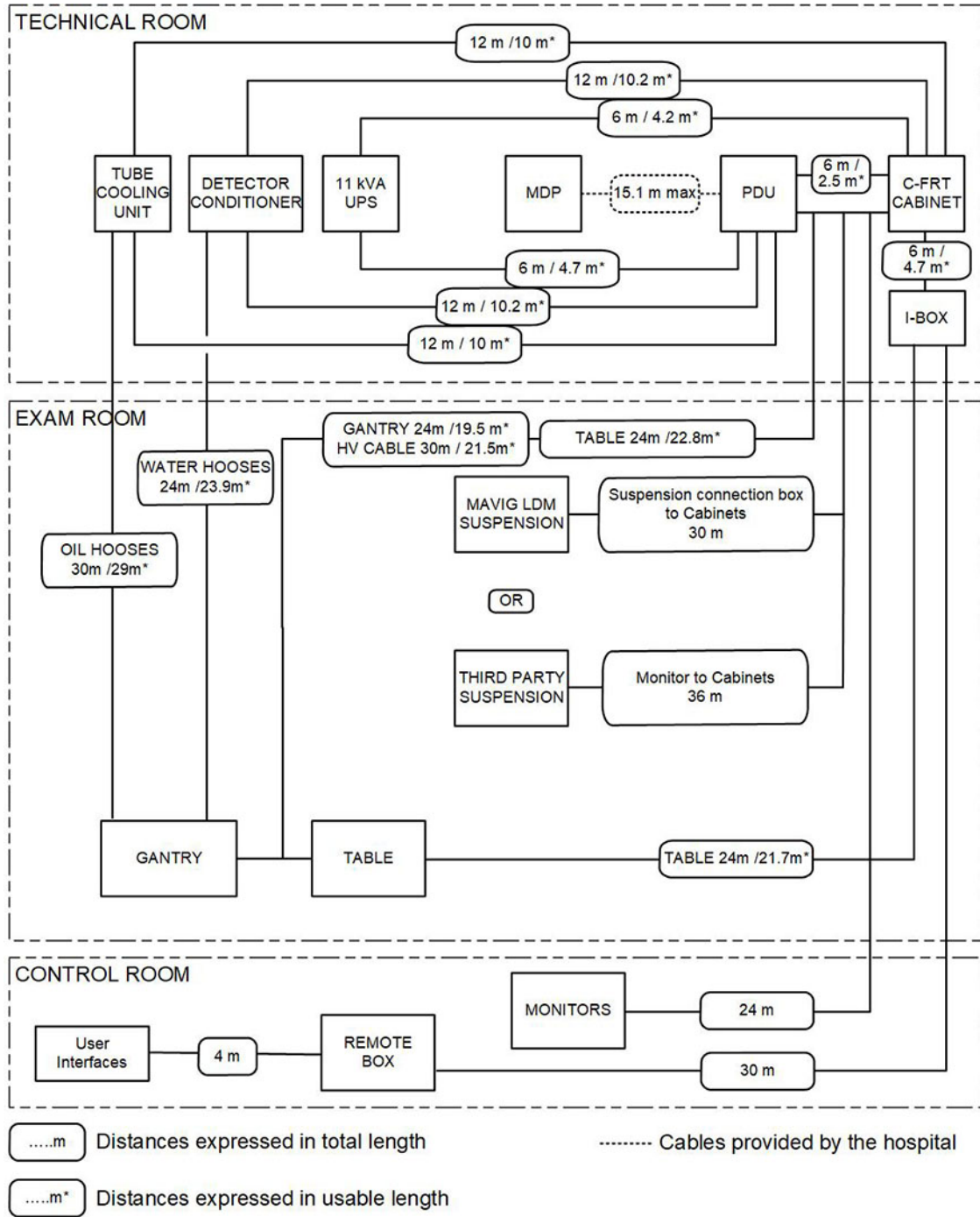
#### 5.9.1.1.1 System with Omega Table

Figure 5-28 (For Omega Table) Interconnection Length - System with 8 kVA UPS and PDU V2



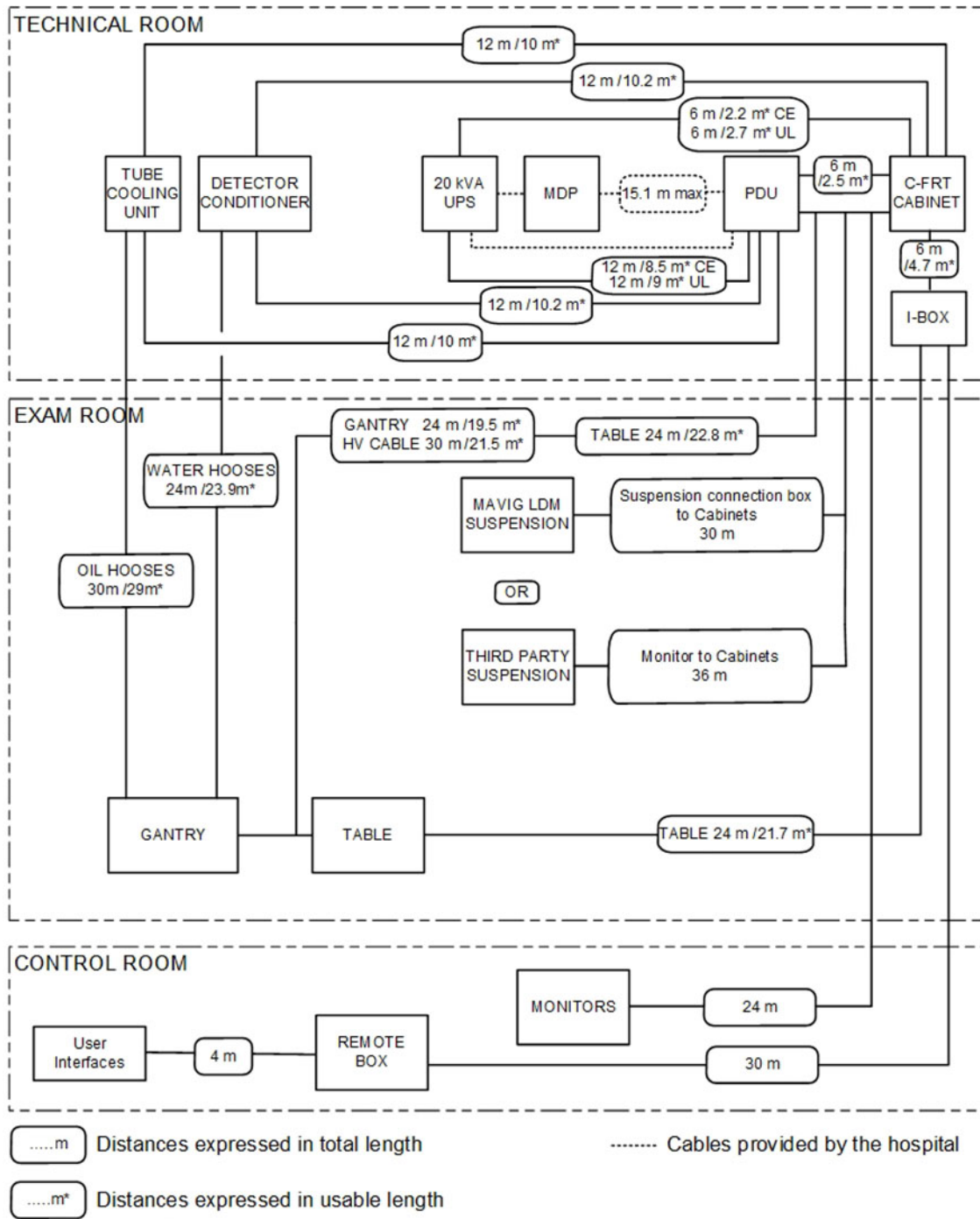
The routing of the HV cable shall respect a minimum bending radius of 92 mm.

**Figure 5-29 (For Omega Table) Interconnection Length - System with Fluoro UPS 11 kVA and X-PDU**



The routing of the HV cable shall respect a minimum bending radius of 92 mm.

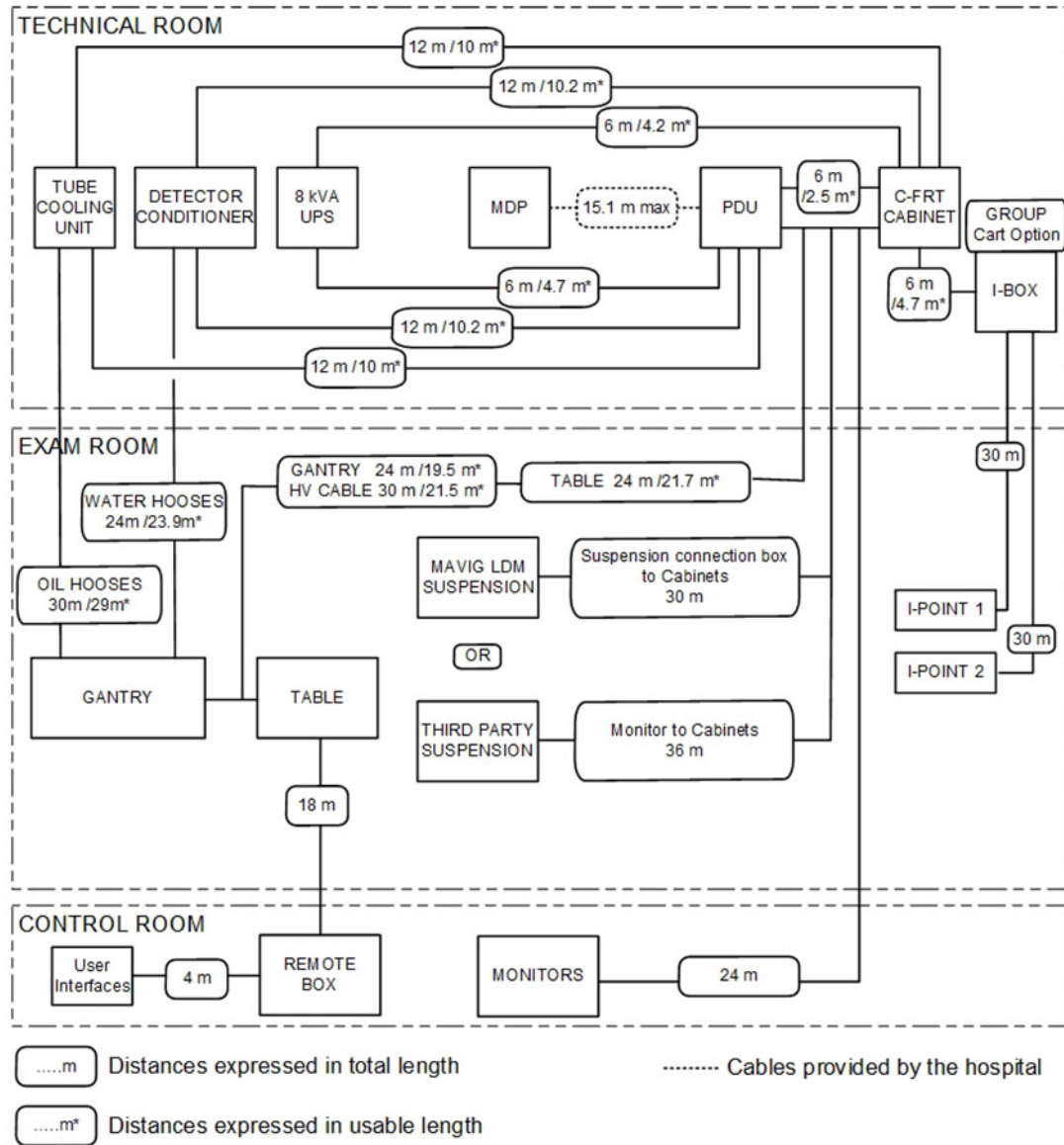
**Figure 5-30 (For Omega Table) Interconnection Length - System with 20 kVA UPS (Fluoro UPS) and PDU V2**



The routing of the HV cable shall respect a minimum bending radius of 92 mm.

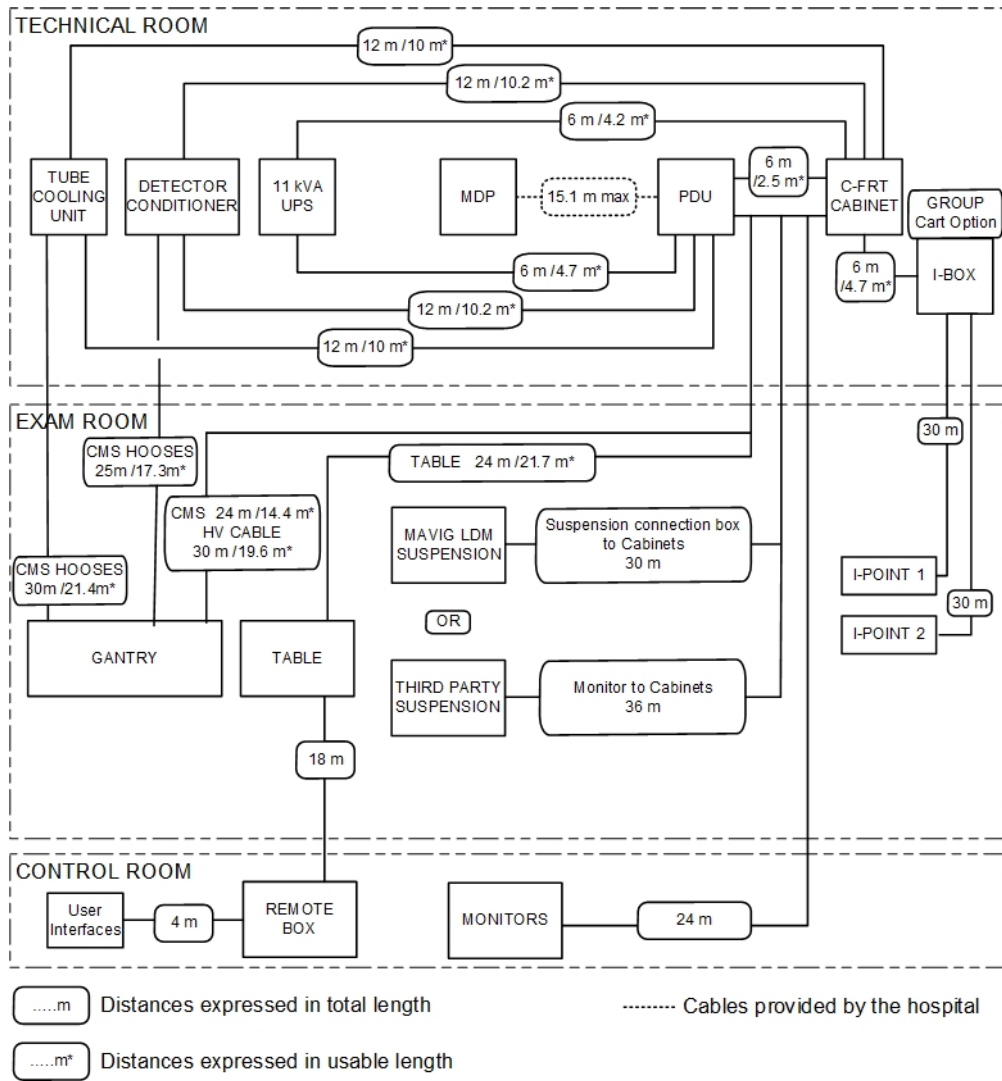
### 5.9.1.1.2 System with Innova<sup>IQ</sup> Table

Figure 5-31 (For Innova<sup>IQ</sup> Table) Interconnection Length - System with 8 kVA UPS and PDU V2



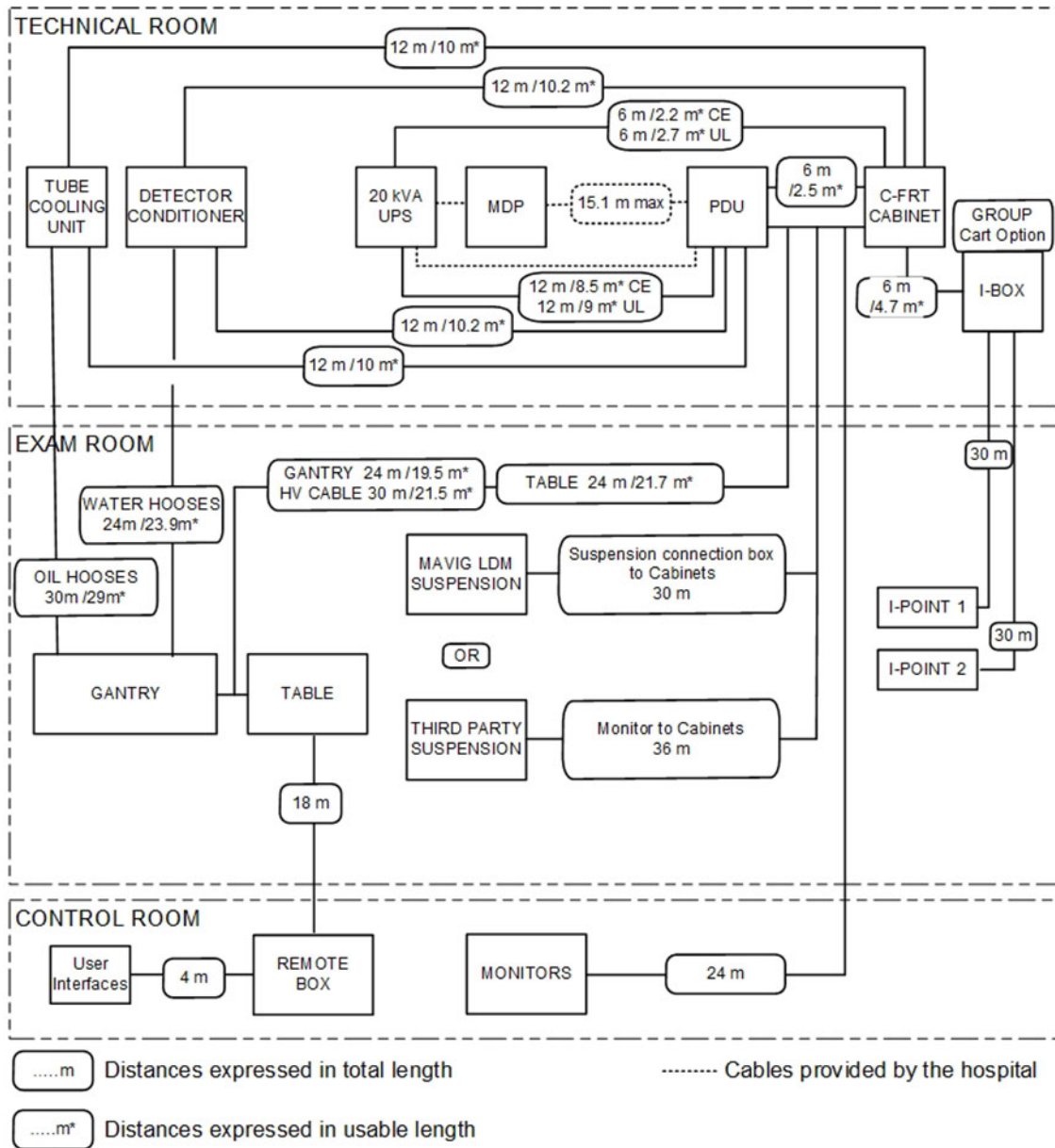
The routing of the HV cable shall respect a minimum bending radius of 92 mm.

**Figure 5-32 (For Innova<sup>IQ</sup> Table) Interconnection Length - System with Fluoro UPS 11 kVA and X-PDU**



The routing of the HV cable shall respect a minimum bending radius of 92 mm.

**Figure 5-33 (For Innova<sup>IQ</sup> Table) Interconnection Length - System with 20 KVA UPS (Fluoro UPS) and PDU V2**



The routing of the HV cable shall respect a minimum bending radius of 92 mm.

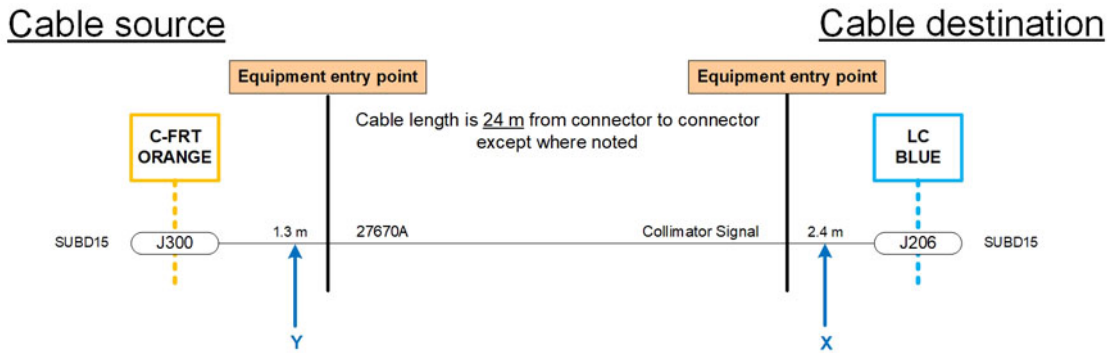
### 5.9.1.2 System Core Matrix

**NOTICE**

The equipment entry point for the PDU, C-FRT & 20 kVA Fluoro UPS is considered to be on the floor, in the middle of the rear face of each cabinet.

For a description of how to use the following cable group schematics, see below:

**Figure 5-34 Example of cables schematic**



Cable length data is as follows:

- **Cable Length** = the total cable length, connector to connector (example above is 24 meters).
- **X + Y** = used length for connection within system (example above is 3.7 meters).
- **Cable Length - (X + Y)** = available length for conduit run (example above is 20.3 meters).

Figure 5-35 (For System with Omega Table) From Technical Room to Exam Room

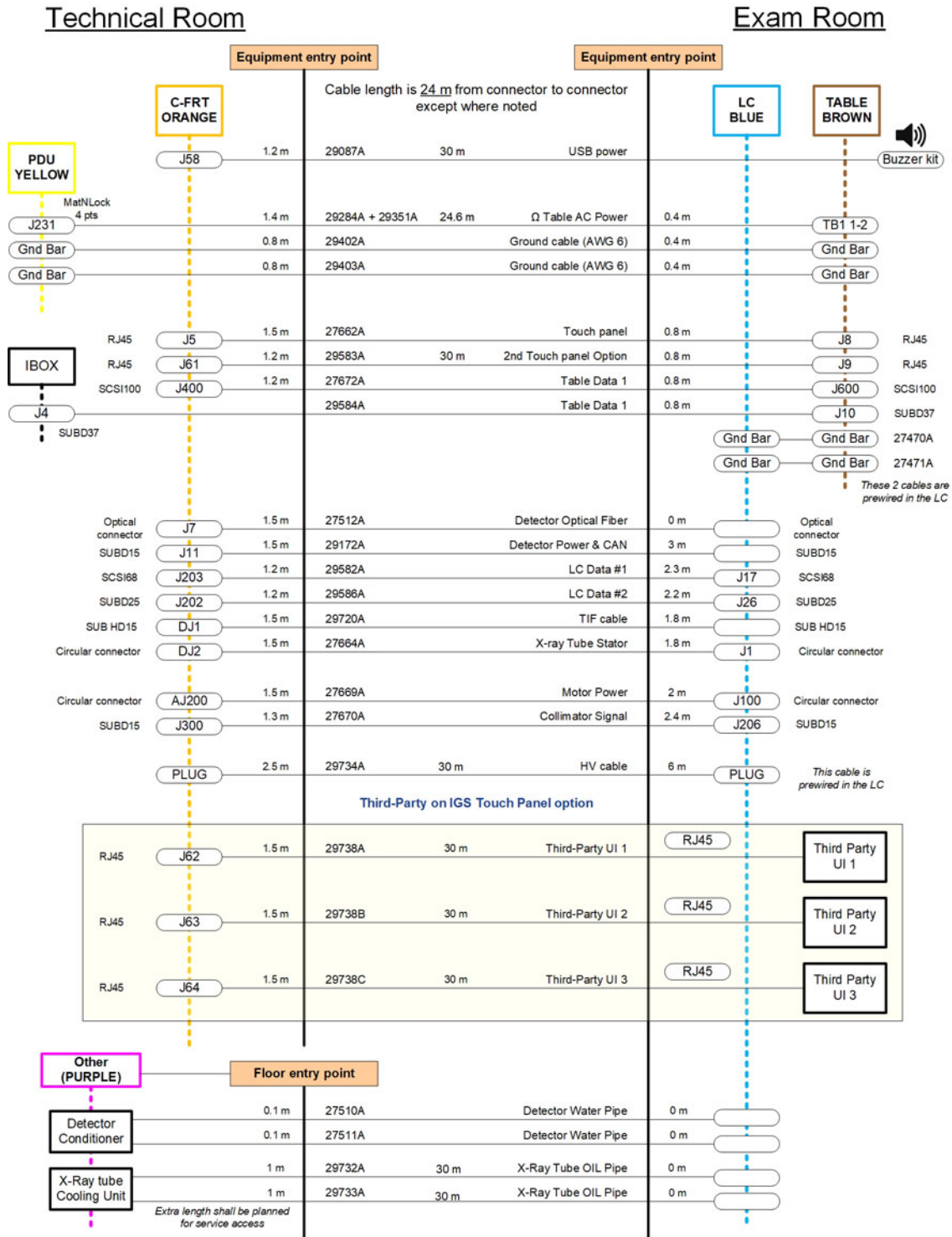




Figure 5-37 From Technical Room to Control Room

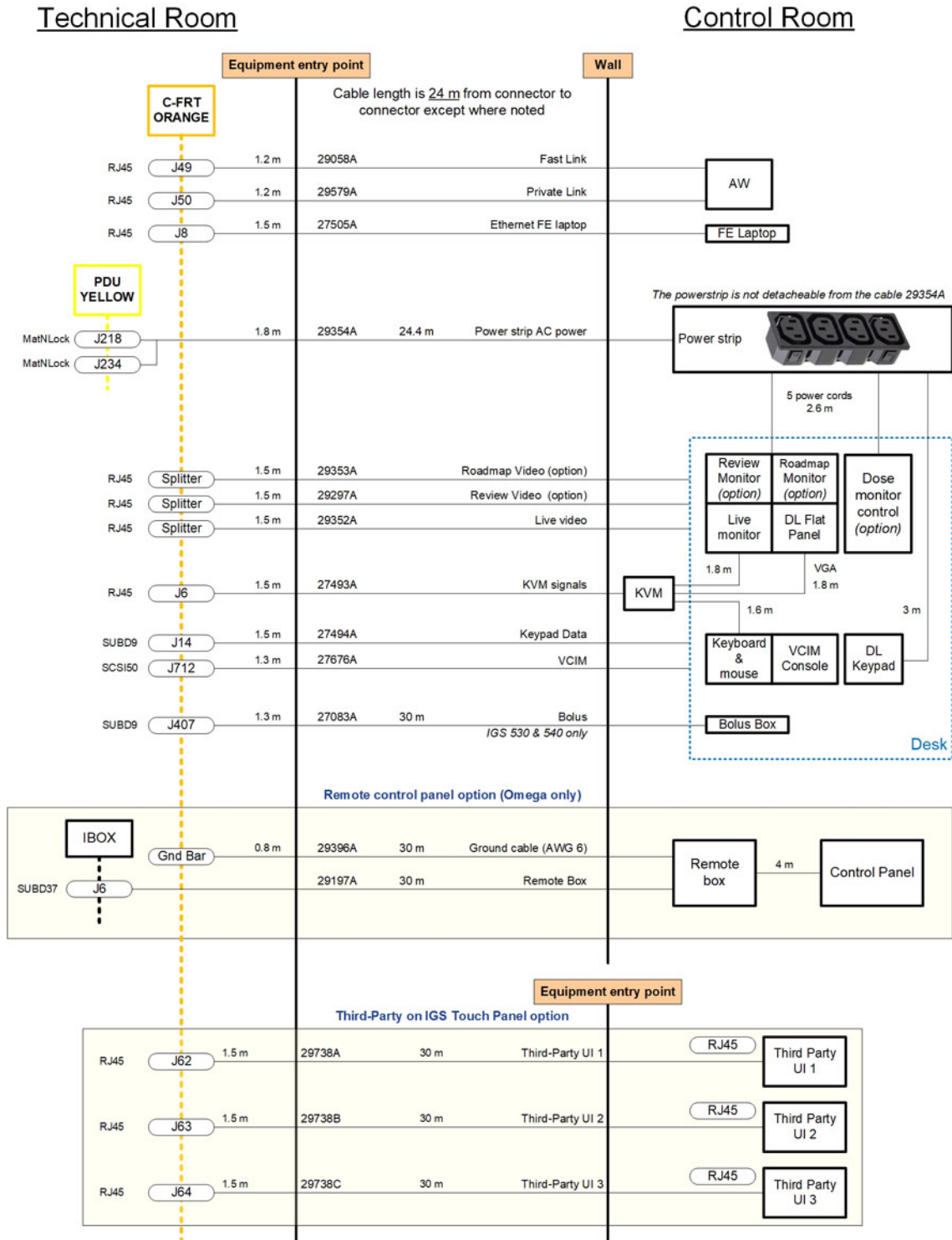
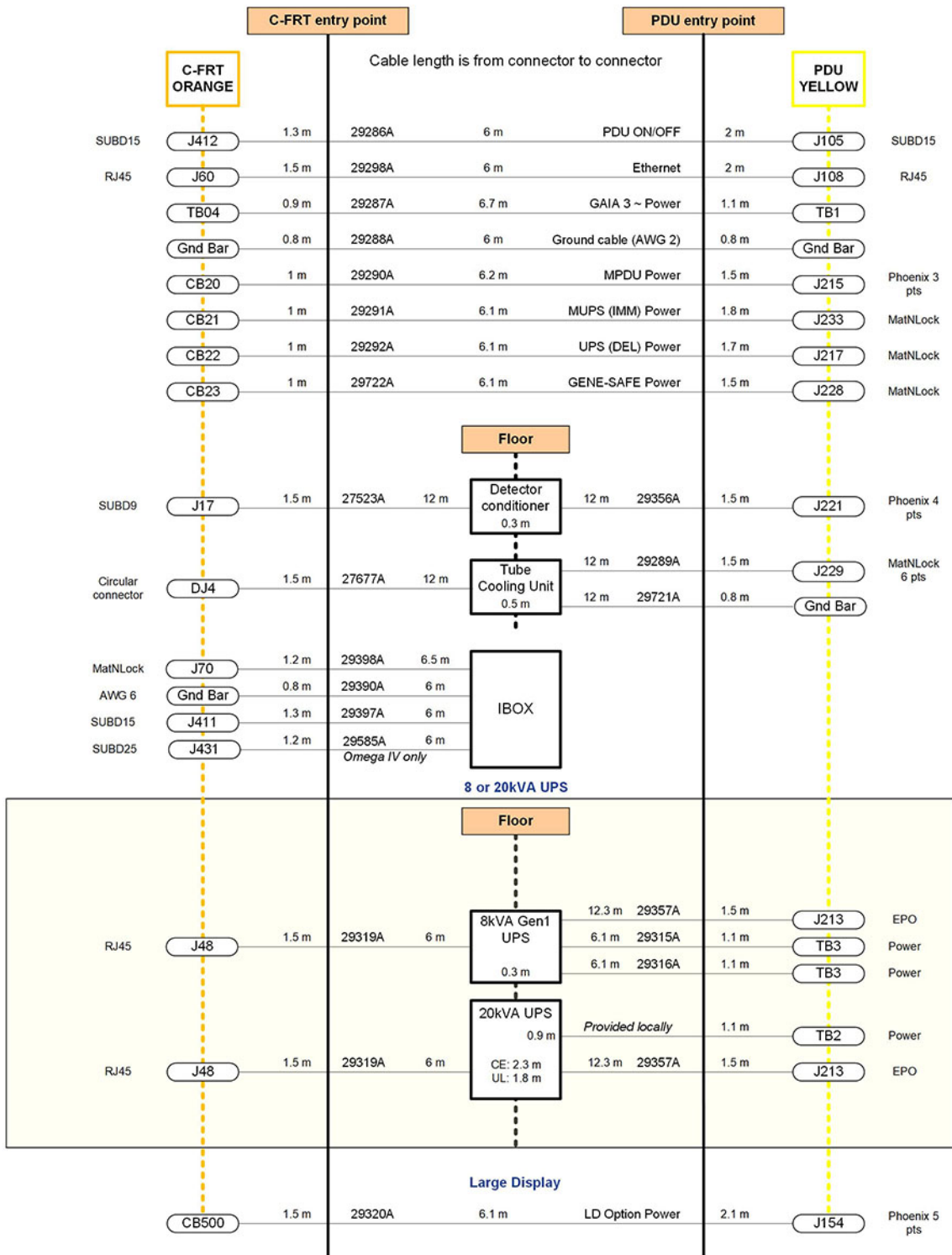


Figure 5-38 (For System with Omega Table) From Technical Room to Technical Room with PDU V2

Technical Room



# Technical Room

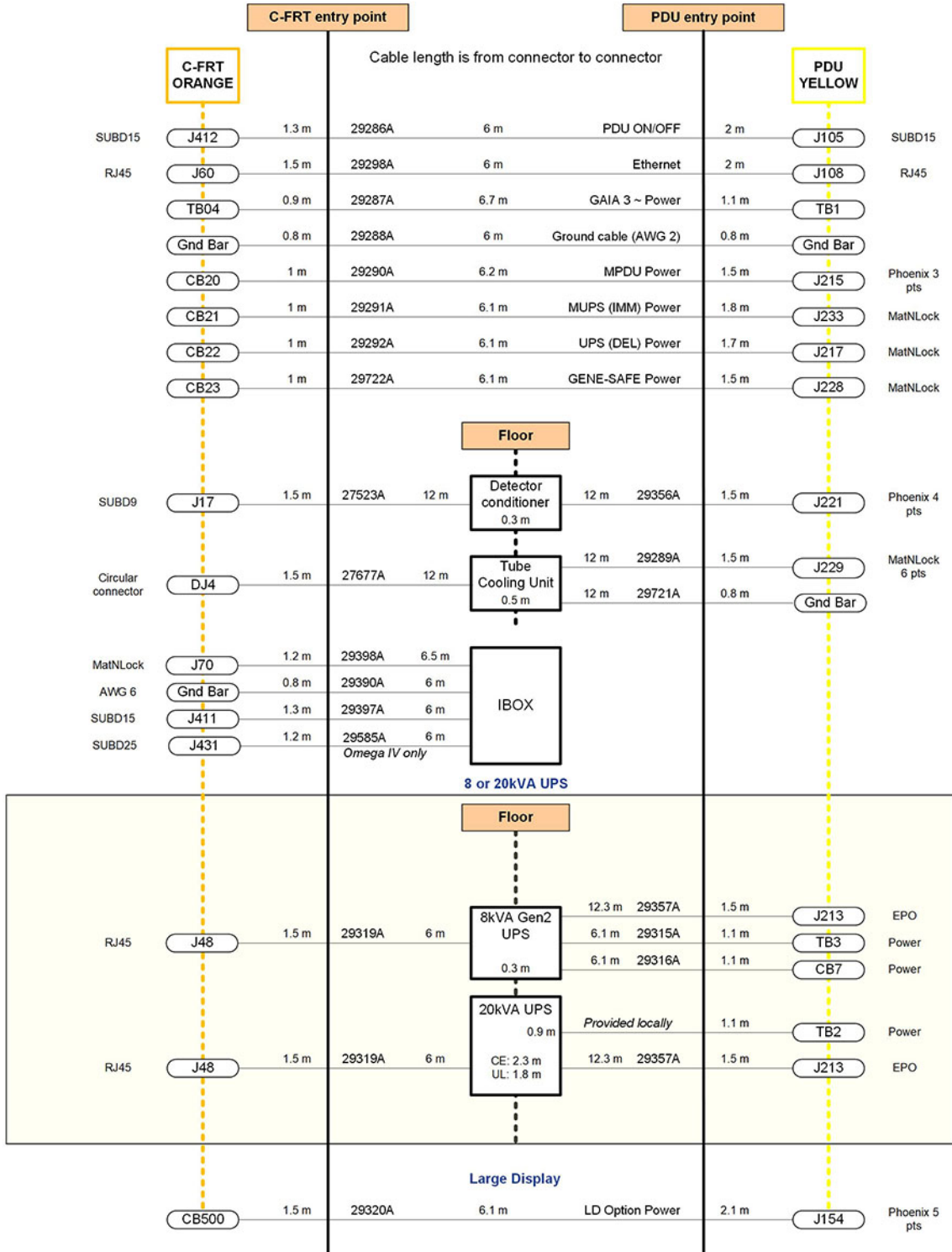


Figure 5-39 (For System with Omega Table) From Technical Room to Technical Room with X-PDU

Technical Room

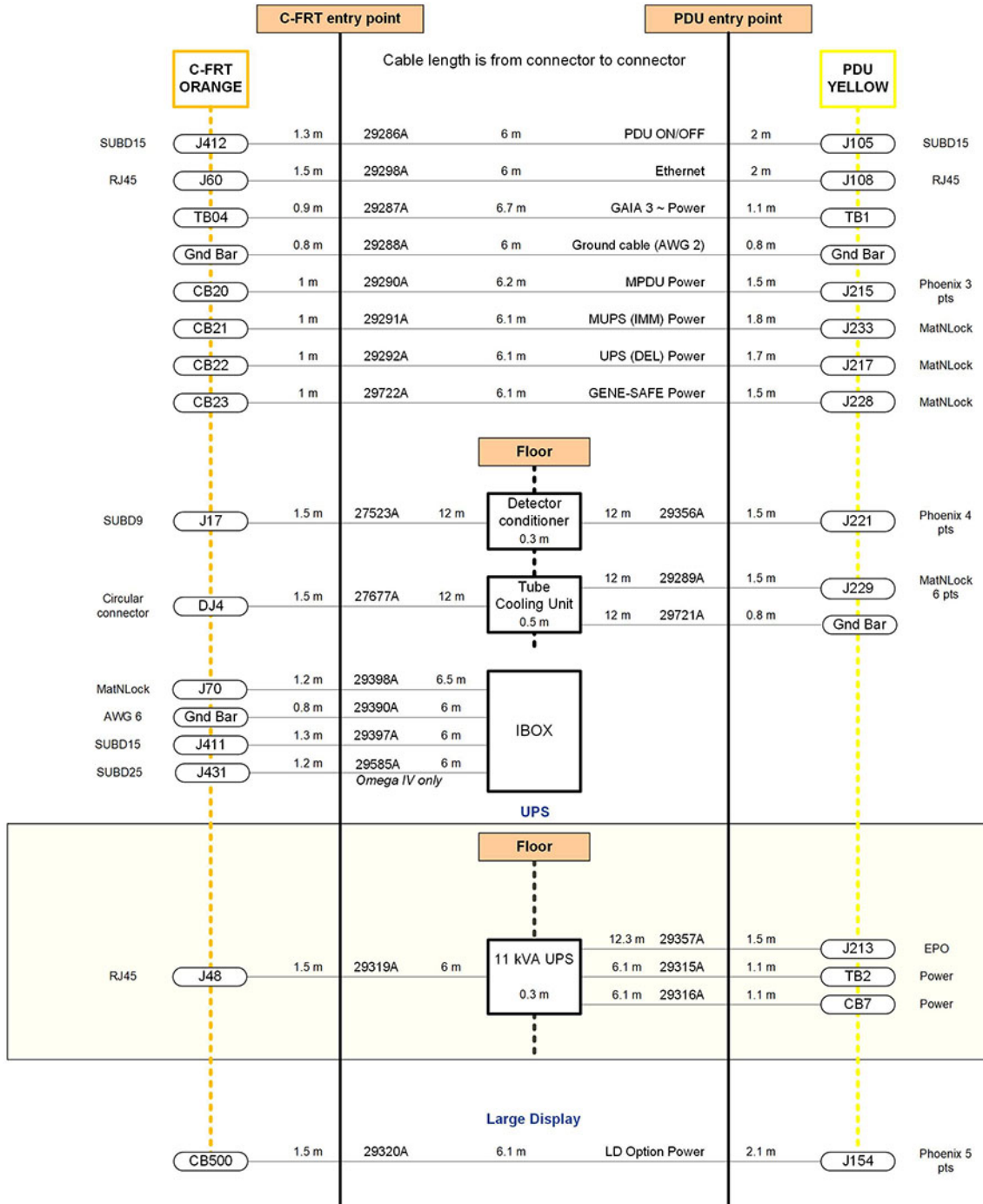
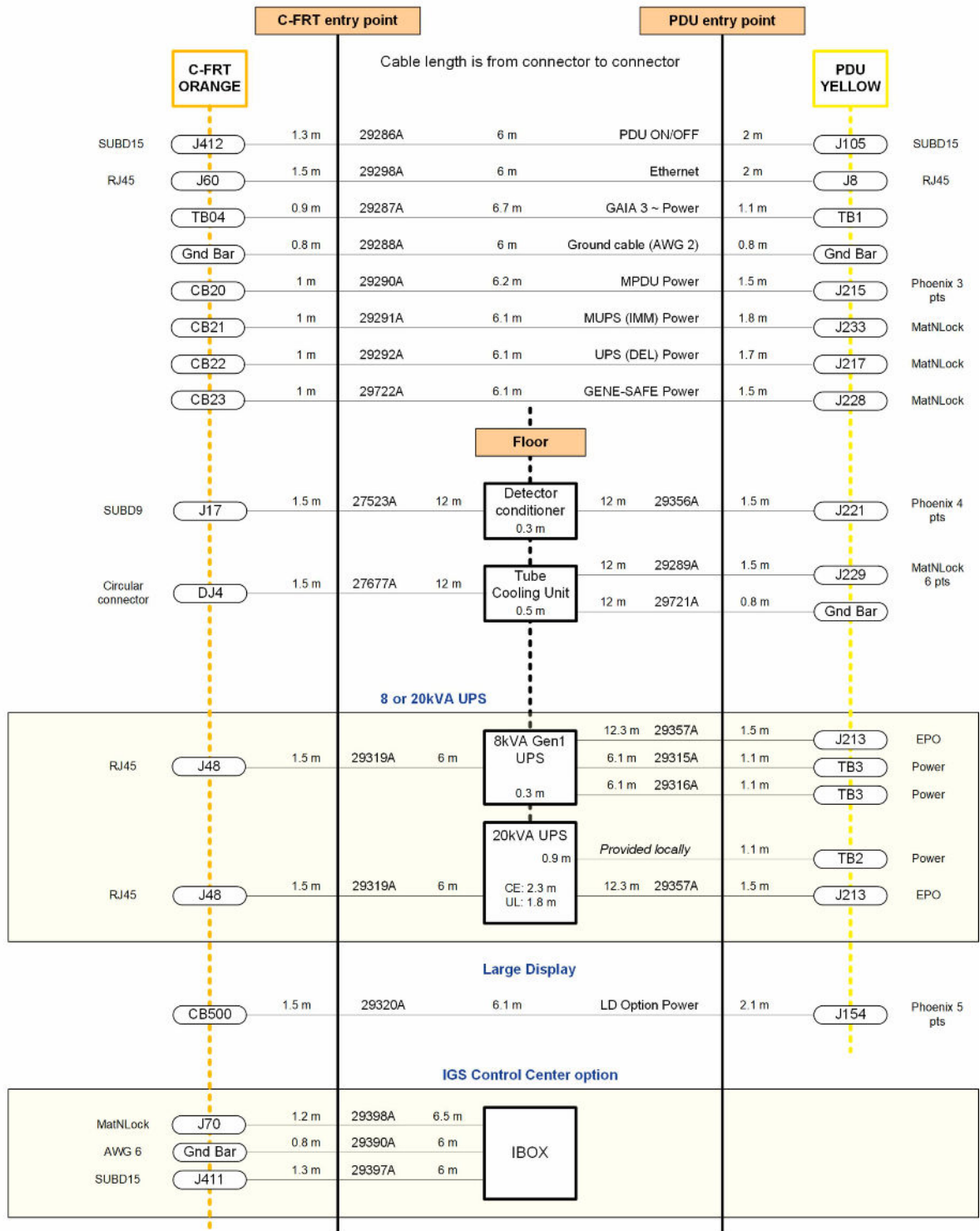


Figure 5-40 (For System with Innova IQ Table) From Technical Room to Technical Room with PDU V2

Technical Room



# Technical Room

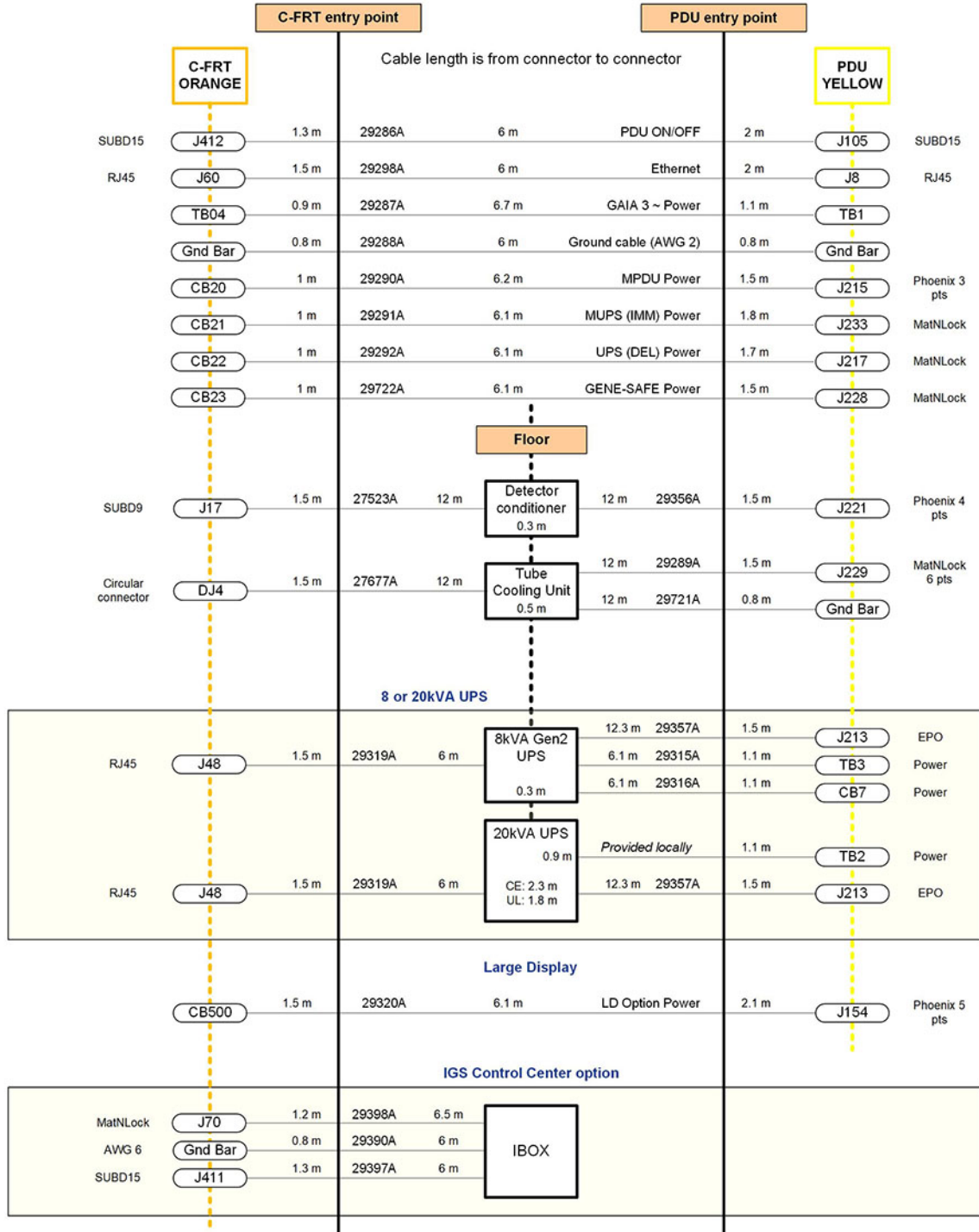


Figure 5-41 (For System with Innova IQ Table) From Technical Room to Technical Room with X-PDU

Technical Room

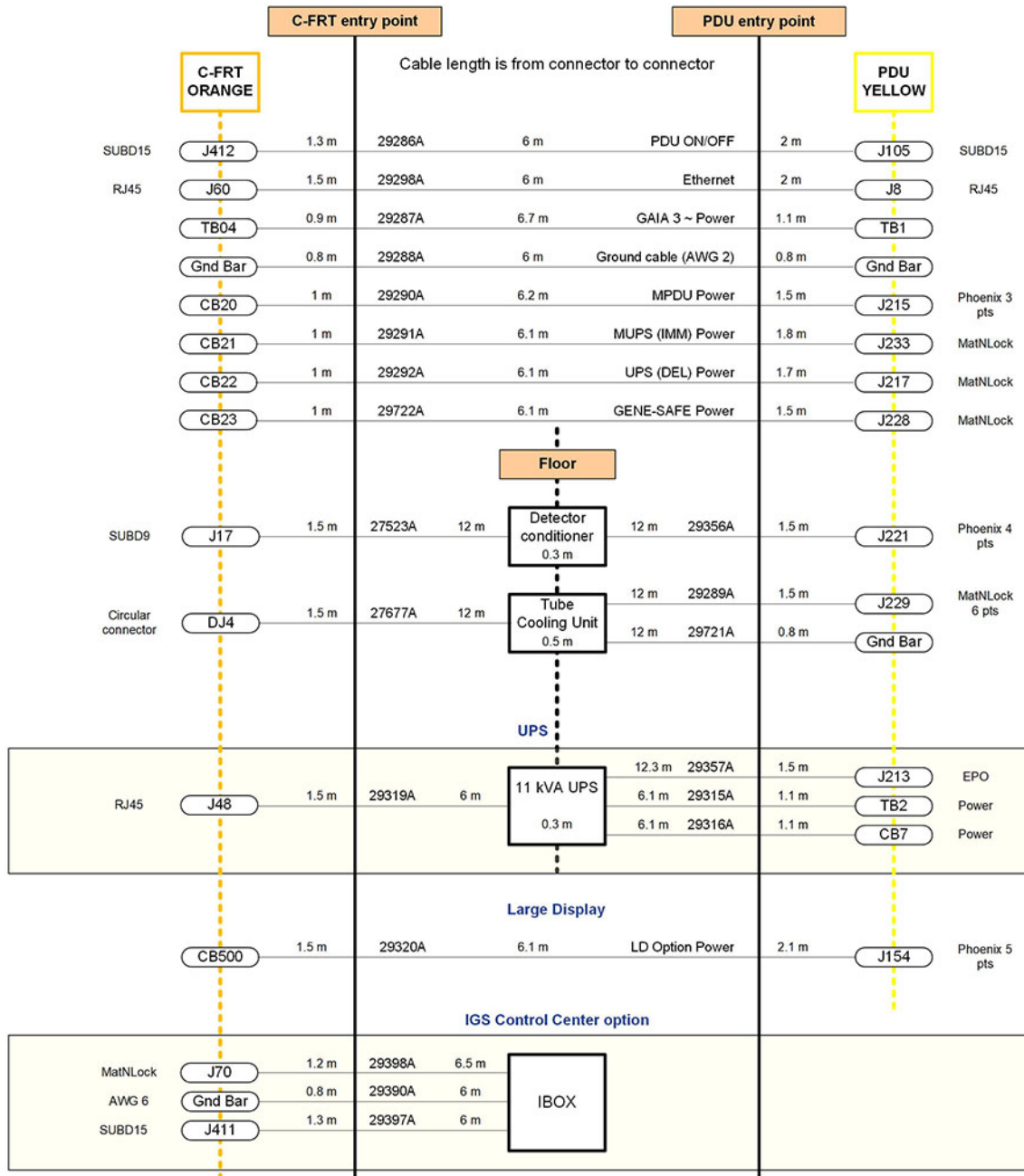


Figure 5-42 From Exam Room to Control Room

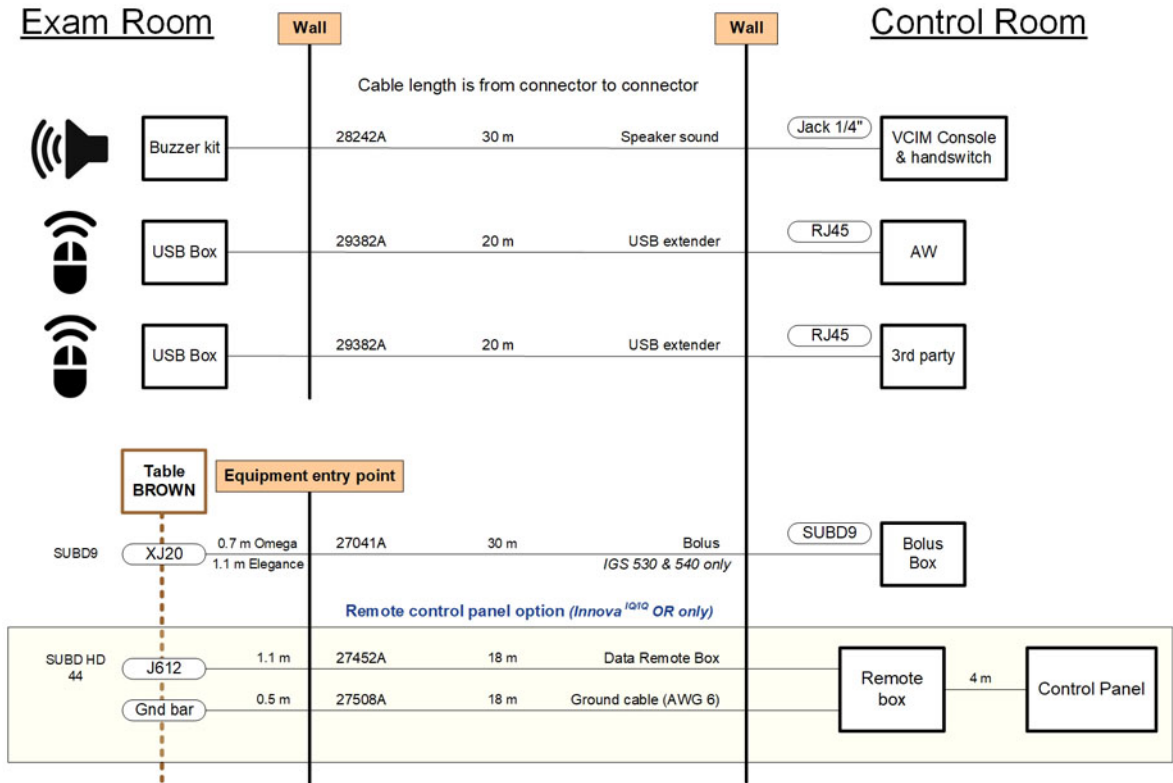
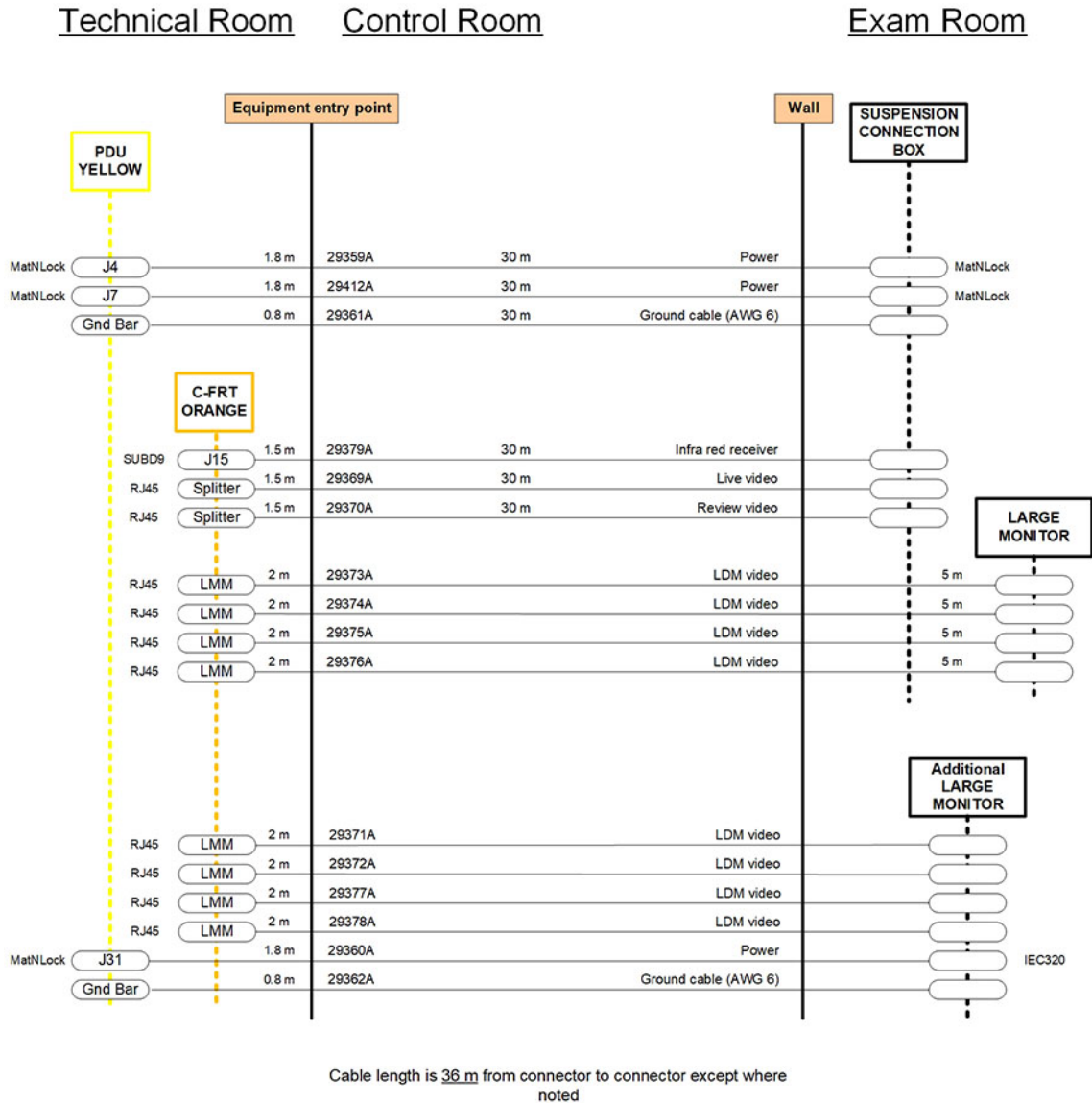


Figure 5-43 LDM suspension



### 5.9.2 MIS (Master Interconnect System)

The system interconnect cables are described in MIS (Master Interconnect System) documents. These documents specify all interconnections between components within the system.

Reference: For specific Vascular system interconnect maps and connection details, refer to the following:

- System MIS Map
- System MIS Charts

#### General Guidelines

The System introduces a new system interconnect with a star distribution for all cables from the technical area. The cables are shipped on spools to create cable groups. Cable group 1 for Exam room and cable group 2 for control room. The cable group shall be put in place during the same action. The cables are routed in the same duct.

The HV cables could be pulled separately.

## 5.9.3 Cable Channeling

### 5.9.3.1 General

High voltage and power cables must be separated from other cables. Use a separate trough in the duct system, or use a separate conduit. Minimize cable length between the MDP and the PDU to reduce voltage regulation problems and wiring costs.

For information about the cables supplied with your system, please refer to [5.9.1 Physical Runs on page 178](#).

### 5.9.3.2 Conduit

Separate conduits must be used for power and signal wires. These wires must be kept separated from each other.

Using conduit imposes some important considerations when used with this system. Of primary concern, the majority of cables used are pre-terminated. Pre-termination greatly simplifies interconnection but makes cable-pulling difficult because of the added dimensions of the connectors.

Conduit must be large enough to pass the cable and connector through with all other cables already in the conduit. Also, the size of conduit chosen must allow for future growth. There is the possibility of additional cables being added later as the system is developed and options are added.

The use of conduit is recommended for cables running overhead between rooms, especially when a diagonal run provides the shortest cable path.

### 5.9.3.3 Electrical Ducts

It's important that electrical ducts have separate compartments for power and signal wires. These wires must be kept separated from each other for proper system operation.

Electrical ducts have advantages, when used with a single room or two adjacent rooms. Electrical ducts combine cabling in a neat and functional appearance, with accessibility and room for expansion.

**NOTE**

Mac-lab cables exit behind the table in the Exam Room.

**NOTE**

For **Fast Link** cable and **Private Link** cable (C-FRT Cabinet - AW station), the static operation bending radius must be at least 4 times the outer cable diameter.

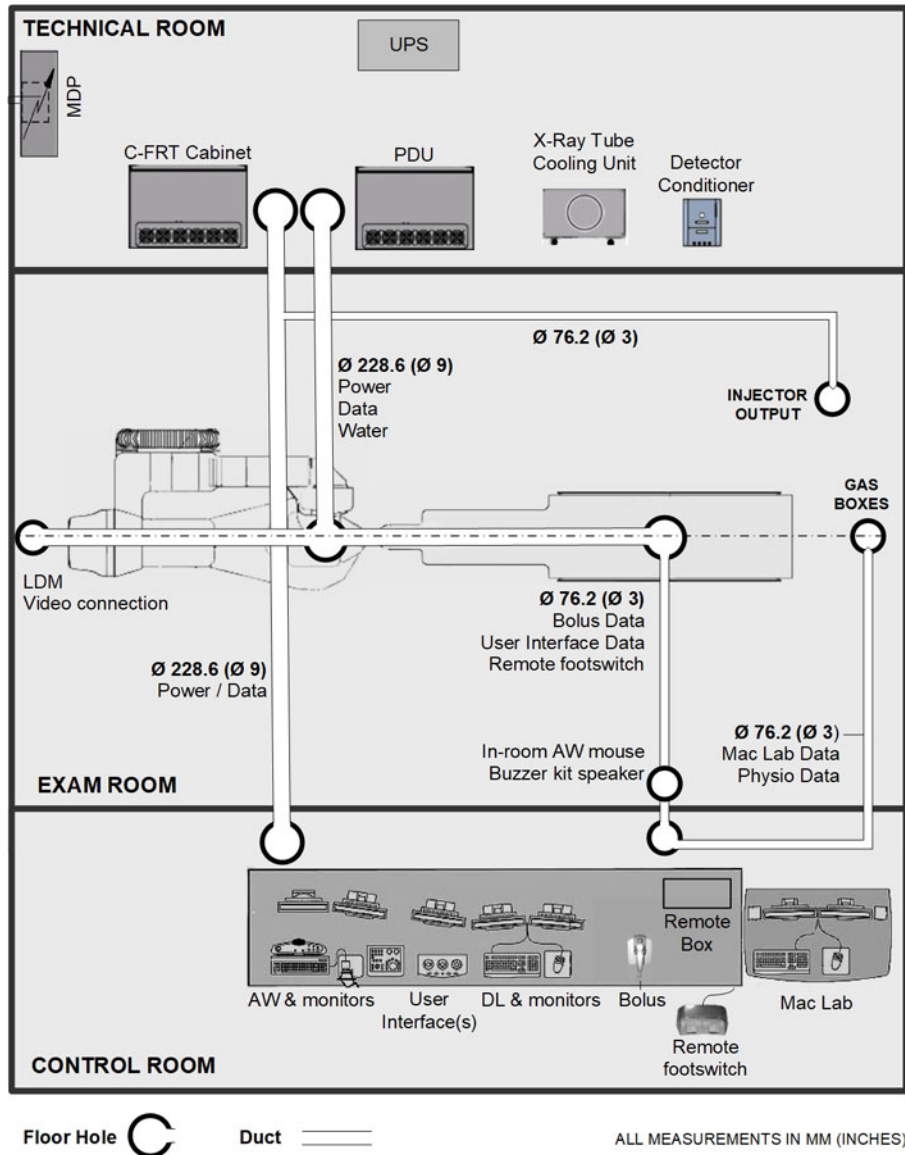
It is the responsibility of the site planner to provide the appropriate solution to the table exit (e.g gas box, Clab II, Tram module, connection interface box).

**NOTE**

Specific Recommendations for installation with GE HealthCare ECG Device such as MacLab, CardioLab or ComboLab:

- TRAM RAC in Exam Room with cable 2016134-106 routed back to Control Room where the other modules & PC are installed
- If no GE HealthCare Maclab cable 2016134-106 installed between the TRAM (Exam Room) and the Control Room, need to route it so that installation/connection of Physio module can be made in Control Room.

Figure 5-44 Cable Channeling Layout



**NOTICE**

In some countries, it is forbidden to run electrical cables and water pipes in the same conduit. In this case, two separate conduits are required.

**NOTICE**

Raceways or cable trays containing electrical conductors shall not contain any pipe, tube or equal for steam, water, air, gas, drainage or any service other than electrical.



**NOTE**

Only the MEDRAD Mark 7 injector with extension cable requires a separate duct.

**NOTE**

The Physio cable can run in the same conduit as the Bolus cable. In this case, it is required to have a conduit between the table and the physio gases box.

If no conduit available between rear of table and Control Room (no Remote User Interfaces, no MacLab...), need to define proper cable routing or create new conduit as per PIM requirements.

If there is no physio gases box behind the table in the lay out, find a local solution to hide the hole in the floor and the cable exit.

## 6 Communication Requirements

### 6.1 Network Requirements

#### 6.1.1 General Information

The system is provided with an internal firewall unit mounted inside the system cabinet and that allows connection to the hospital network for pushing the DICOM images or for service remote access (InSite-RSvP). This firewall is compatible with 10/100/1000 (Gigabit Ethernet) networks.

The C-FRT Cabinet provides an Ethernet RJ45 plug, but the customer is responsible for providing the Ethernet cable between the system and the hospital network.



#### NOTE

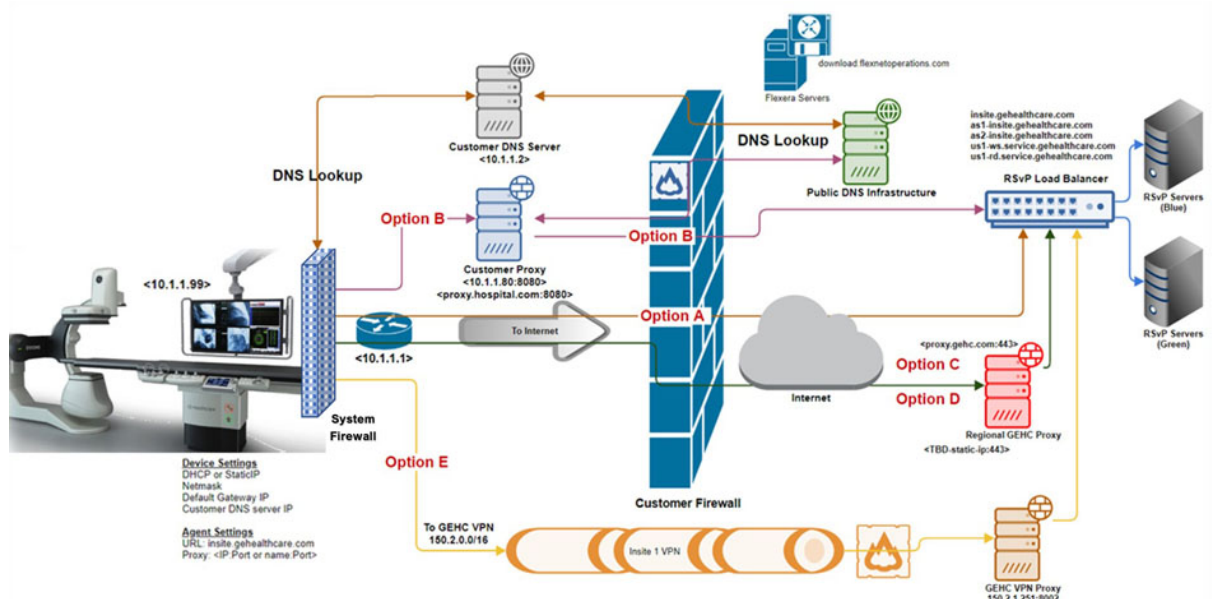
- Connectivity Solutions and pre-installation checklists are available through your local GE HealthCare sales and service representative.
- For InSite-RSvP connections, see information in subsequent sections.

#### 6.1.2 InSite-RSvP Connection Requirements

Service Connectivity for new systems will be based on the InSite-RSvP Platform which allows to configure a direct Internet connection to the RSvP Server (routers/VPN tunnel no more mandatory). Communication with the RSvP server will be outbound only and require using Transport Layer Security (TLS) over TCP port 443. This is commonly known as an HTTPS (HTTP-Secure) connection.

There will be several ways to connect the system to the RSvP Enterprise Server. See below the main options that might not be all available or authorized at your site depending on actual network constraints or local regulations.

**Figure 6-1 Connection to the RSvP Enterprise Server - Example**



**NOTE**

- The system allows for DNS configuration or proxy server-based connection to the Internet (Option A & B).
- Connection thru a GE HealthCare Proxy will be possible in the future (Option C & D).
- In the case the customer does not accept the above connection protocol or regulatory reasons prevent using these types of configurations, the local/regional connectivity teams can provide help to connect through SSL/TLS proxy IP over the site-to-site VPN (Option E).

To make the system connectivity operational before the system installation is finished, ensure the connectivity solution is defined as early as possible during the pre-installation process and proper information are exchanged between the customer Network Administrators and GE HealthCare Sales and/or Service representatives.

For all instructions and support, refer to *RSvP Agent Service Manual*. (This document requires specific access right)

IGS RSvP Quick Guides are available through [https://iresolve.cloud.ge-healthcare.net/vascular\\_wiki/index.php?title=Category:Install](https://iresolve.cloud.ge-healthcare.net/vascular_wiki/index.php?title=Category:Install).

## 6.1.3 Connection Configuration Parameters

Firstly, the IP addresses for DL and AW PCs have to be requested to the Customer Network Administrators at the time of pre-install to not delay the installation along with:

- A IP address of the hospital Gateway.
- A Subnet mask.
- If additional routers and/or static routes are used by the hospital, those must also be provided.

Regarding the Remote Service connection, the following information will be required from the site depending on their preferred solution:

- the Final system ID for the site (final registration in the CRM/FFA)
- a Domain Name System (DNS) server IP addresses
- or a Proxy server IP or Domain Name and Port
- if a customer wants to only whitelist the specific URLs, the following are the required URLs for RSvP connectivity:
  - <https://insite.gehealthcare.com>
  - <https://as1-insite.gehealthcare.com>
  - <https://as2-insite.gehealthcare.com>
  - <https://gehealthcare-ns.flexnetoperations.com>
  - <https://download.flexnetoperations.com>

**NOTE**

- The System PC (DL) and System Firewall module configurations may differ depending on the final connectivity solution chosen.
- If needed, refer to *InSite® RSvP Agent User OR Technical Reference Manual* for details regarding requesting an RSvP connection setup for the customer.

Refer to Section [6.3 Privacy and Security Configuration on page 202](#) to access the complete list of parameters related to the Privacy and Security configurations that may apply to your site and impact network configurations.

**Important Note:**

- To configure and verify the RSvP connection, the following accesses will be required:
    - CRM: Contact the regional field support teams to get access to the correct CRM in the region.
    - FFA: request FFA access through MyAccess <https://gehealthcare.saviyntcloud.com/ECMv6/request/requestHome> after completing the required training.
    - RSvP: Through MyAccess <https://gehealthcare.saviyntcloud.com/ECMv6/request/requestHome>, request RSvP access based on region and modality needed after completing the required training.
- General Support InSite Connectivity Home Page:** [https://insiteplus.cloud.gehealthcare.net/#/case\\_mgmt](https://insiteplus.cloud.gehealthcare.net/#/case_mgmt)
- The Training(s) required for access are listed on the linked support central sites.

## 6.2 DICOM Requirements

The IGS products are DICOM compliant, allowing them to be connected in a network with other DICOM compliant devices for the exchange of images and data.

In some cases, detailed evaluations of the DICOM implementations of devices are needed to ensure interoperability. For this purpose, the DICOM Conformance Statement can be accessed at <https://www.gehealthcare.com/products/interoperability/dicom/xray-mammography-dicom-conformance-statements>, and the IHE Integration Statement can be accessed at <https://www.gehealthcare.com/products/interoperability/ihe/xray-mammography-acquisition-systems-ihe-integration-statements>.

## 6.3 Privacy and Security Configuration

The Privacy and Security features available with the System require to be configured according to the security policy requested by the hospital.

To ensure the installation is successful and is not delayed because of missing information, it is required to gather all needed information as part of the pre-install process.

The typical parameters are the one listed below. The complete list is provided in Tab "Security Configuration" of the document *IGS System Installation Prerequisites - DOC2024755*. See also Important Notice below.

- **Machine Account**
- **User Authentication**
- **Authorization**
- **Audit Trail**
- **Malware protection**
- **Network Security**
- **Data Transmission and Protection**
- **Other Requirements**

**NOTICE**

Always refer to the detailed Checklist provided in the document *IGS System Installation Prerequisites - DOC2024755* available from the Customer Documentation Portal. Always use the last revision which will contain all mandatory updates.

Support on Privacy and Security can also be found here: <https://www.gehealthcare.com/productsecurity/products>.



[www.gehealthcare.com](http://www.gehealthcare.com)